

BELLA

Version: 02 - 22072010

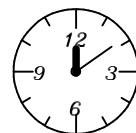

50 min

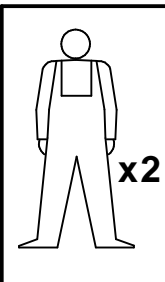
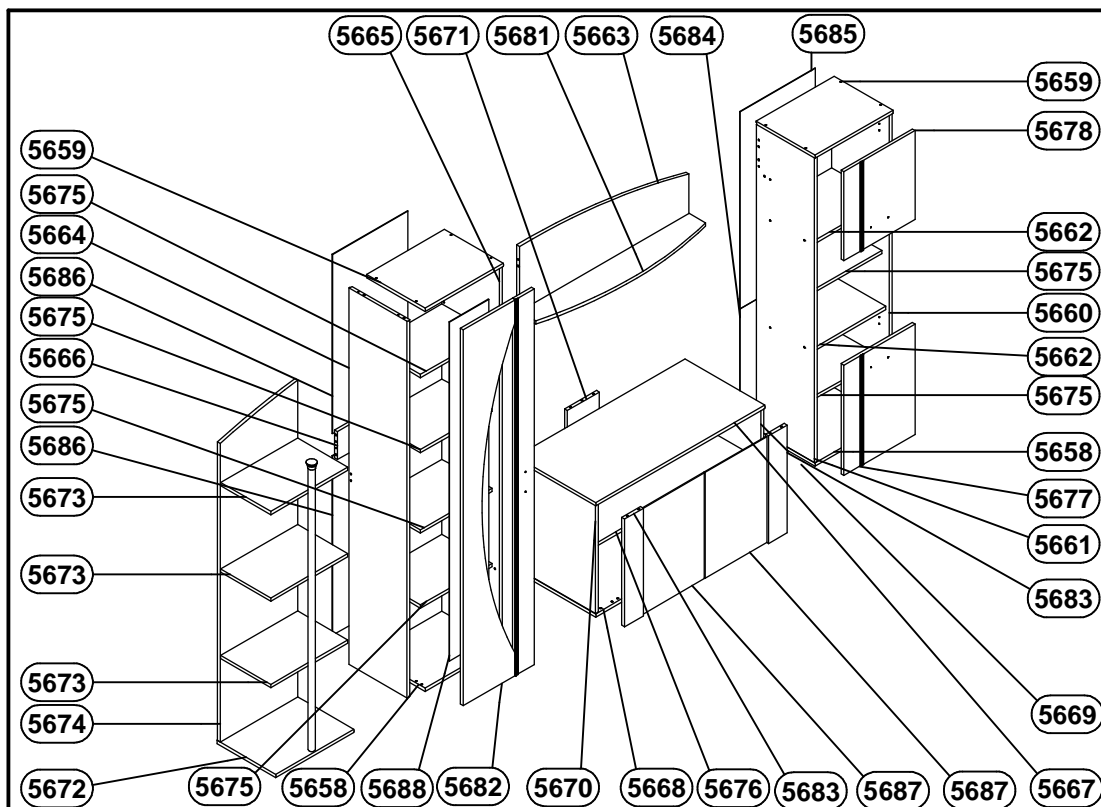
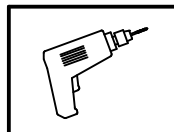
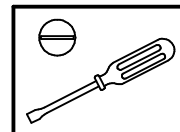
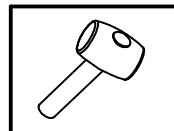
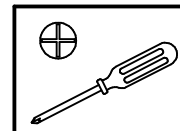

PRE POČETKA MONTIRANJA OBAVEZNO
 PROČITAJTE UPUTSTVO ZA MONTAŽU
 BEFORE STARTING, REFER TO THE ASSEMBLING
 ADVICE IN ANNEX
 VOR DIE MONTAGE, BITTE BEILIEGENDE
 ANWEISUNGEN FOLGEN
 AVANT DE COMMENCER, SE REPORTER AUX
 CONSEILS DE MONTAGE EN ANNEXE
 ANTES DE EMPEZAR EL MONTAJE LEAN
 OBLIGATORIAMENTE LAS INSTRUCCIONES
 DE MONTAJE
 AVANTI DI COMMINCIARE, RIPORTATE AGLI
 CONSIGLI DI MONTAGGIO
 IMA DI INIZIARE L'INSTALLAZIONE SI
 RACCOMANDA LEGGERE LE ISTRUZIONI
 ДО НАЧАЛА МОНТАЖА ОЗНАКОМЬТЕСЬ
 С ИНСТРУКЦИЕЙ
 SEZNÁMÍTE SE S NÁVODEM PRED MONTAŽI
 NÁBYTKU
 ΠΡΙΝ ΑΠΟ ΤΗΝ ΑΡΧΗ ΠΡΕΠΕΙ ΝΑ ΔΙΑΒΑΣΕΤΕ
 ΟΙ ΟΔΗΓΙΕΣ ΧΡΗΣΕΩΝ
 ÎNAINTE DE ÎNCEPEREA MONTAJULUI ESTE
 OBLIGATORIE CITIREA INSTRUCȚIUNILOR
 ПРЕДИ МОНТИРАНЕ НЕ ЗАБРАВЯЙТЕ ДА СК
 ЧЕТЕ ИНСТРУКЦИИ ЗА МОНТАЖ
 PRED ZAČETKOM MONTAŽE OBVEZNO
 PREBERITE NAVODILA
 ÖSSZEÁLLÍTÁS ELŐTT ÖKVELTEN OLVASSA EL
 A HASZNÁLATI UTASÍTÁST
 ПРЕД ПОЧЕТОК НА МОНТИРАЊЕ ЗАДОЛЖИТЕЛНО
 ДА СЕ ПРОЧИТА УПАТСТВОТО ЗА МОНТИРАЊЕ
 PRIJE MONTAŽE UPOZNATI SE SA UPUTSTVOM
 PARA RRIITJE TË SIGURT QË JU LEXONI
 UDĚZIMET PĚR INSTALLATION

A ∅8x30 x62	B x48	C x8	D x8	E x24	F x8	G x3	H M4x25 x6	I x29	J x2
K x18	L x1	M x2	N 1400mm x1	O x1	P x1	Q x17	R 3x16 x24	S 4x16 x6	T 3x25 x2
U 5x50 x1	V x2	W x1	X 10x60 x1	Y x2	Z x7	Aa x7	Ab 431mm + 535mm x(1 + 1)	Ac 1825mm x1	Ad 1.6x25 x54

(SRB) (MNE)

1. Montažu obavljati na čistoj i mekoj podlozi (karton, tkanina...)
2. Da bi izbegli oštećenja elemenata pridržavati se datih instrukcija.
3. Prilikom prijave reklamacije koristiti date oznake elemenata.

(DE) (AUS) (CH)

1. Montage soll auf der sauberen, weichen Fläche durchgeführt werden (Karton, Stoff)
2. Um die Beschädigung der Teile zu vermeiden, folgen Sie bitte den Instruktionen
3. Bei der Anmeldung der Reklamation benutzen Sie bitte angegebene Kennzeichen der Teile

(ESP)

1. Efectuar el montaje sobre un fundamento limpio y blando (carton, tejido).
2. Para evitar daños a los elementos atenerse a las instrucciones dadas
3. En ocasión de presentar una reclamación utilizar las señas dadas de los elementos.

(RUS) (BLR)

1. Монтаж изделия выполнять на чистой и мягкой поверхности (картон, ткань)
2. Для предотвращения порчи изделий необходимо придерживаться правил монтажа
3. При сообщении о наличии бракованных изделий необходимо руководствоваться обозначениями из инструкции

(SLO)

1. Montažo opravimo na čisti in mehki podlogi (karton, tkanina)
2. Da bi se ozognili poškodbam elementov, upoštevajte navodila.
3. Pri reklamaciji uporabimo oznake elementov

(ROU)

1. Montarea se efectueaza pe o suprafata moale si curata (carton, material..)
2. Respectati instructiunile pentru a evita deteriorarea pieselor
3. La transmiterea reclamatilor a se folosi insemnele pieselor

(BGR)

1. Монтажа да бъде извършен на чиста и мека повърхност /картон, плат/
2. За да избегнете нараняване на елементите придържайте се към дадените инструкции
3. При наличие на рекламация използвайте дадените означения на елементите

(MKD)

1. Монтажа да се врши на чиста и мека подлога (картон, тканина)
2. За да се избегне оштетување на елементите придржувајте се на дадените инструкции
3. За пријава на рекламација користете ги дадените ознаки на елементите

(ENG)

1. Assembly of the product should be done on a clean and soft surface (cardboard, fabric)
2. To prevent damage of the product, it is necessary to adhere to the assembly instructions
3. While reporting defective products, please quote codes in manual

(FRA) (CH)

1. Aménagez-vous une surface de montage propre pour éviter tout dommage sur les meubles. Une couverture les protègera des rayures.
2. Veuillez suivre scrupuleusement les instructions de montage afin de ne pas endommager les meubles.
3. Conservez votre notice de montage, si une pièce venait à manquer elle serait le moyen le plus claire de communiquer avec votre revendeur.

(ITA) (CH)

1. Fare l'installazione su una base morbida (cartone, tessuto)
2. Seguire le istruzioni per evitare di danneggiare gli elementi
3. Per reclamare usare relative indicazioni degli elementi

(CZ) (SK)

1. Montáž provádět na čisté a měkké podlaze (lepenka, látka)
2. Dodržujte přiložené instrukce, abyste předešli poškození součástí
3. Při reklamaci používejte přiložené označení elementů

(GR)

1. Η συνέλευση του προϊόντος πρέπει να γίνει σε μια καθαρή και μαλακή επιφάνεια (χαρτόνι, ύφασμα)
2. Θελήστε να ακολουθήσει σχολαστικά τις οδηγίες της συνέλευσης για να μη να βλάψει τα έπιπλα.
3. Εκθέτοντας τα ελαττωματικά προϊόντα, παρακαλώ αναφέρετε τους κώδικες στο εγχειρίδιο

(CRO) (BiH)

1. Montažu obavljati na čistoj i mekoj podlozi (karton, tkanina)
2. Da bi izbegli oštećenja elemenata pridržavati se datih instrukcija
3. Prilikom prijave reklamacije koristiti date oznake elemenata

(HU)

1. ÖSSZESZERELÉST TESÉK VÉGREHAJATANI TISZTA ES PUHA FELÜLETEN (KARTON, ANYAG).
2. KÁROSODÁSNAK ELKERÜLÉSE ÉRDEKÉBEN, TARTÓZKODJON A MEGADOTT UTASÍTÁSOKHOZ.
3. REKLAMÁCIO ESETÉN IGÉNYBE KELL VENNİ A MEGADOTT JELEKET A BUTOR ALKATRÉSZEIN.

(ALB)

1. Montimi të bëhet në sipërfaqe të pastër dhe të butë (karton ,tekstil)
2. Që t'u shmangemi dëmtimit të elementeve , përmbahuni instrukcioneve të dhëna
3. Me rastin e reklamimit përdorni shenjat e dhëna të elementeve

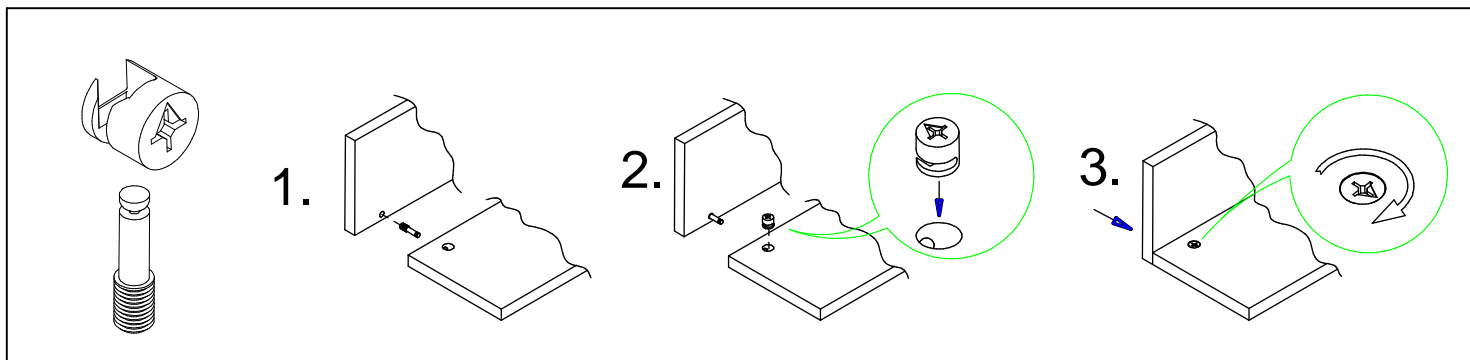
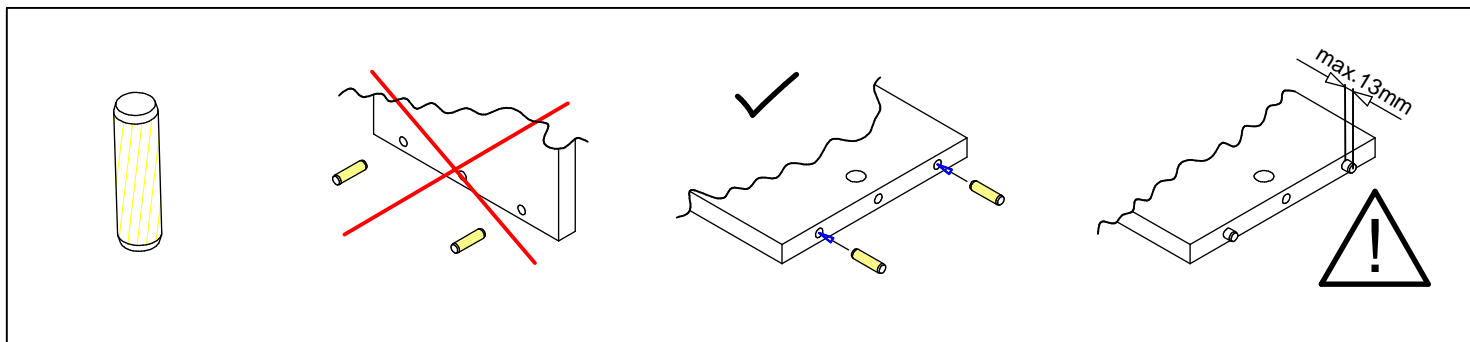

1

Ax4

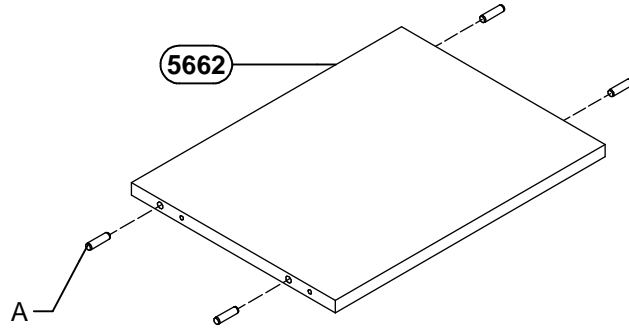

x 2

2

Ax4



lx4

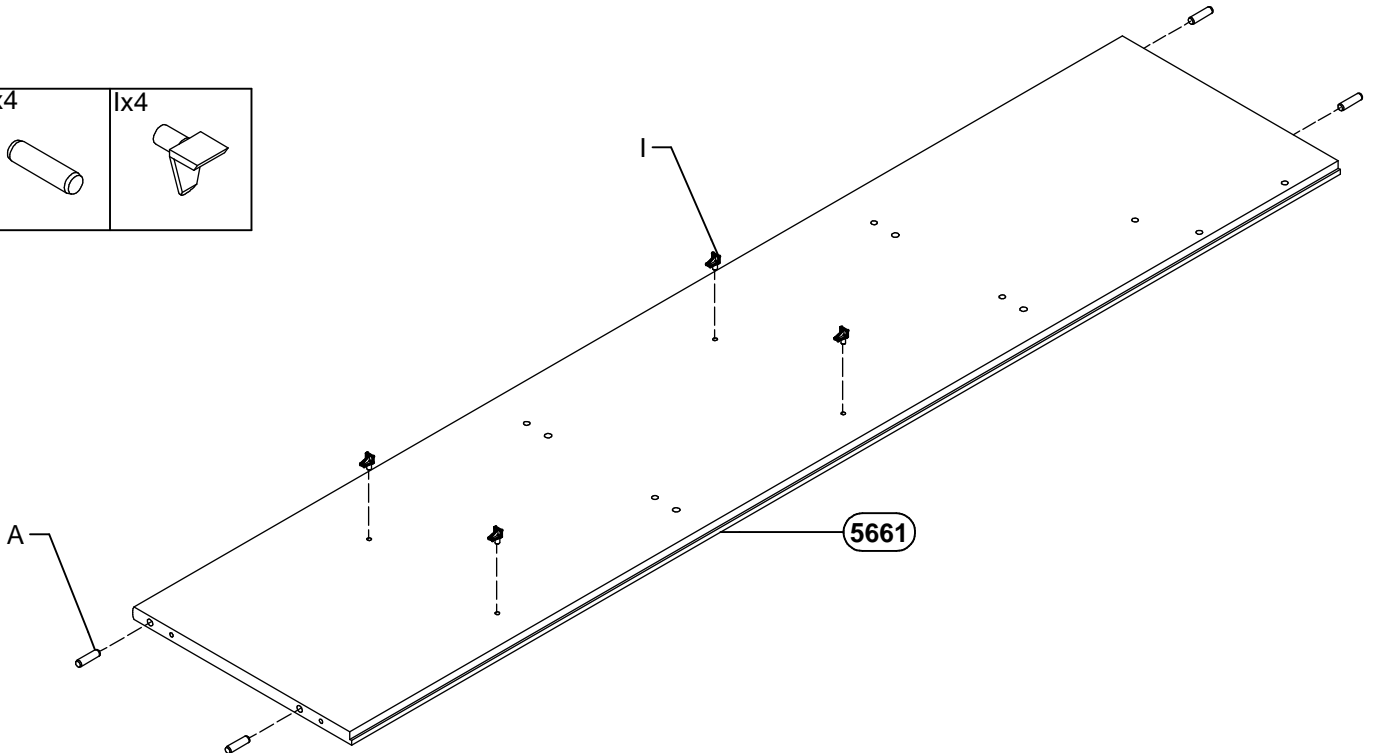

3

Ax4





lx4

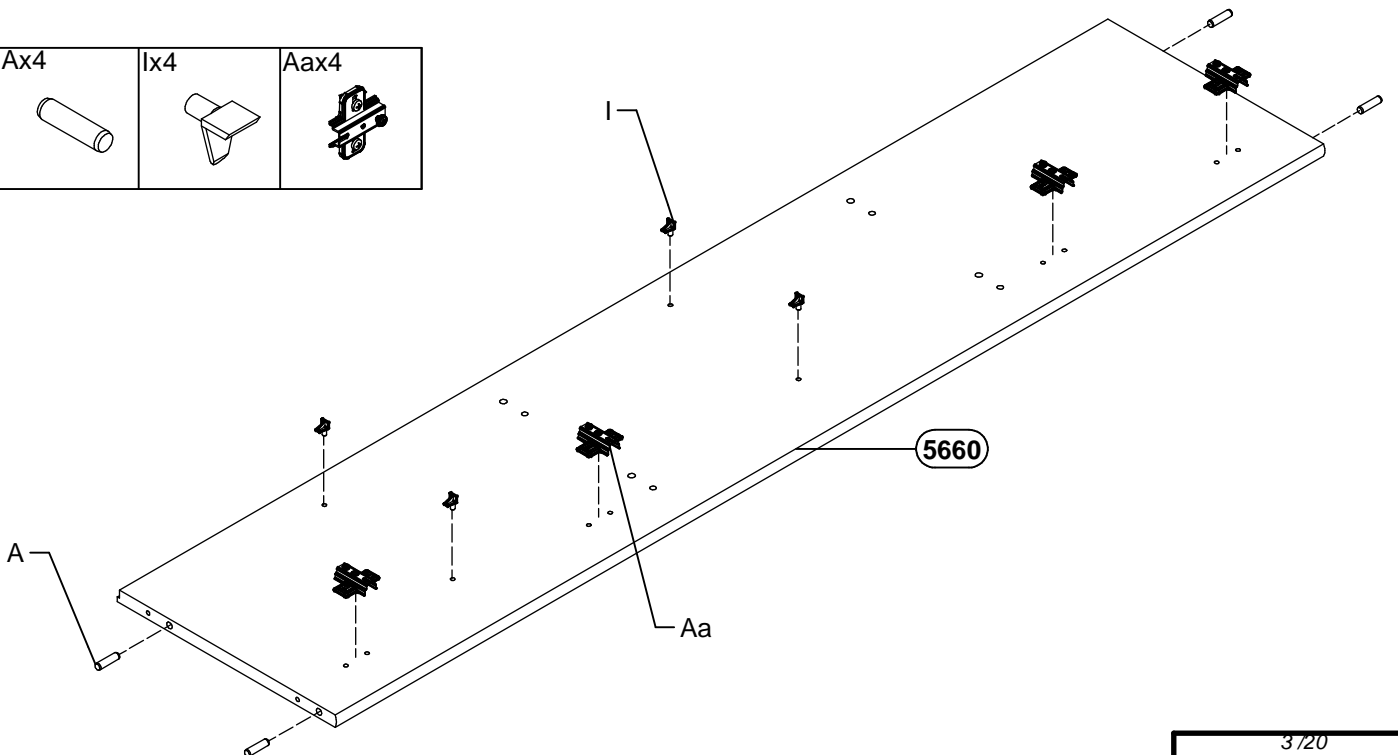

Aax4



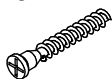

4

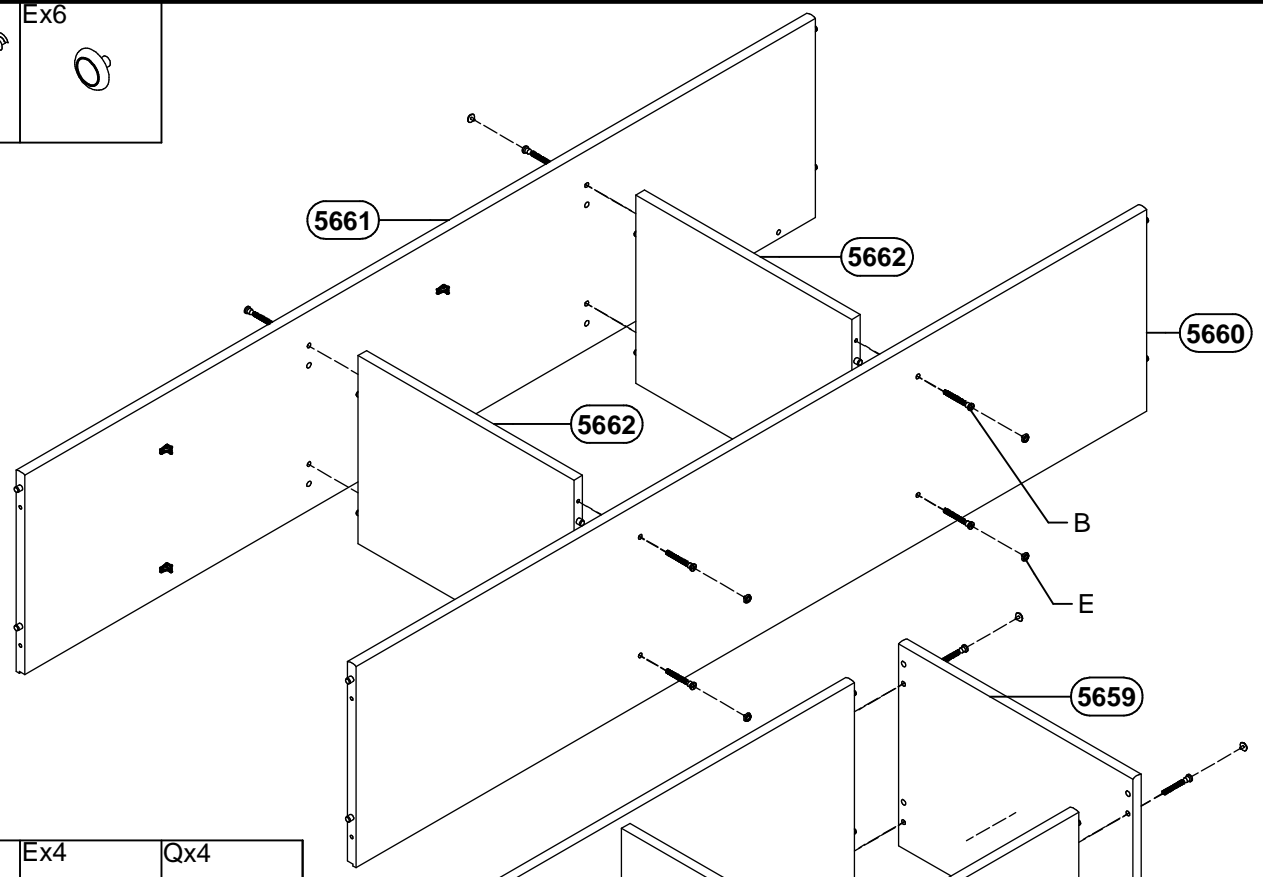
Bx8	Ex6
	

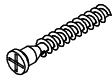

5

Bx8	Ex4	Qx4
		

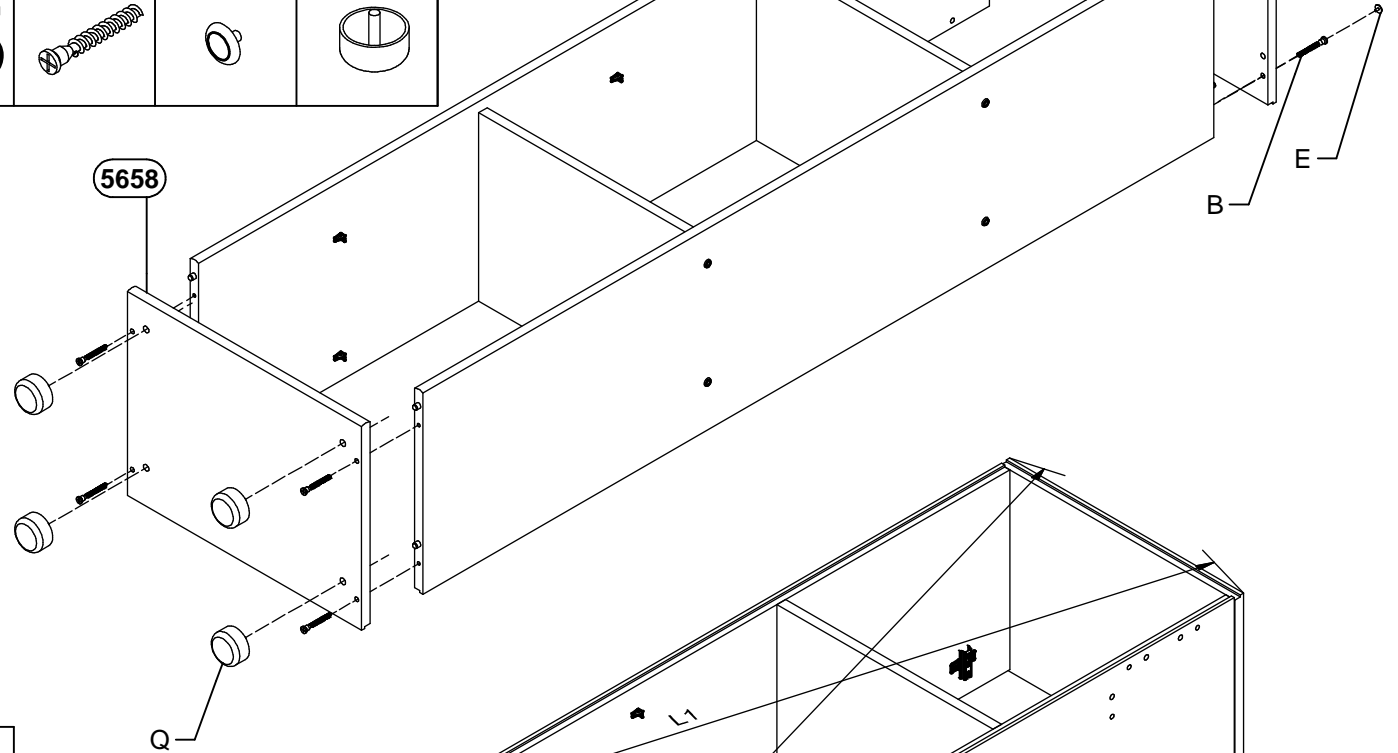

6

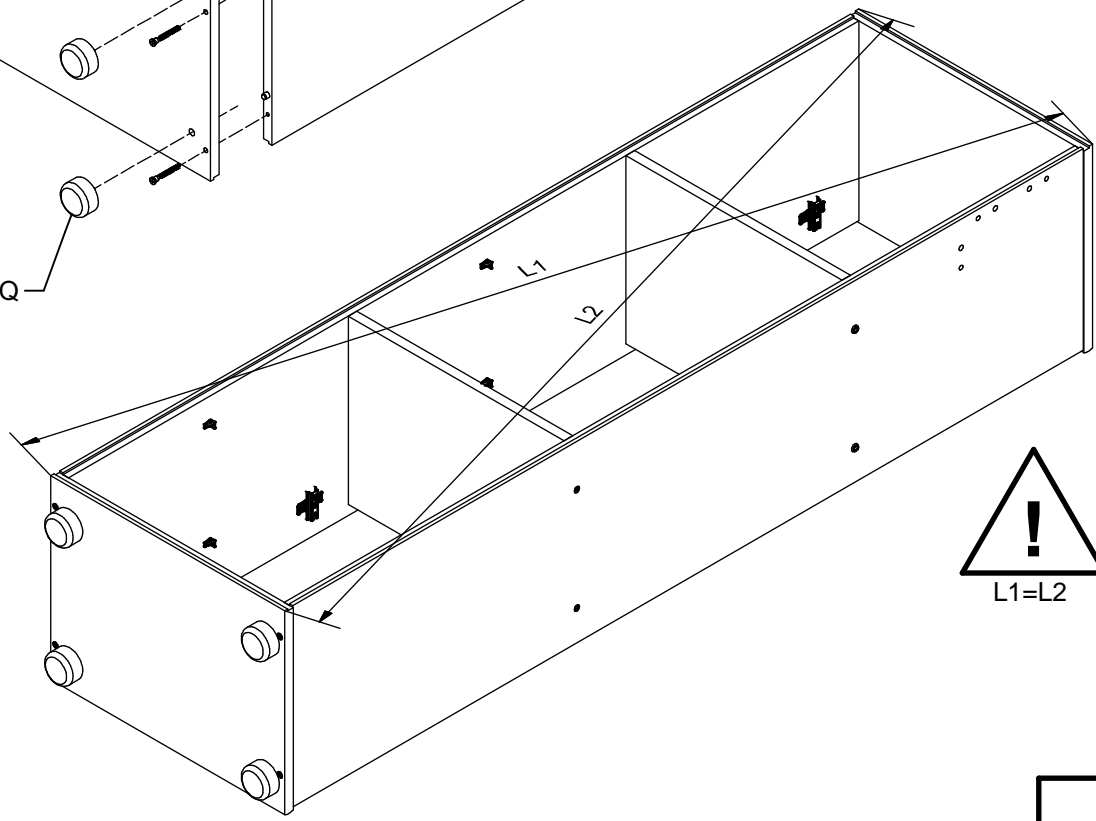

7

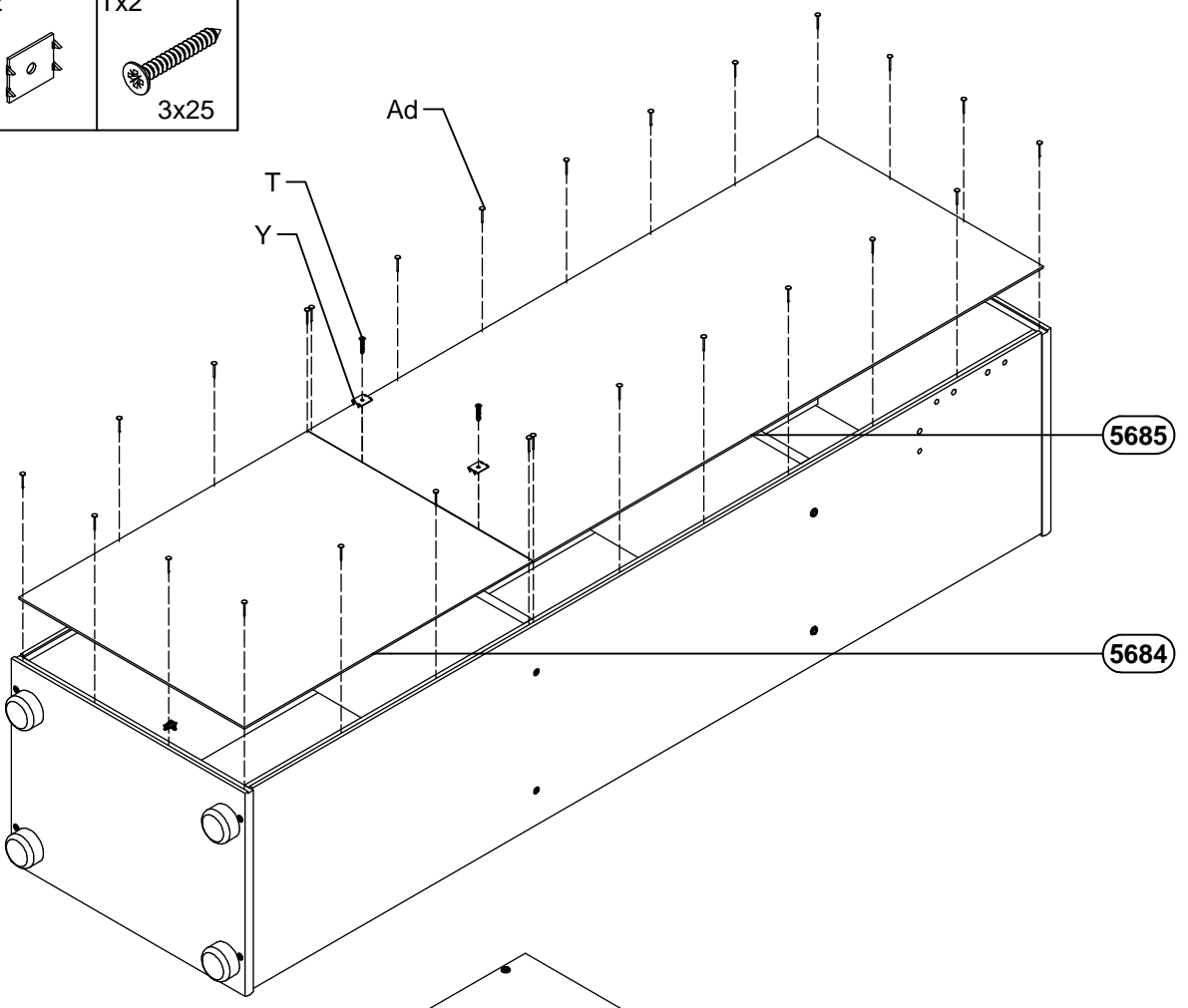
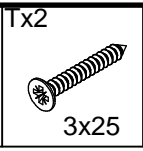
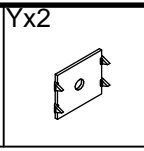
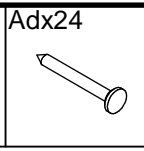

8

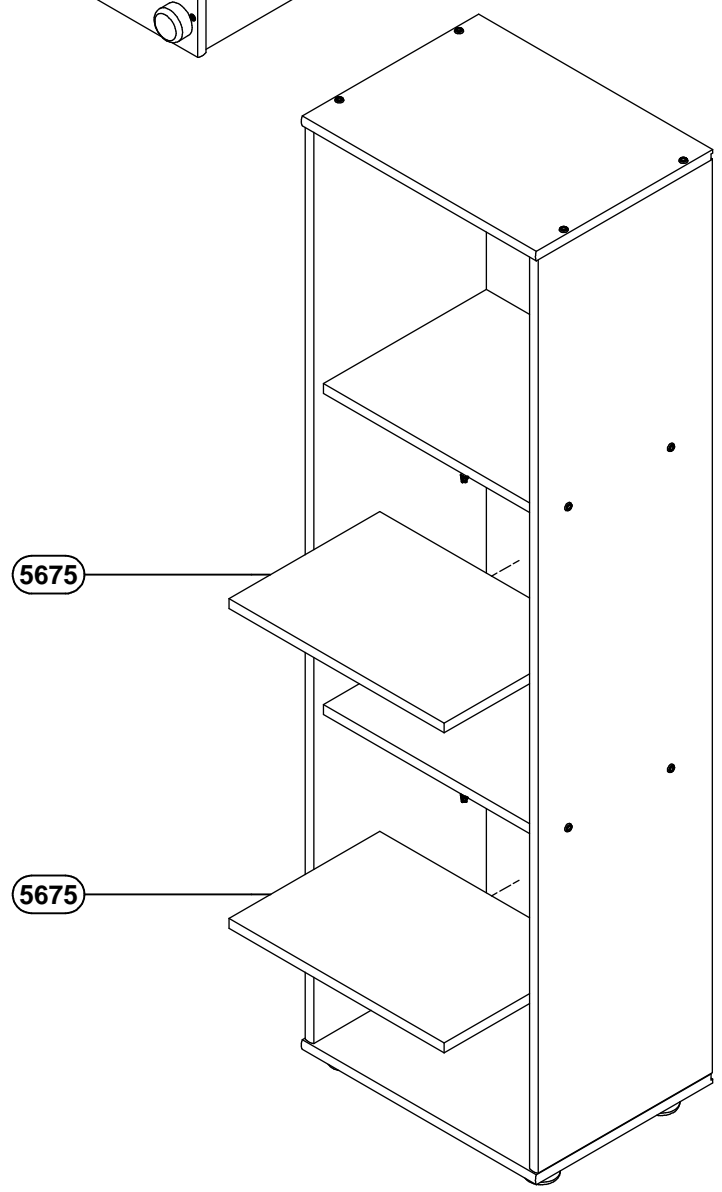

9 Ax4 lx2 Dx2

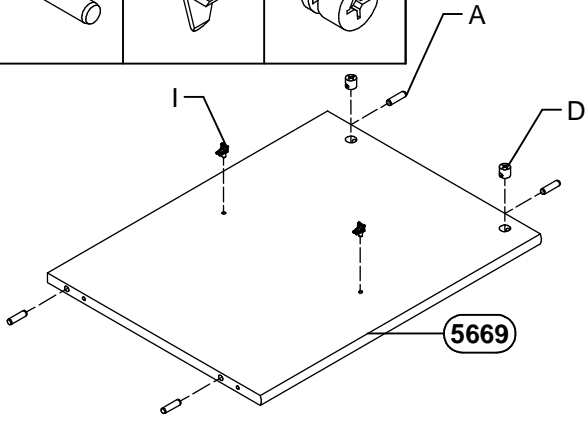

10 Ax4 lx2 Dx2

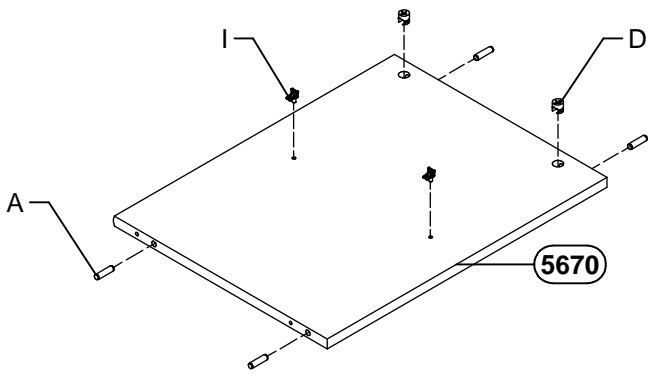

11 Ax4

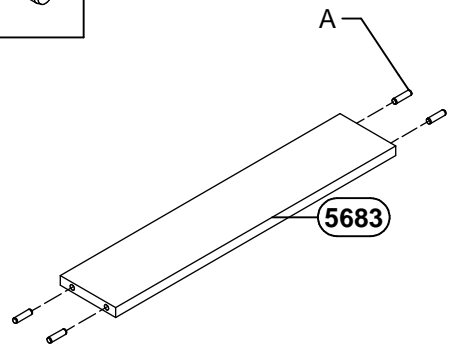

12 Ax4 lx1 Dx1

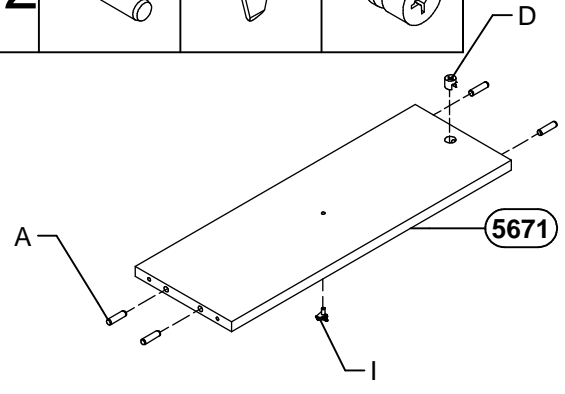

13 Mx2

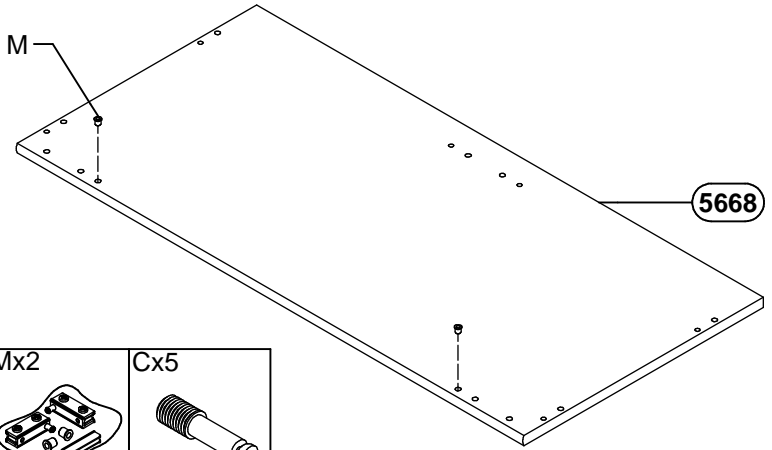

14 Lx1 Rx2 Mx2 Cx5

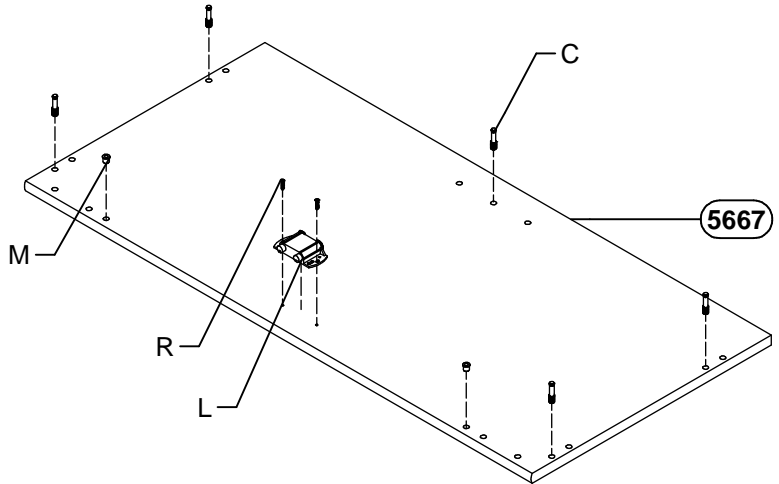

15

Bx6

Qx5

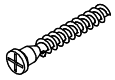

5668

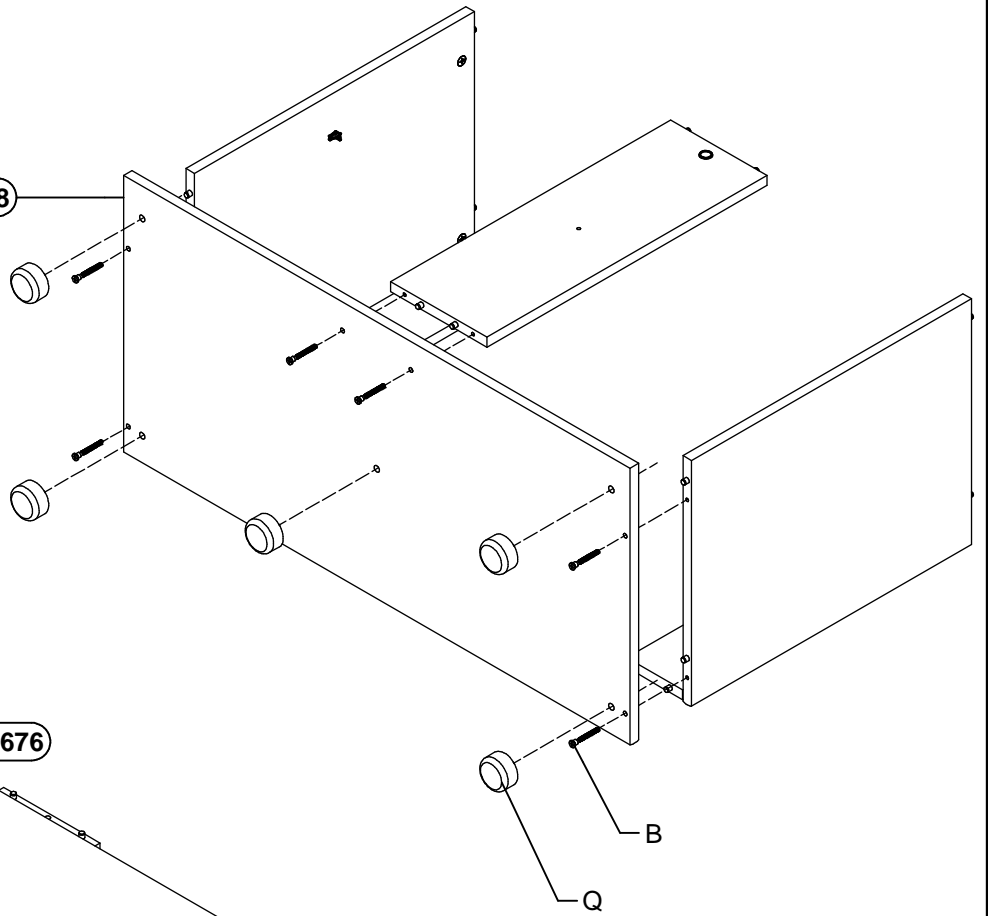

16

5676

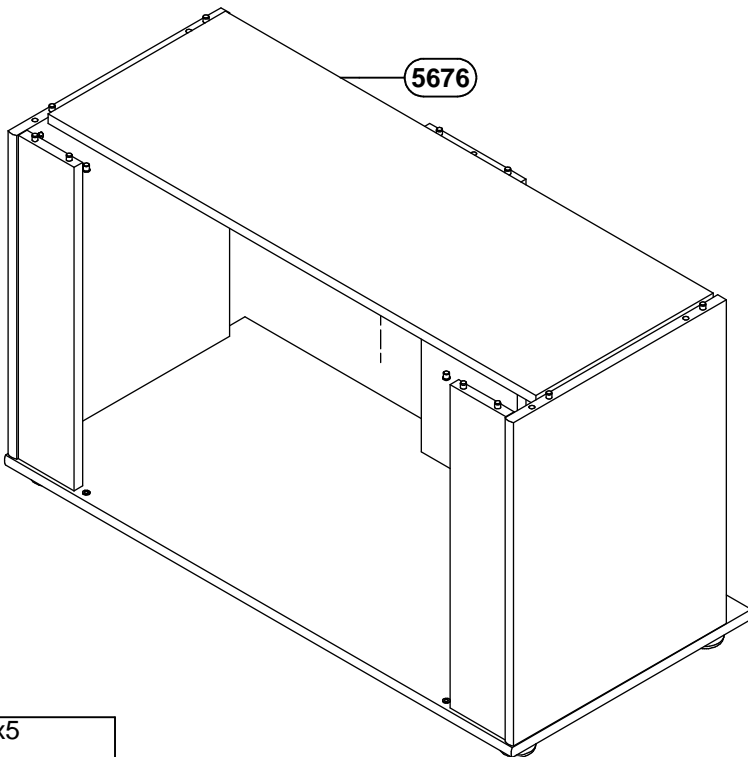

17

Fx5



5667

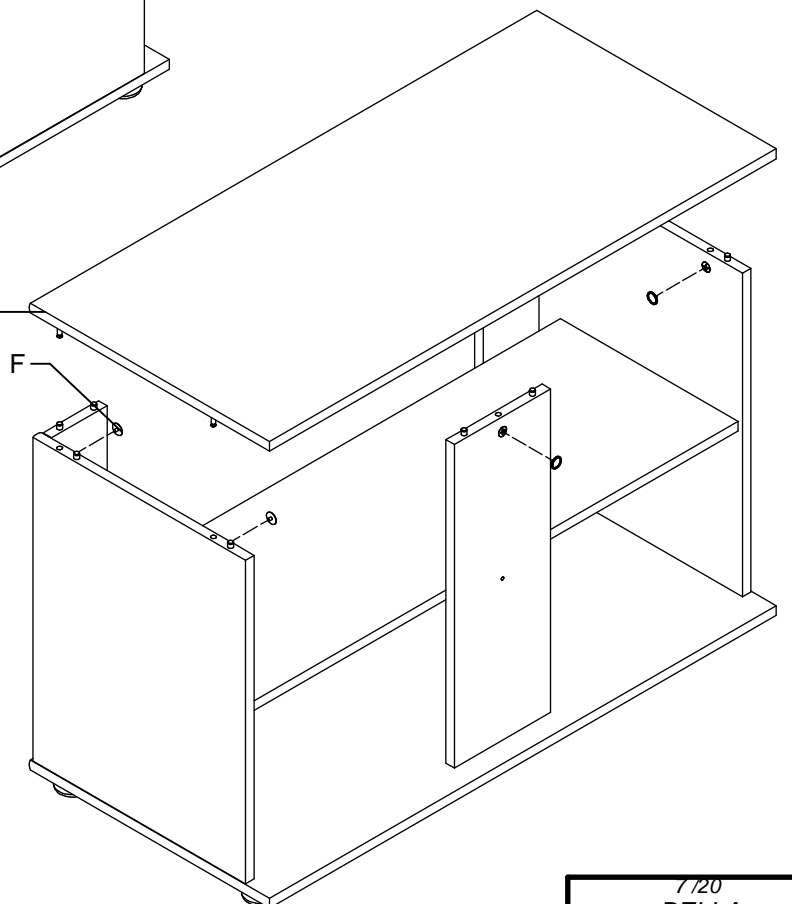

18

Mx2

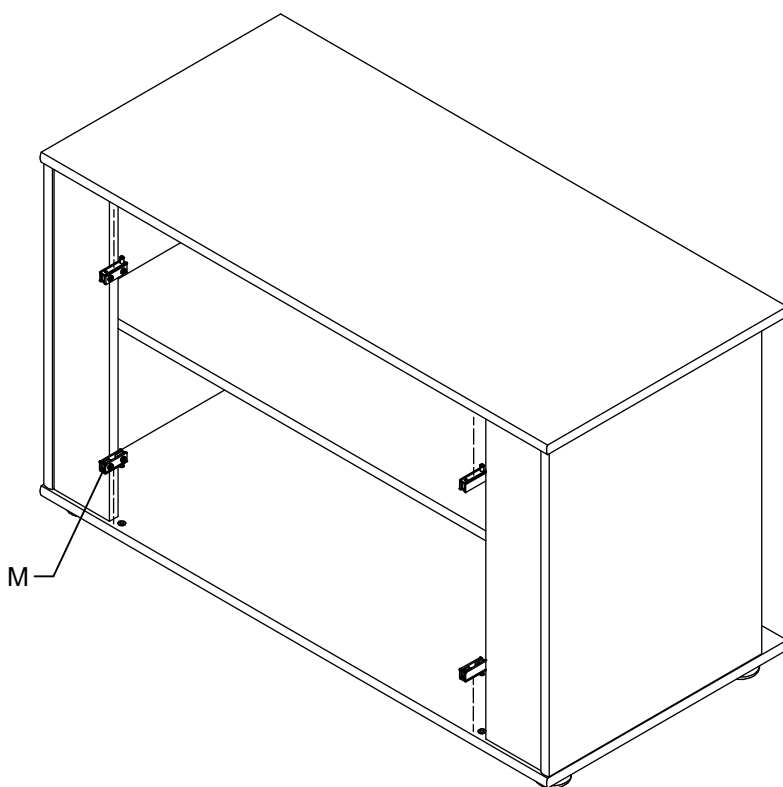
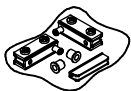

19

Mx2

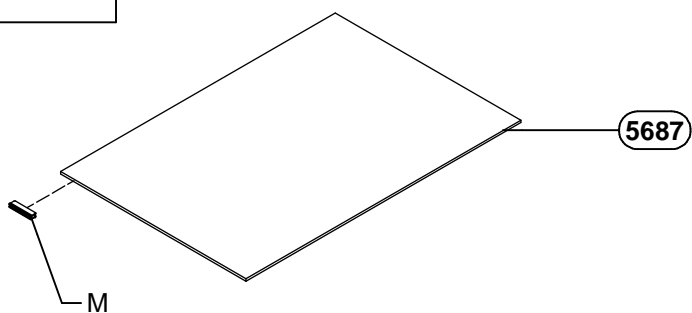
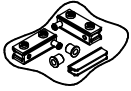

x 2

20

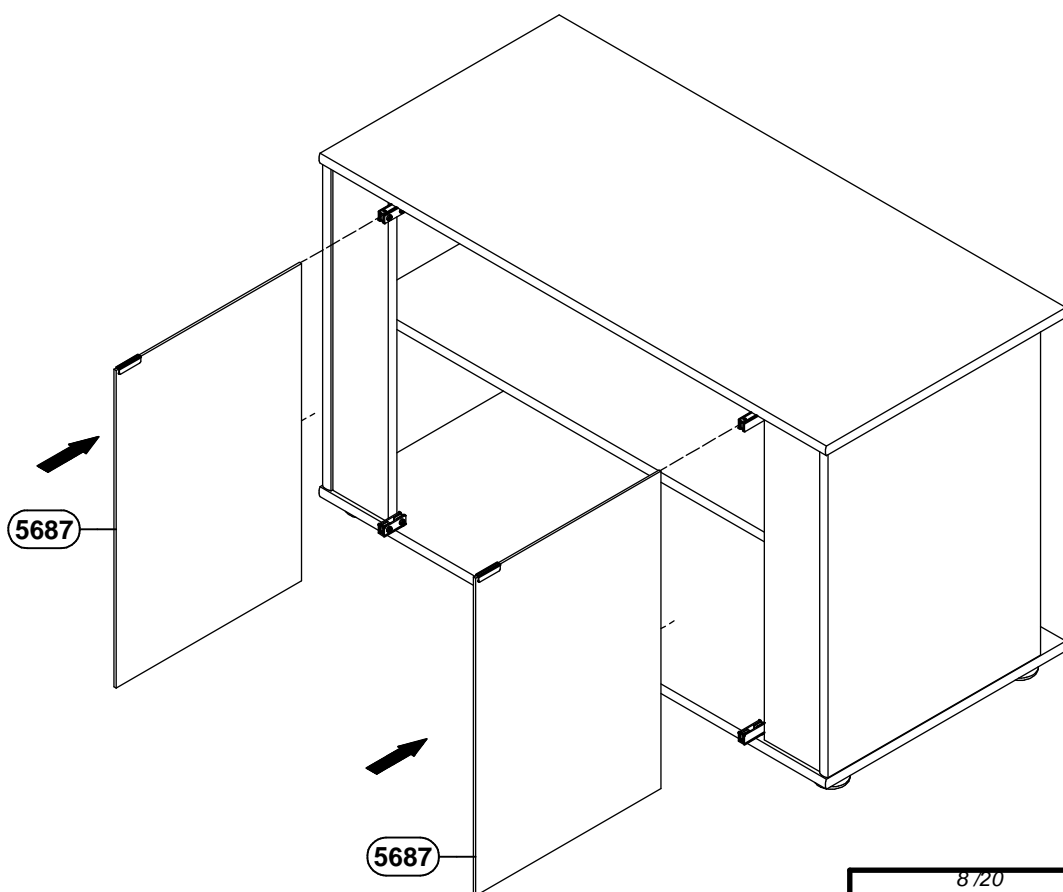

21

Ax4



Aax3

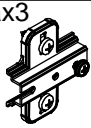

lx8

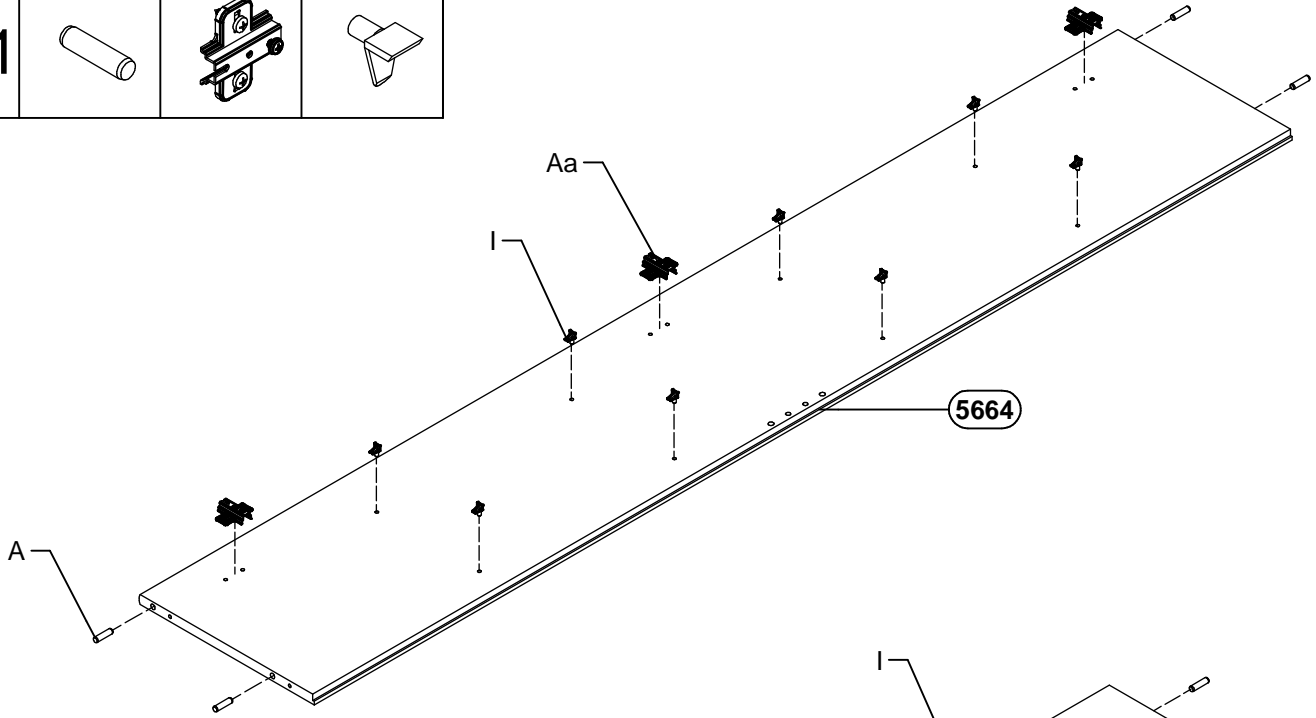

22

Ax4



Jx2



lx8

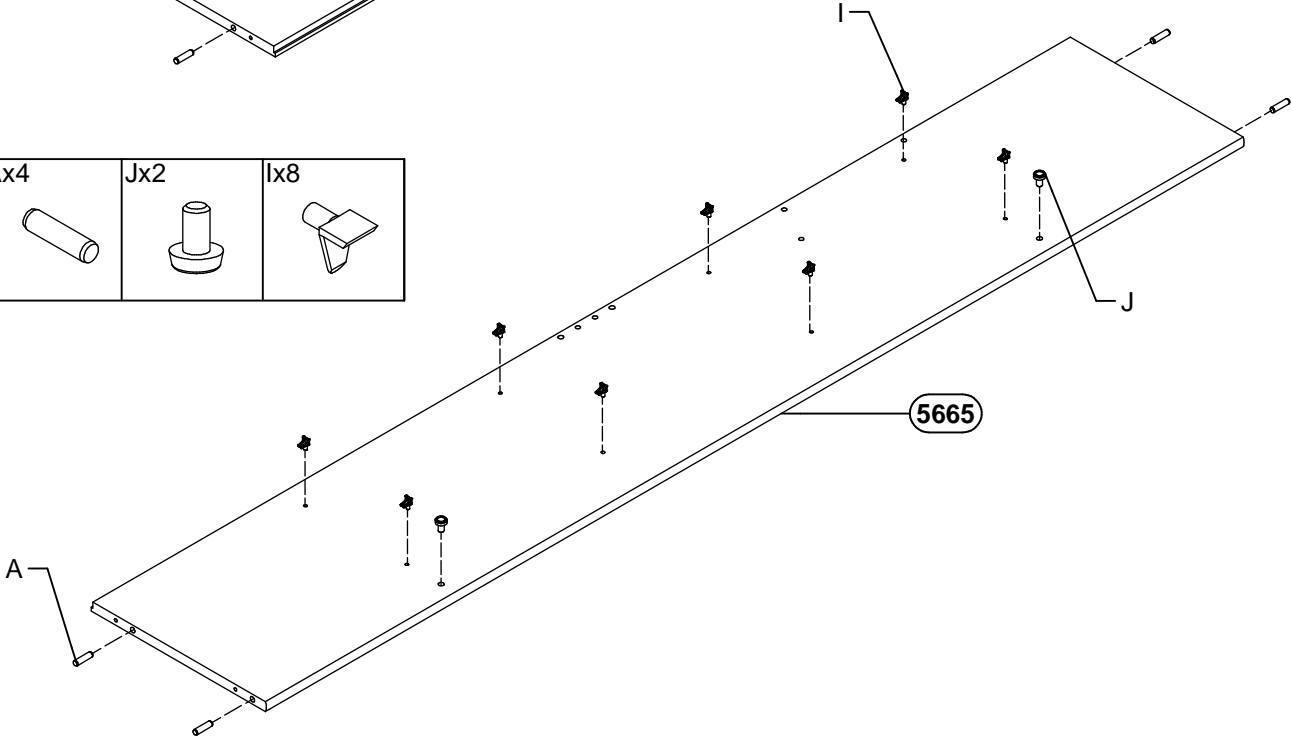

23

Ax4

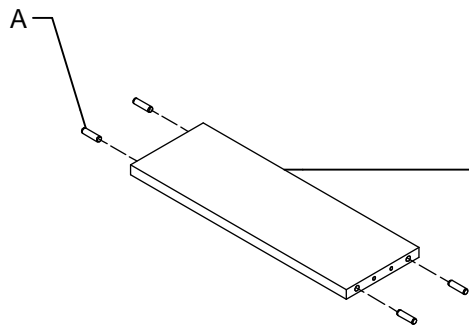

24

Bx4	Ex4
-----	-----

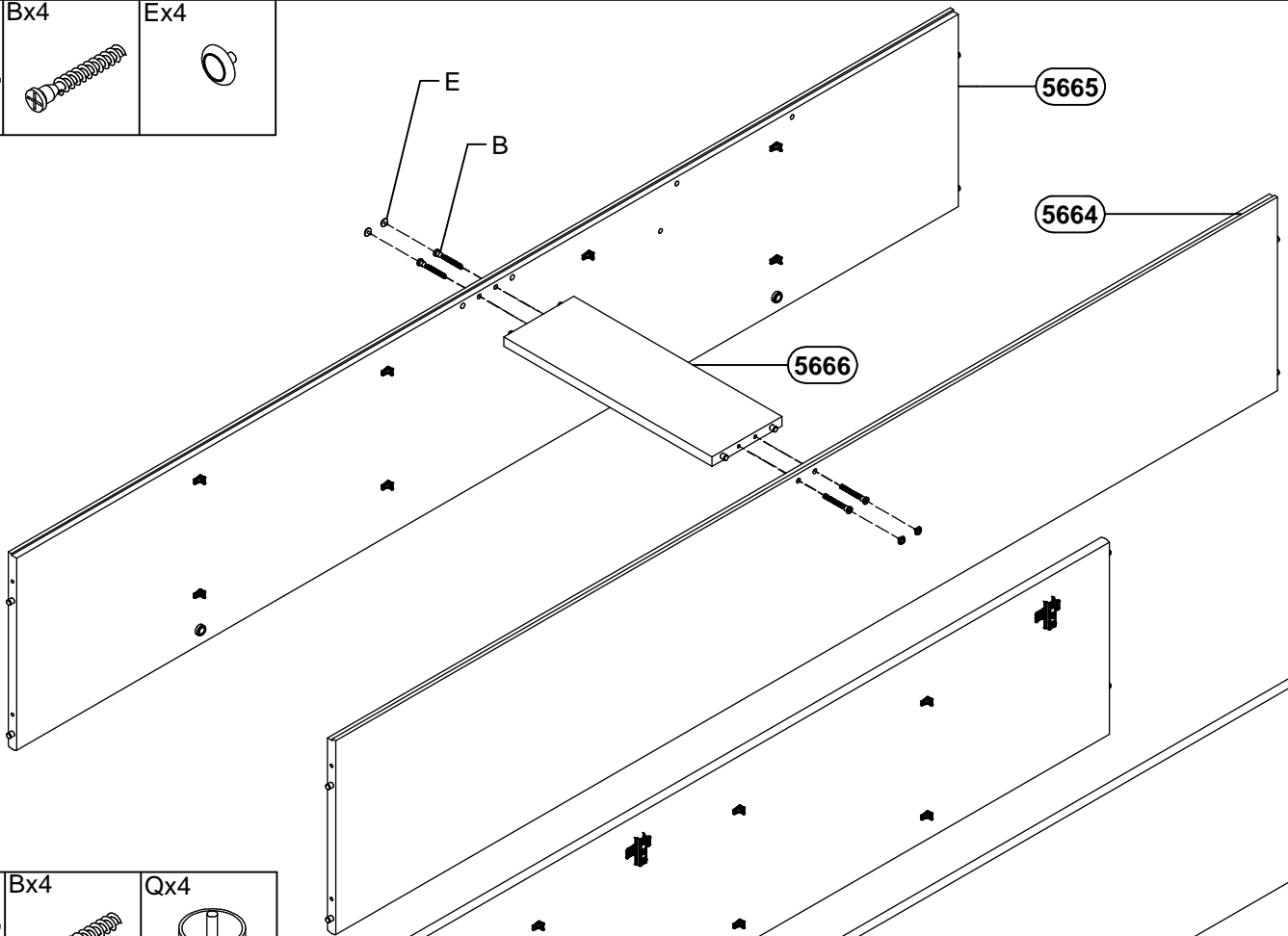

25

Bx4	Qx4
-----	-----

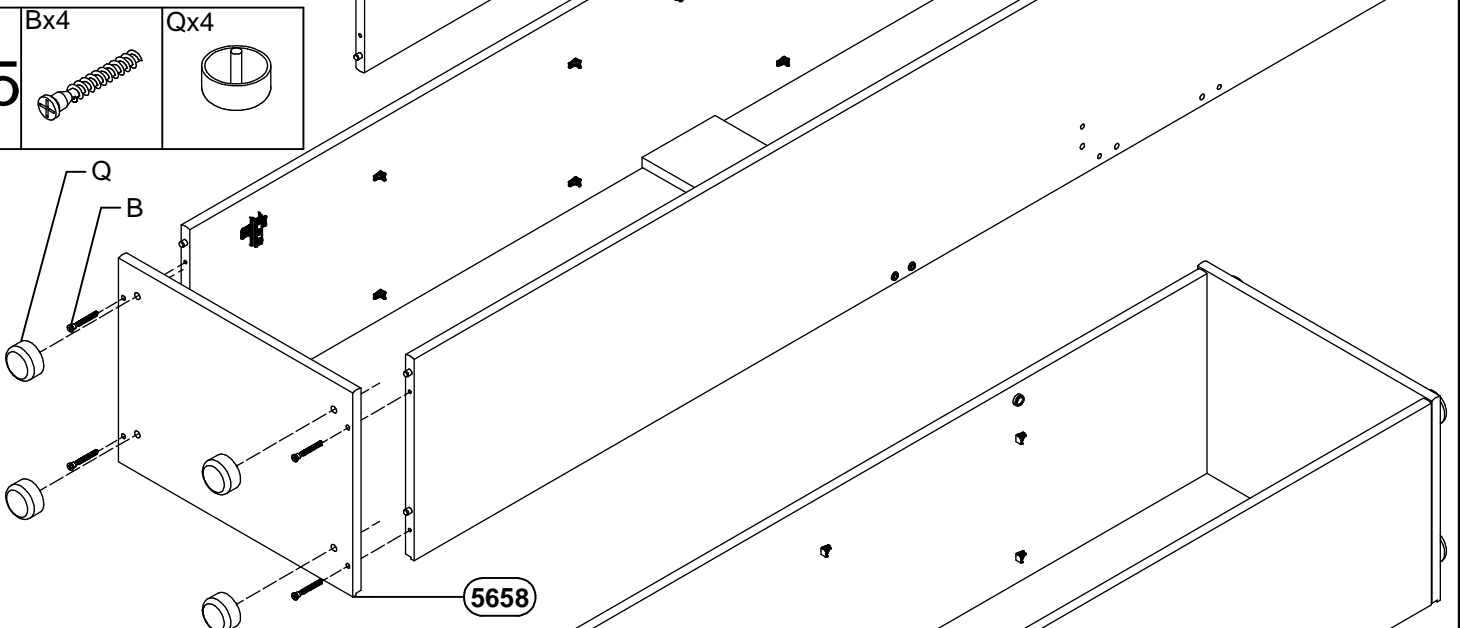

26

Bx4	Ex4
-----	-----

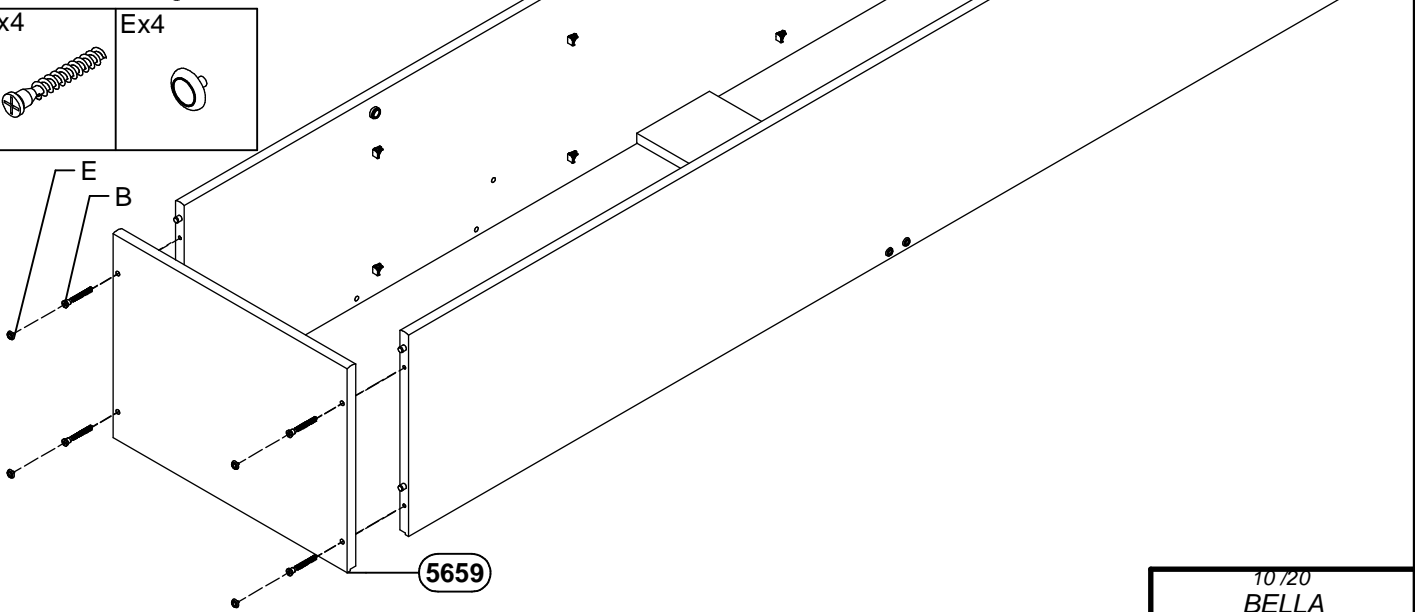

27

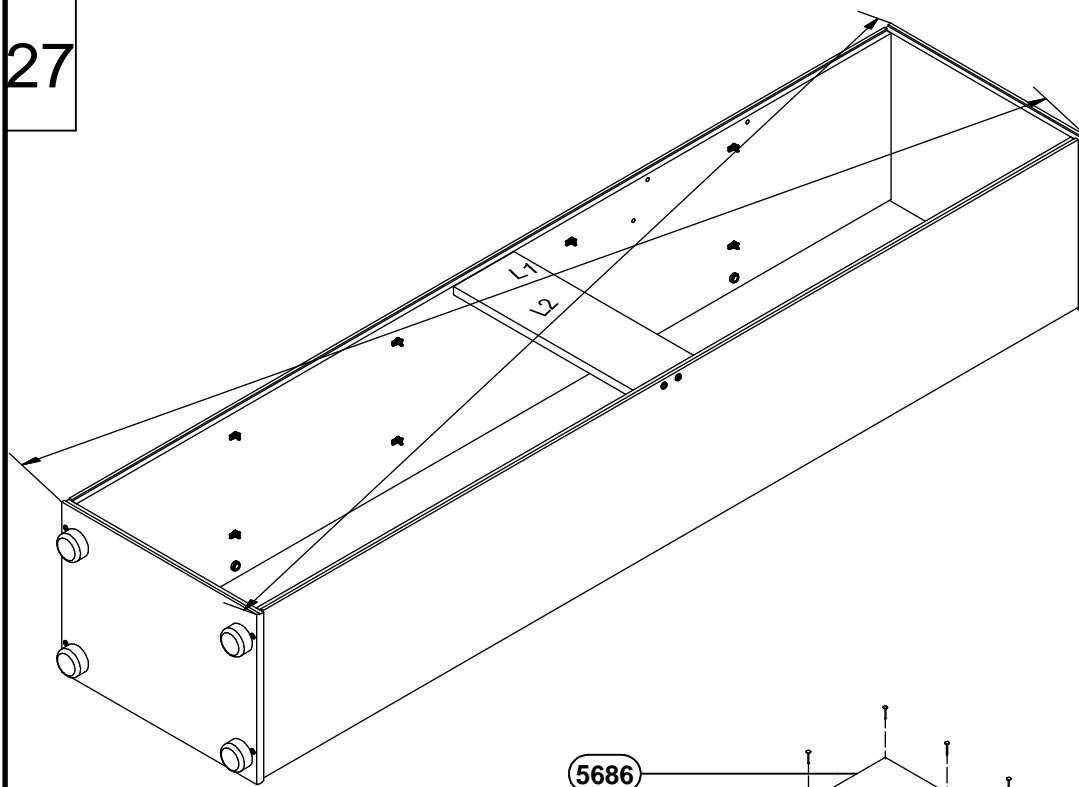

28

Adx28

Rx4

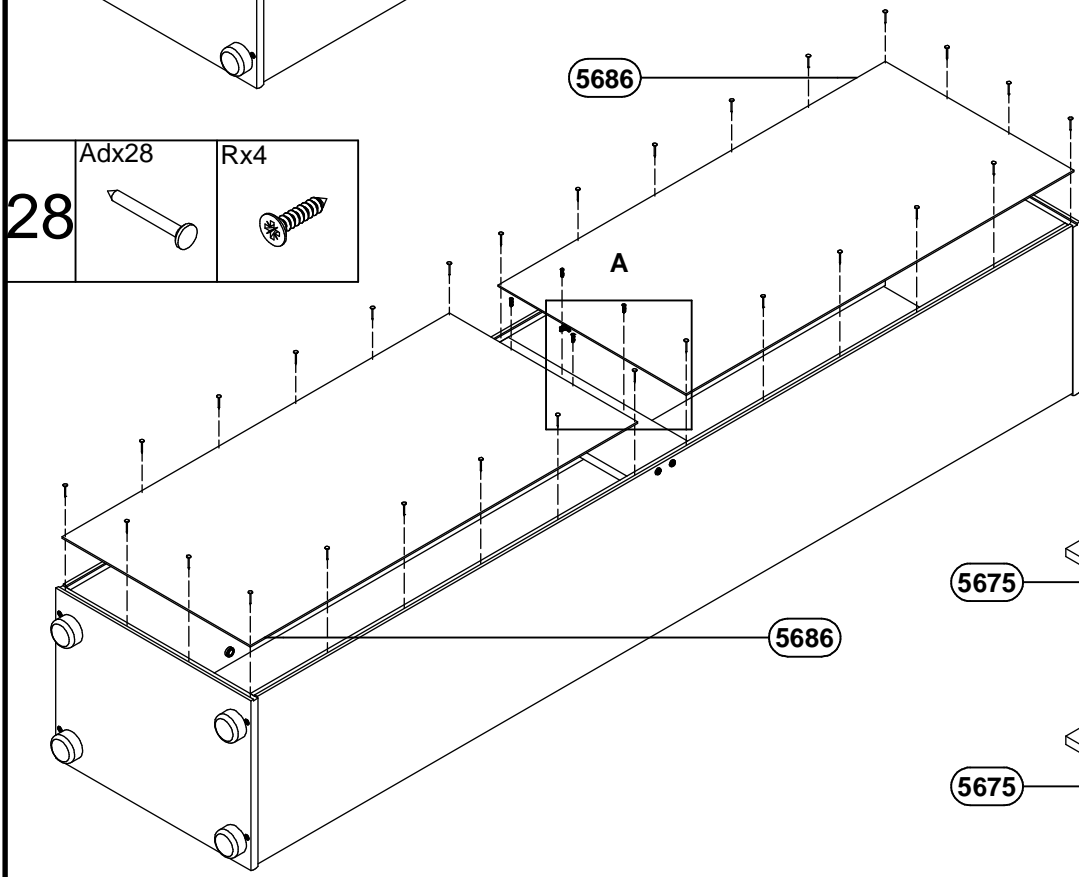

29

5675

5675

5675

5675

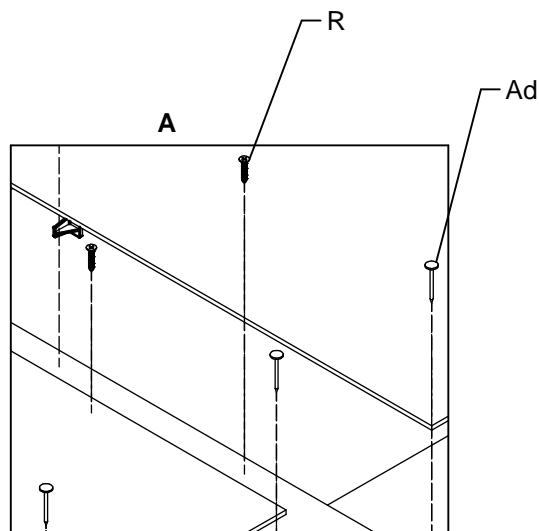
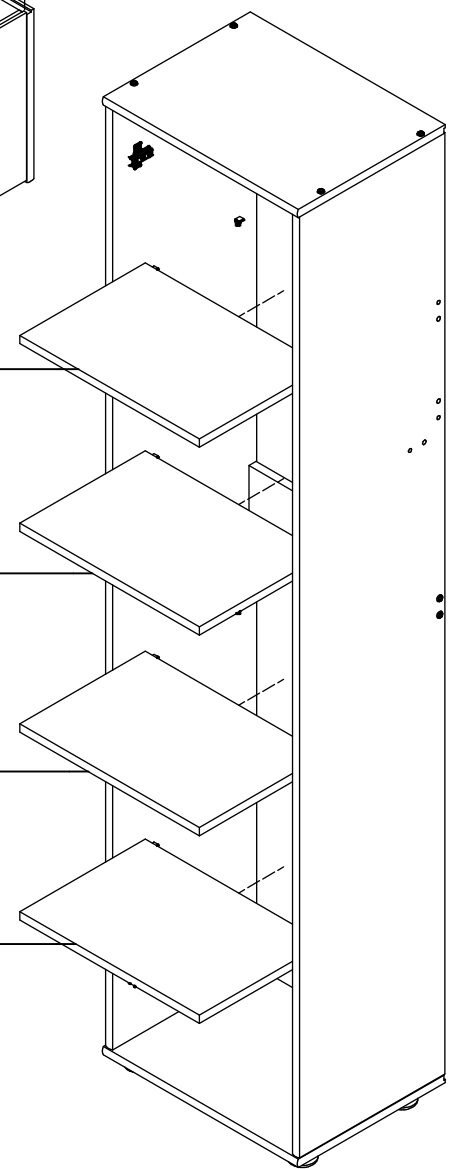

30 Ax2

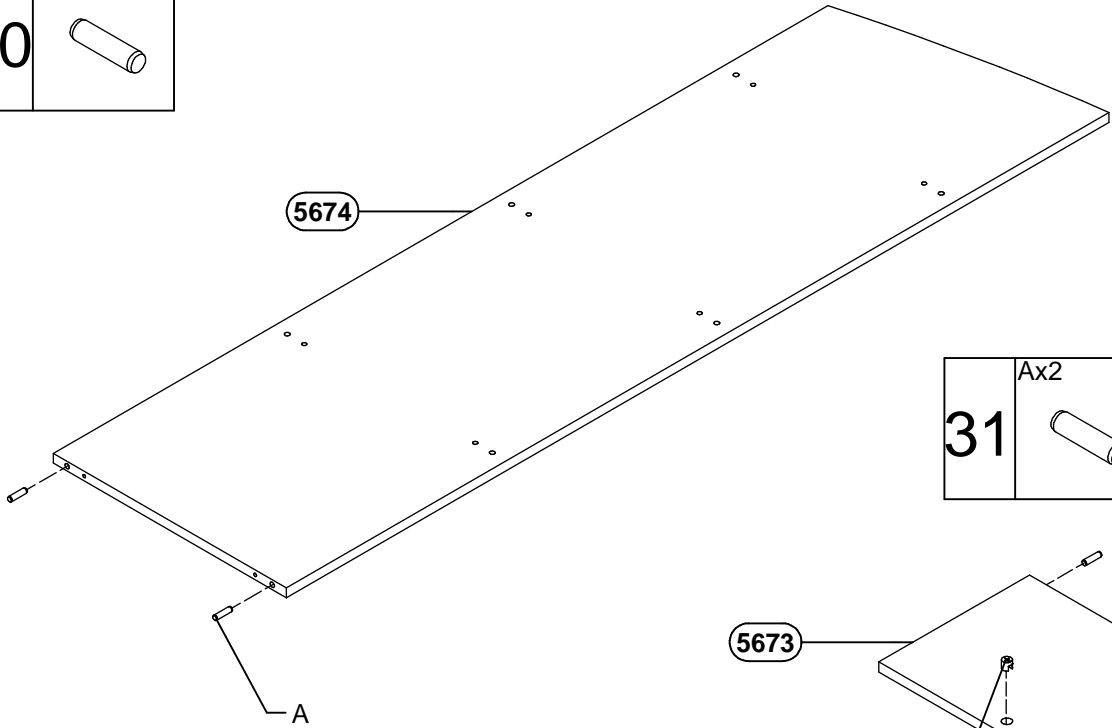
31 Ax2 Dx1

32 Cx3 Ox1 Px1 Nx1

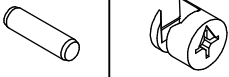
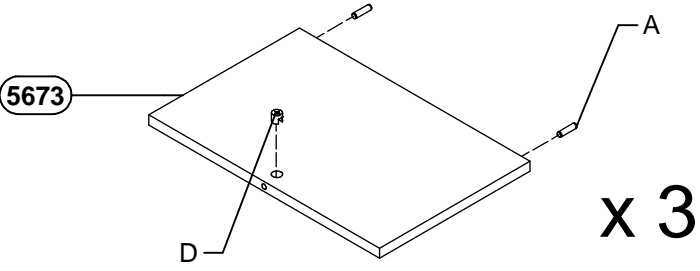

1400mm

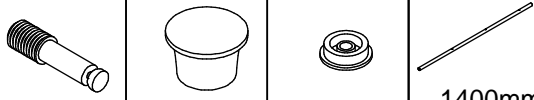

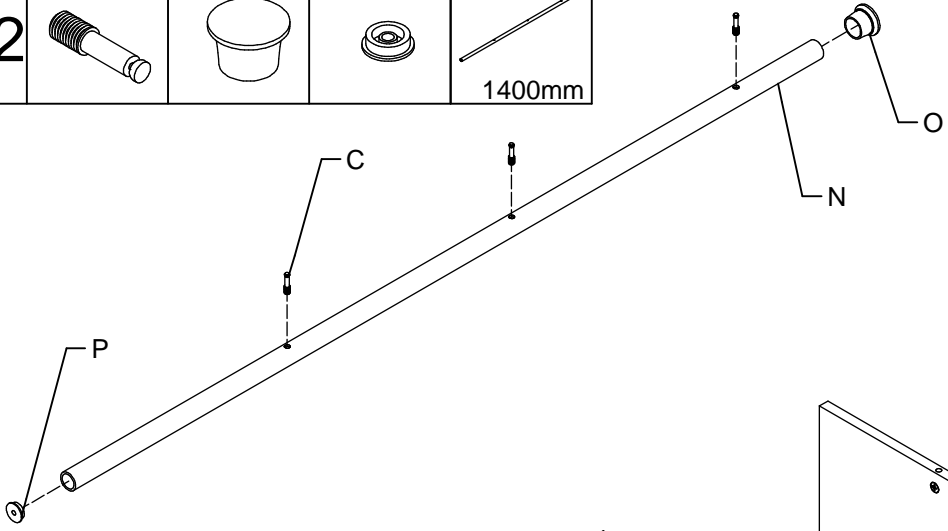
33 Bx6

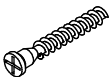
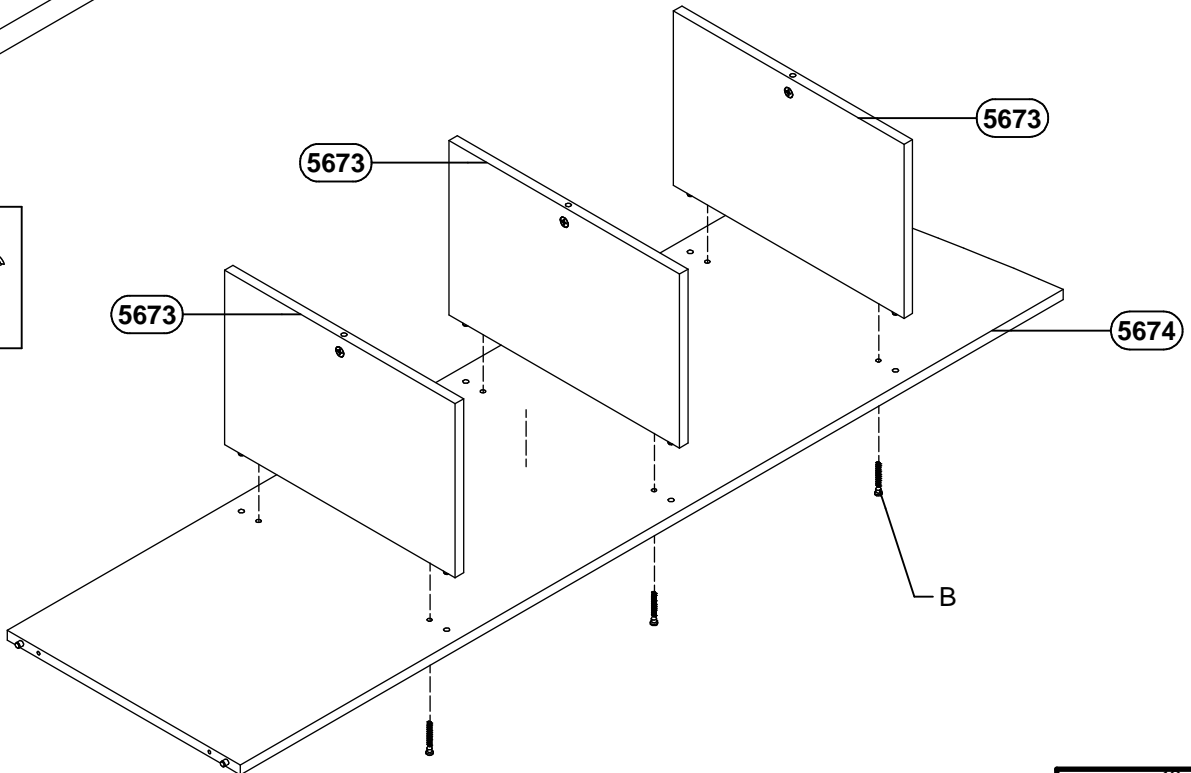
34

Bx2

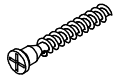

Qx4



5672

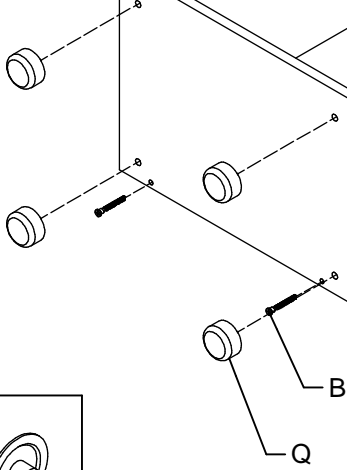

35

Fx3

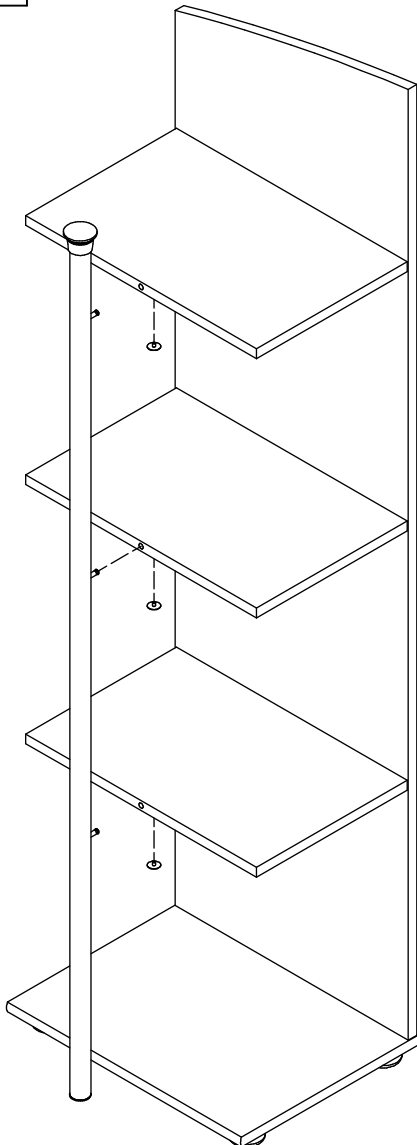

Ax4

36

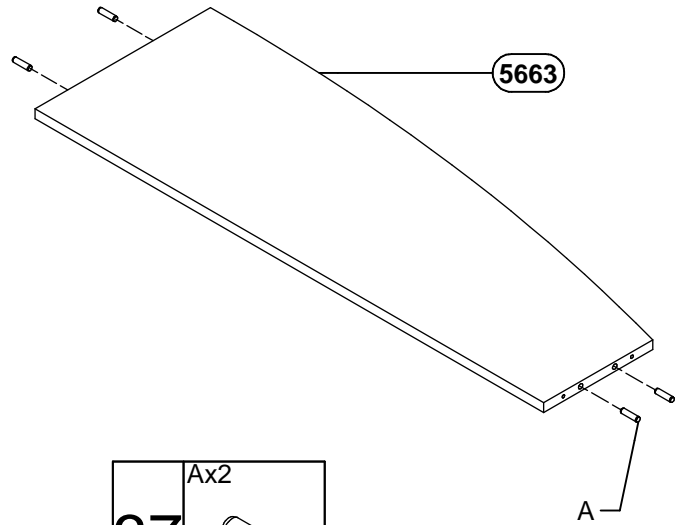

5663

Ax2

37

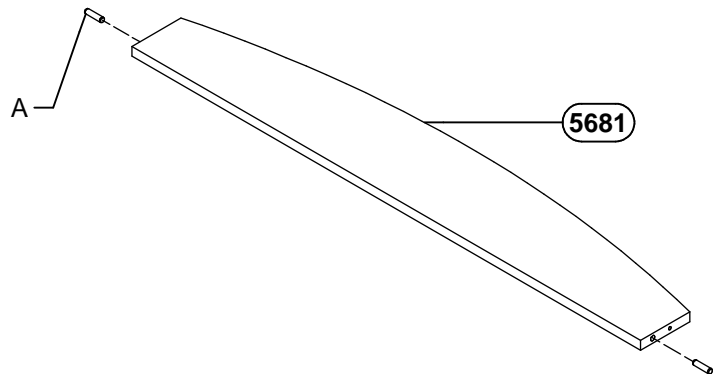

5681

38

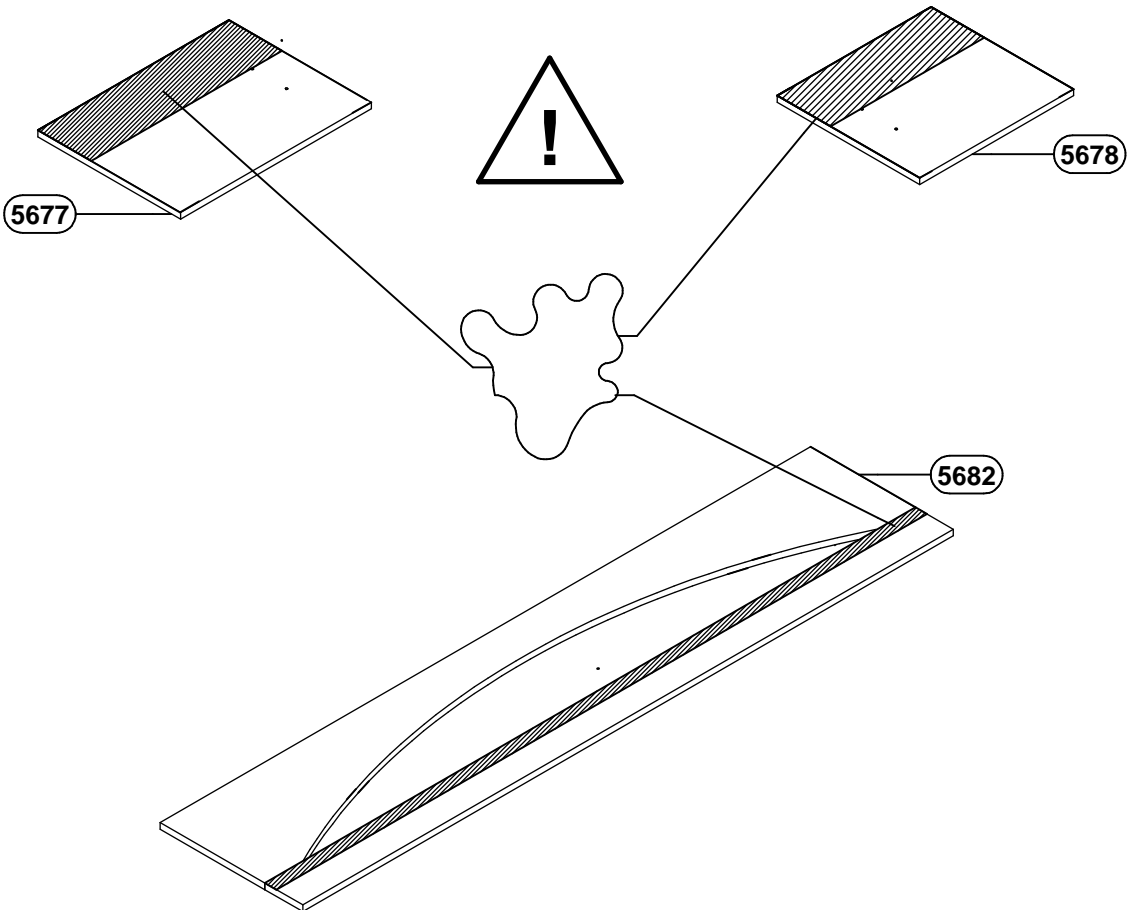

39

Abx1	Abx1	Acx1
431mm	535mm	1825mm

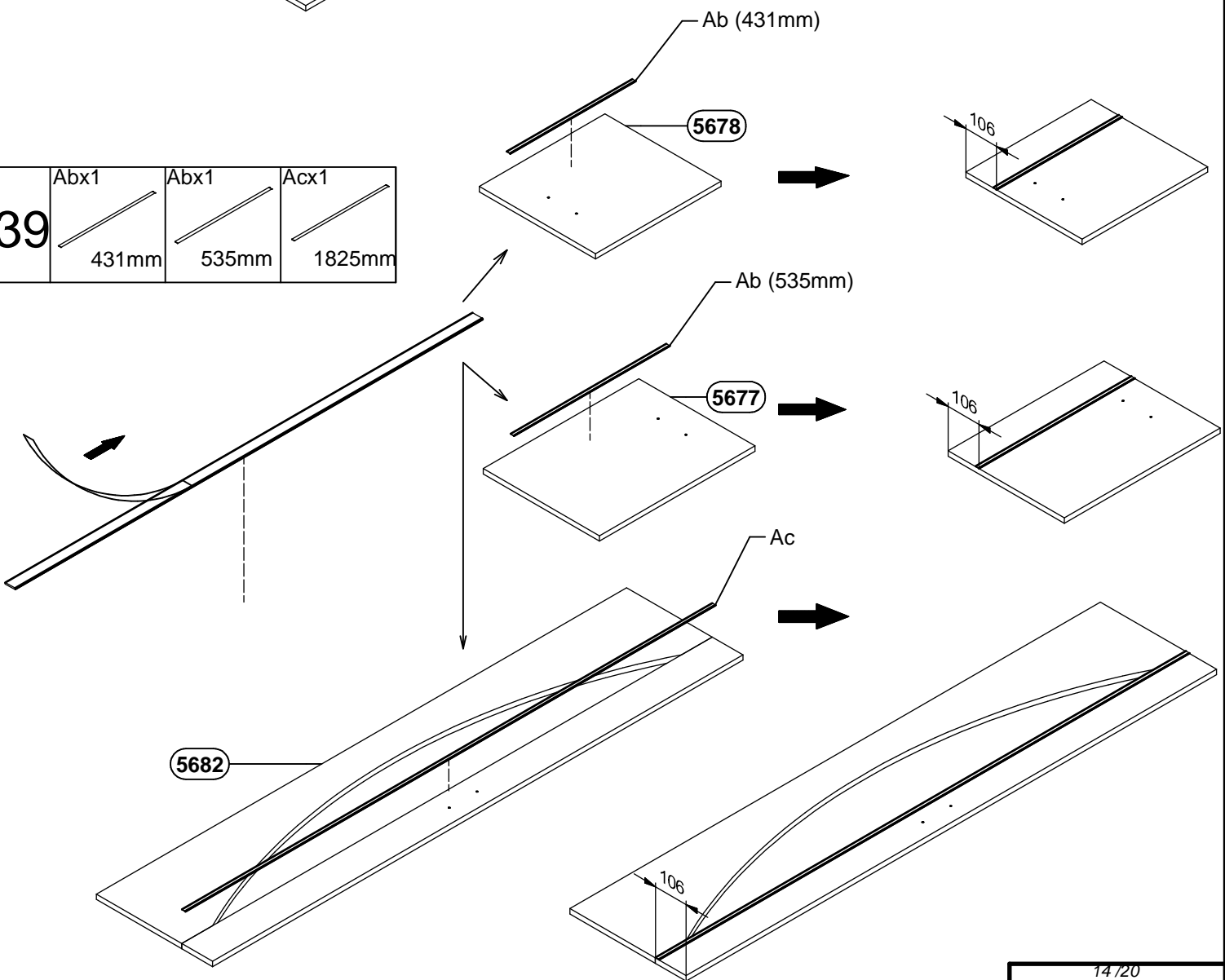

40

Bx6

Ex6

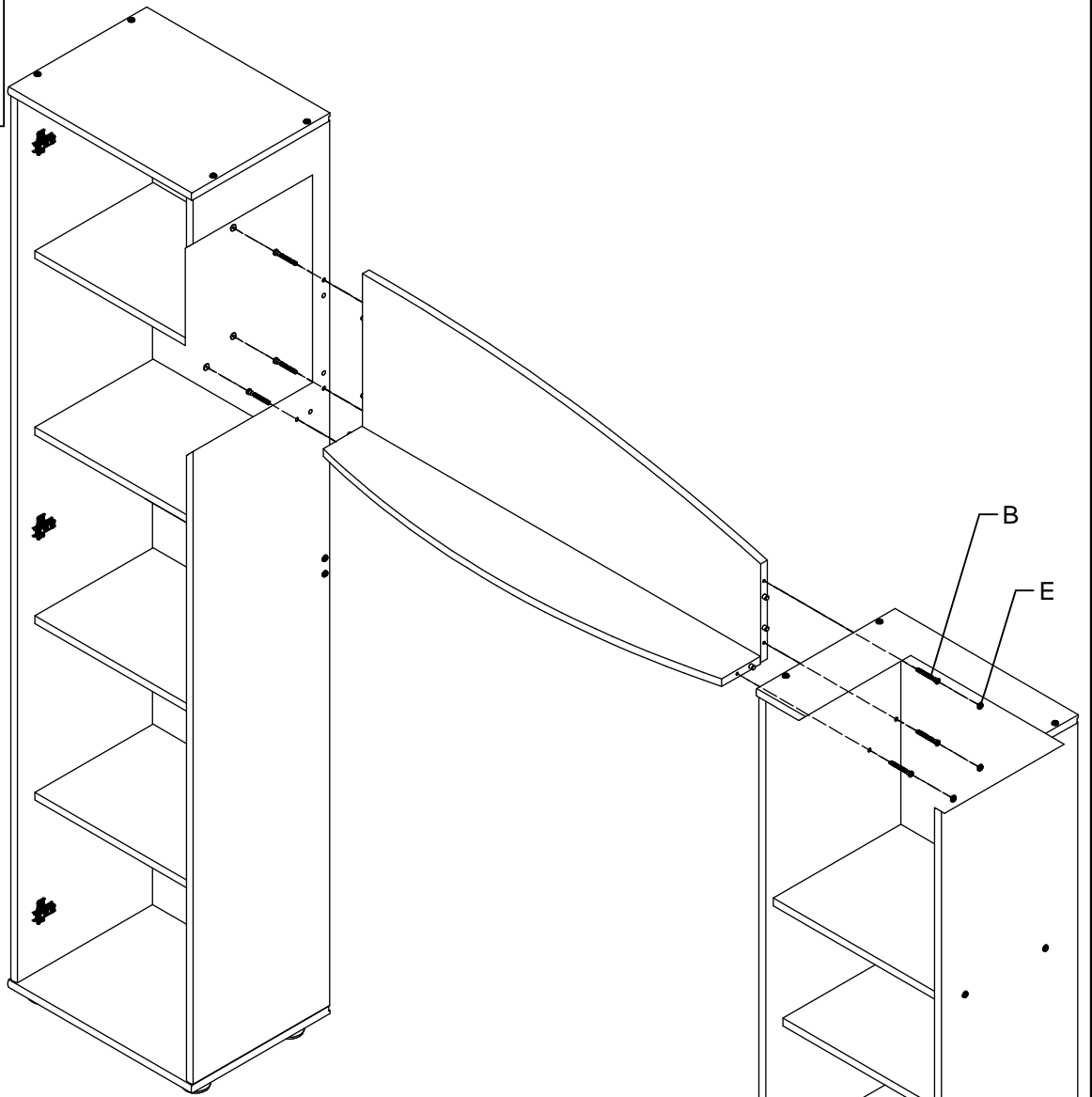
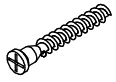

41

Zx2

Gx1

Hx2

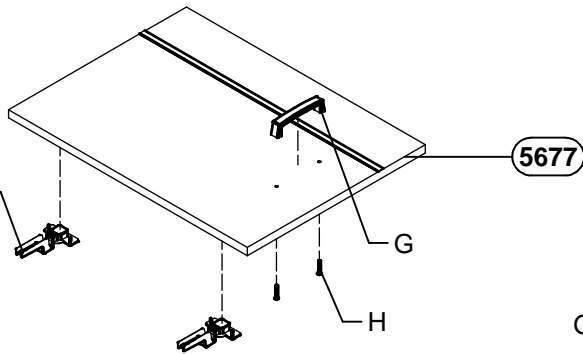
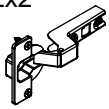

5677

42

Zx2

Gx1

Hx2

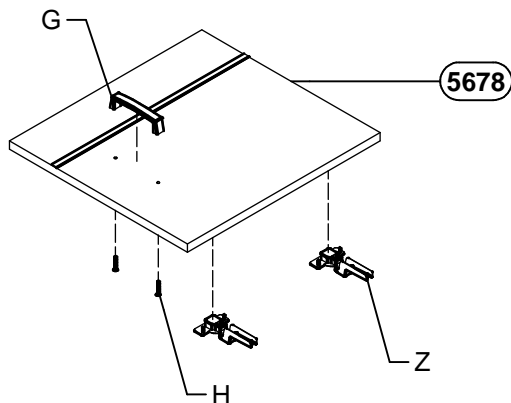
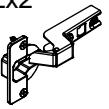

5678

43

Zx3

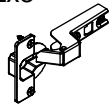

Gx1



Hx2



M4x25

Kx18



Rx18



3x16

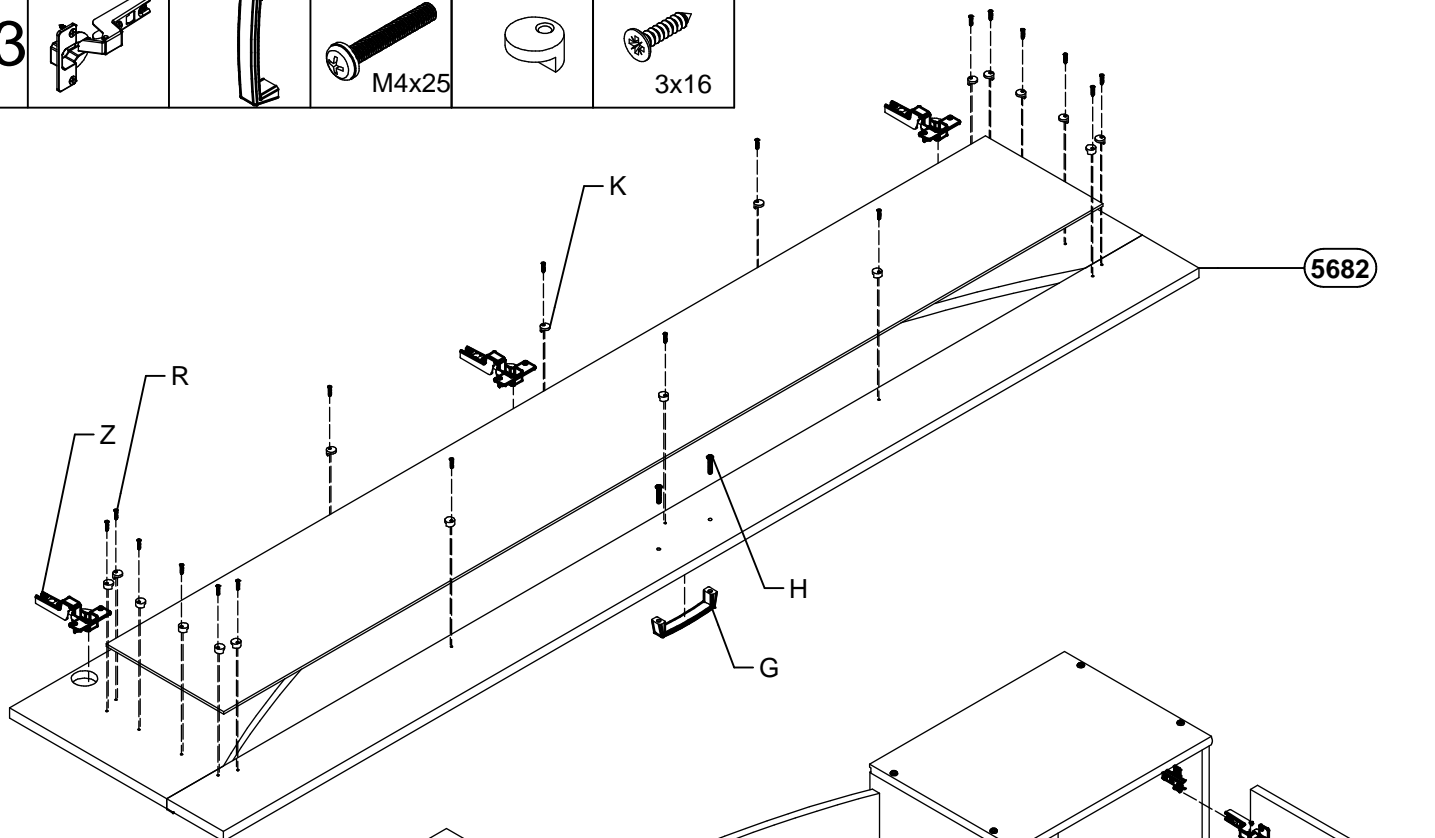

44

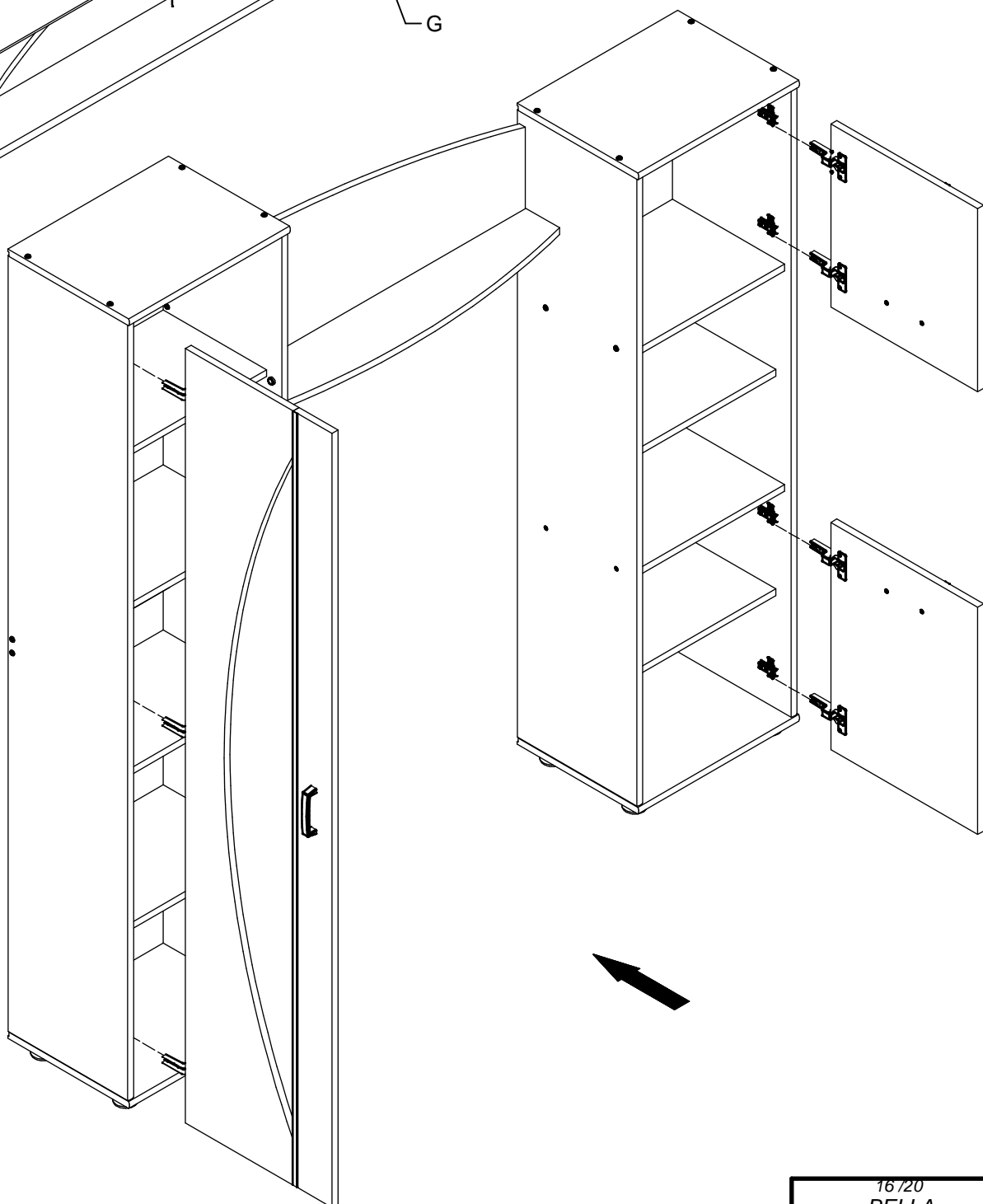

45

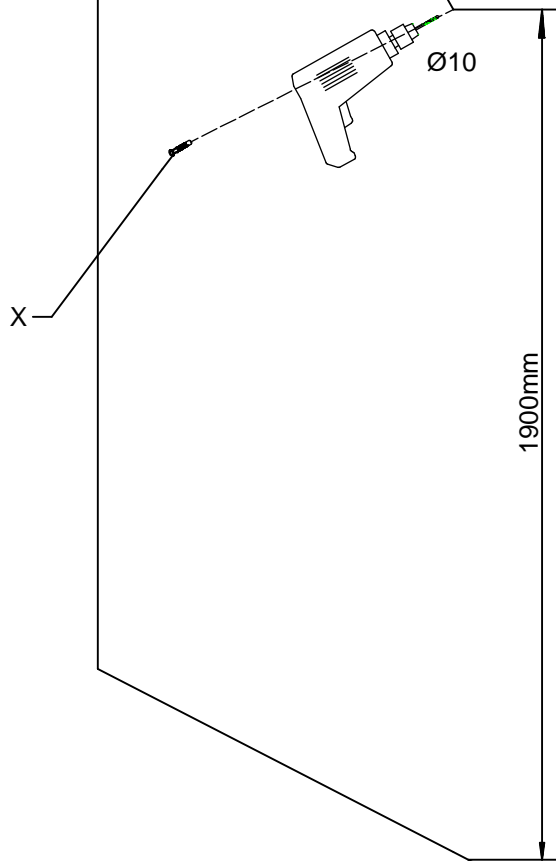
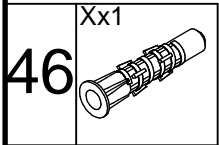
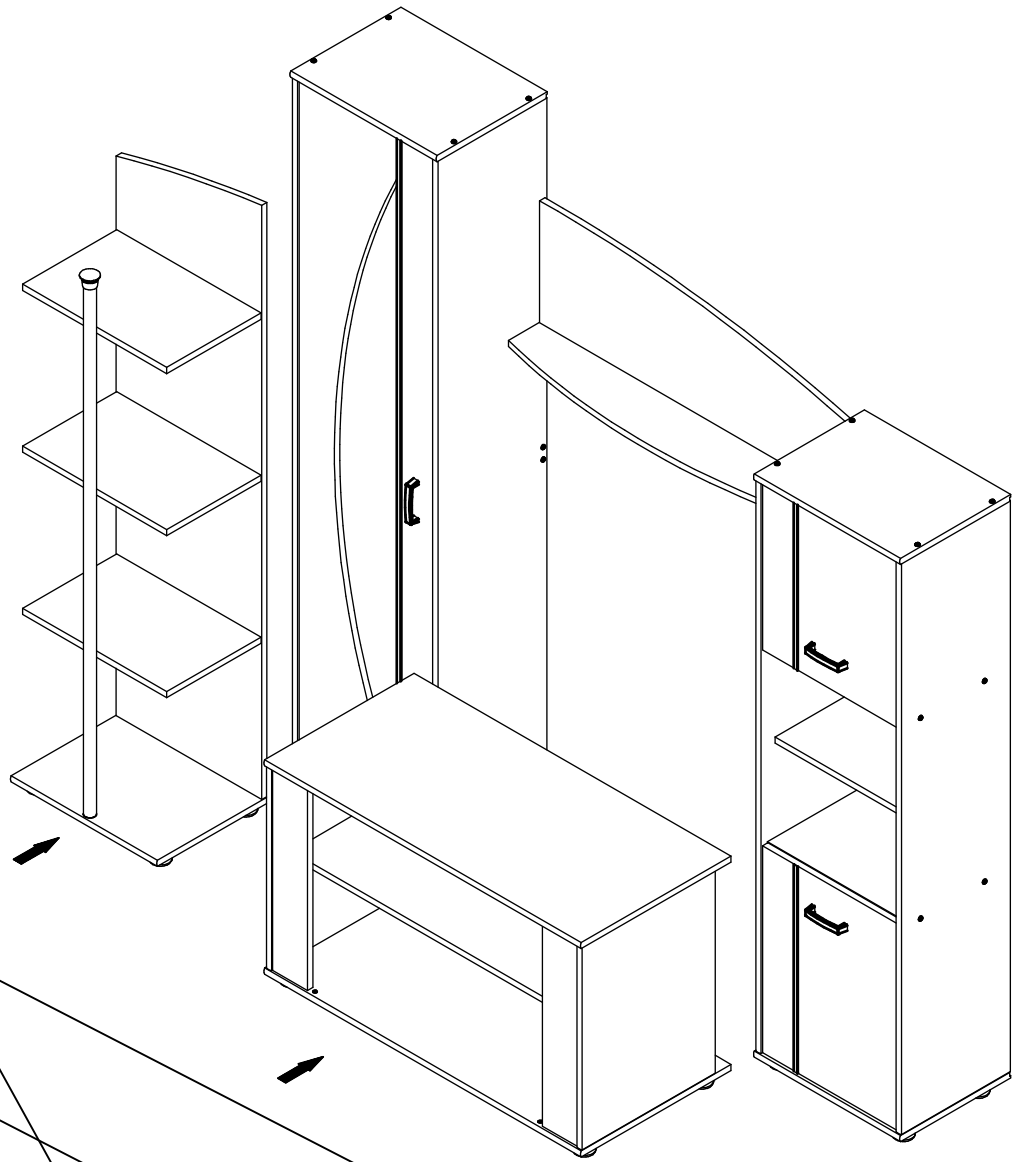

47

Wx1



Sx2



4x16

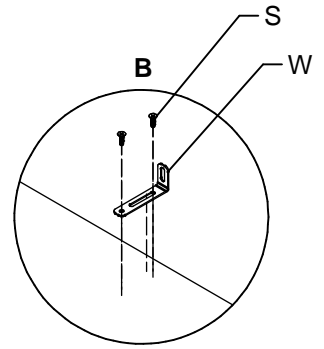
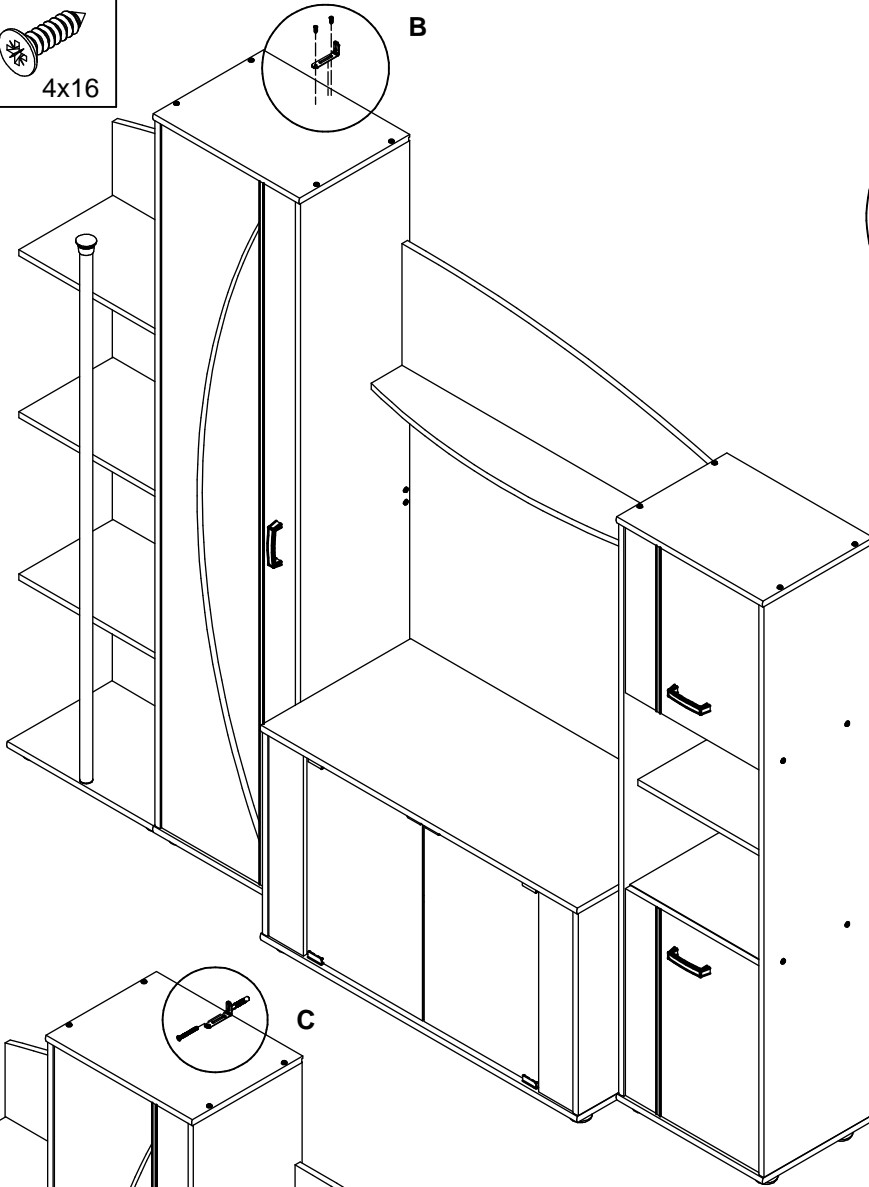

48

Ux1



5x50

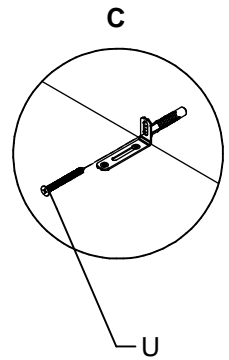
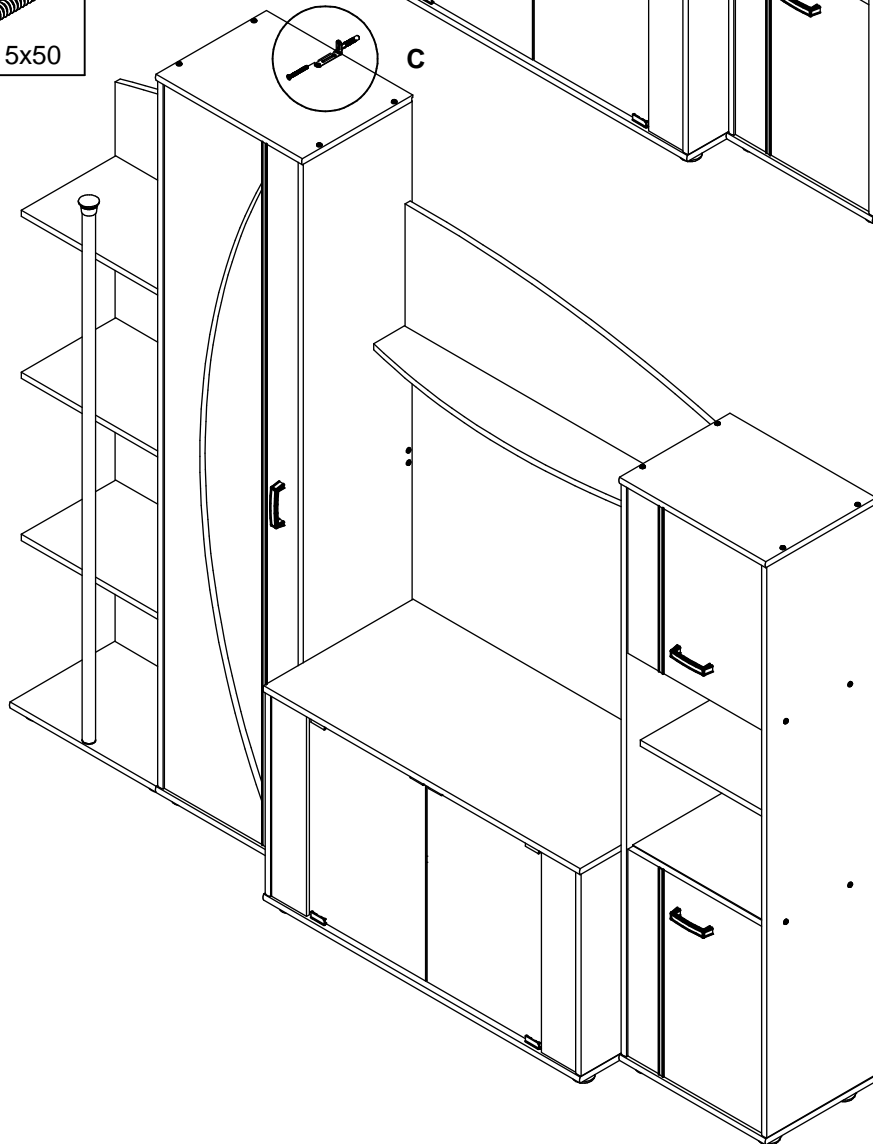

49

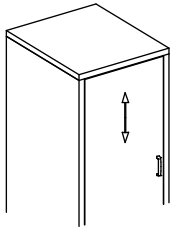
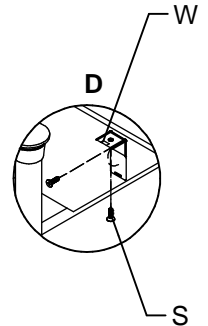
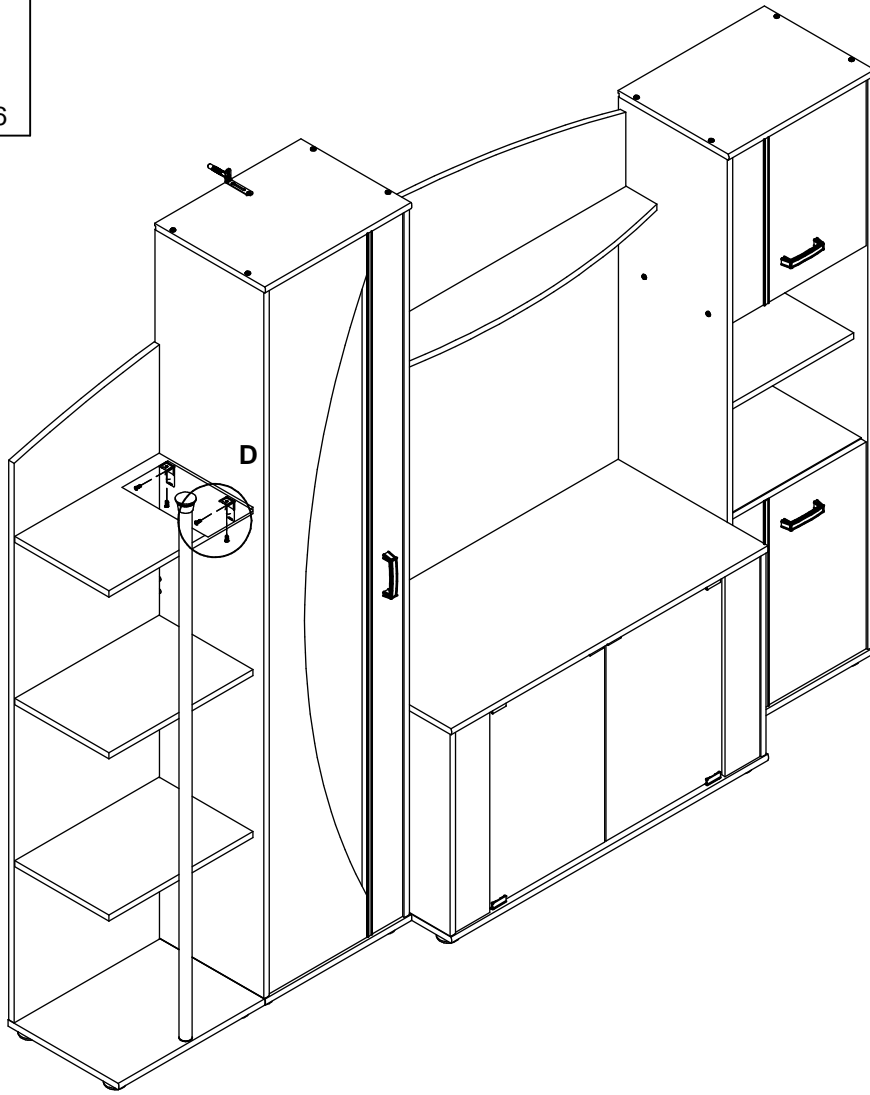
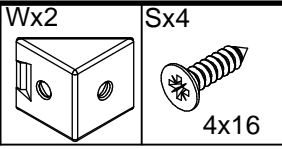

1.

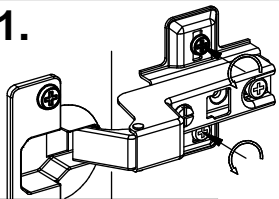

2.

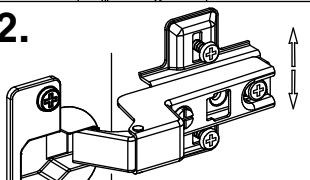

3.

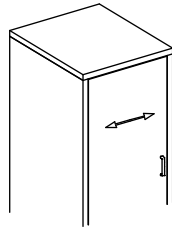
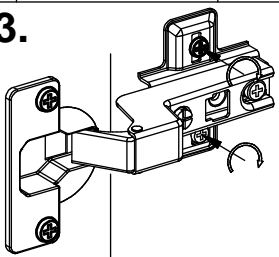

1.

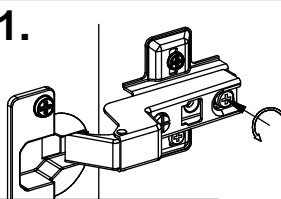

2.

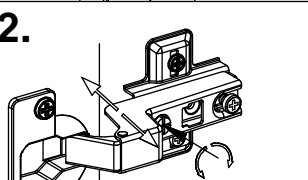

3.

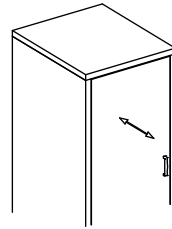
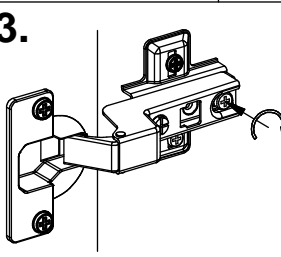

1.

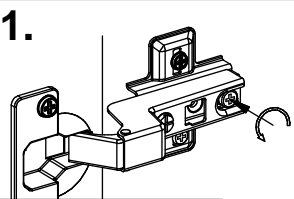

2.

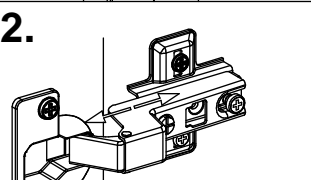

3.

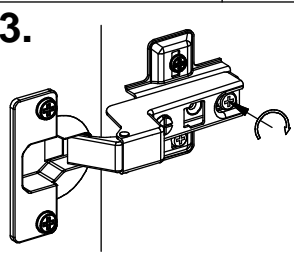



(SRB) (MNE)

Dostavljeni plastični tiplovi su namenjeni za ugradnju na standardan zid od cigle.
Pre ugradnje korisnik je dužan da proveriti da li dostavljeni tiplovi odgovaraju vrsti zida na koji je predviđena ugradnja.
Ukoliko tiplovi ne odgovaraju zidu kupac je u obavezi da u specijalizovanoj radnji sam nabavi odgovarajuće tiplove.

(DE) (AUS) (CH)

Die gelieferten Plastikdübel sind zum Einbau in die standardmässige Ziegelwand bestimmt.
Vor dem Einbau ist der Benutzer verpflichtet zu prüfen, ob die gelieferten Dübel der Art der Wand, auf der der Einbau vorgesehen ist, entsprechen.
Wenn die Dübel der Wand nicht entsprechen, ist der Kunde verpflichtet im Fachhandel entsprechende Dübel selber zu besorgen.

(ESP)

Las clavijas plásticas proporcionadas están destinadas para ser insertadas en un muro estándar en ladrillo.
Antes de la inserción, el utilitario debe verificar si las clavijas proporcionadas convienen al tipo de muro previsto para la inserción.
Si las clavijas no convienen al muro, el comprador debe comprar por sí mismo las clavijas correspondientes en una tienda especializada.

(RUS) (BLR)

Доставлените пластмасови котви са направени за вграждане в стандартен зид от цигли. Преди вграждане ползвателят е длъжен да провери дали доставлените котви отговарят на вида зид, за който са предвидени за вграждане.

(SLO)

Dostavljeni plastični nosilci so namenjeni za montažo na standardni zid iz opeke. Pred montažo je uporabnik dolžan preveriti ali dostavljeni nosilci odgovarjajo vrsti zidu, na katerem je predvidena montaža. V kolikor nosilci niso primerni je kupec dolžan kupiti nosilce, ki odgovarjajo montaži.

(ROU)

Tiplurile din plastic transmise sant prevazute exclusiv pentru peretii standard din caramida. Inainte de instalare beneficiarul este obligat sa verifice daca tiplurile transmise corespund peretelui pe care se prevede instalarea. In cazul in care tiplurile nu corespund peretelui, cumparatorul este obligat sa achizitioneze singur tiplurile corespunzatoare din magazinele specializate.

(BGR)

Доставените пластмасови котви са направени за вграждане в стандартен зид от цигли. Преди вграждане ползвателят е длъжен да провери дали доставените котви отговарят на вида зид, за който са предвидени за вграждане. Ако котвите не отговарят на зида на купувача, то той задължително трябва за закупи от специализиран доставчик отговарящите по вид котви.

(MKD)

Доставените пластични типли наменети се за прикачување на стандарден зид од цигла. Пред прикачувањето корисникот е должен да провери дали доставените типли одговараат на видот на зидот на кој е предвидено прикачувањето. Доколку типлите не одговараат купувачот е должен сам да набави во специјализирана продавница типли кои одговараат.



(ENG)

Delivered plastic plugs are intended for fitting on a standard brick wall. Before fitting them, the buyer needs to check if the delivered plugs are suitable for the wall on which they plan to use them on.
If the plugs don't fit the wall, the buyer has to visit a specialized store and get the suitable plugs themselves.

(FRA) (CH)

Les chevilles plastiques fournies sont destinées à être insérées dans un mur standard en briques.
Avant l'insertion, l'utilisateur est tenu à vérifier si les chevilles fournies conviennent au type du mur prévu pour l'insertion.
Si les chevilles ne conviennent pas au mur, l'acheteur est tenu à acheter tout seul les chevilles appropriées dans un magasin spécialisé.

(ITA) (CH)

I tasselli di plastica consegnati sono destinati al montaggio su un muro di mattoni standard. Prima del loro montaggio, l'acquirente deve controllare se i tasselli forniti sono adatti per la parete su cui si prevede di utilizzarli. Se i tasselli non sono adatti alla parete, devono essere acquistati presso una ferramenta.

(CZ) (SK)

Dodané plastové hmoždinky jsou určeny pro montáž na standardní cihlovou stěnu. Před začátkem montáže, kupující je povinnen dohlédnout na správnost typu dodaných hmoždinek, vzhledem na typ stěny určené k montáži.
Pokud hmoždinky dodané výrobcem neodpovídají typu stěny určené k montáži, kupující je povinnen pořídit si správný typ ve specializované prodejně.

(GR)

Τα διαβιβασμένα πλαστικά βύσματα συγκράτησης προορίζονται για την ενσωμάτωση σε πρότυπο τοίχο από τούβλα.
Προ της ενσωμάτωσης ο χρήστης πρέπει να ελέγξει εάν τα διαβιβασμένα βύσματα συγκράτησης ανταποκρίνονται στο είδος του τοίχου στον οποίο προβλέπεται η ενσωμάτωση.
tz:Εφόσον τα βύσματα συγκράτησης δεν ανταποκρίνονται στον τοίχο ο αγοραστής υποχρεούται να προμηθευτεί μόνος του σε ειδικευμένο μαγαζί κατάλληλα βύσματα συγκράτησης.

(CRO) (BiH)

Dostavljeni plastični tiplovi su namijenjeni za ugradnju na standardan zid od cigle. Prije ugradnje korisnik je dužan da provjeri da li dostavljeni tiplovi odgovaraju vrsti zida na koji je predviđena ugradnja.
Ukoliko tiplovi ne odgovaraju zidu kupac je u obavezi da u specijaliziranoj radnji sam nabavi odgovarajuće tiplove.

(HU)

A kézbesített műanyag tiplik standard téglafal beépítésére szolgál. Beépítés előtt a felhasználó köteles leellenőrizni hogy a tiplik megfelelnek e a fal fajtájának mielőtt beépíti. Ha a tiplik nem felelnek meg a vásárló köteles maga beszerezni az erre szakosodott bolt a megfelelő tiplit.

(ALB)

Plastike priza jepen janë të dizajnuara për instalim në një mur me tulla standard. Para instalimit e përdoruesit është e nevojshme për të verifikuar se paraqitur ancorave mur llojit të përshtatshme për ndërtimin e së cilës është planifikuar. Nëse ju nuk i përshtatet blerësi priza muri është i detyruar të dyqaneve të specializuara të shkojë ancorave duhur.