

MEUBLES
DEMEYERE

SAV
SPAREPARTS
KUNDEDIENST
POST VENTAS
SERVICE NA VERKOOP
SERVIZIO POST-VENDITA
SERVICO DEPOIS DE VENDA
SERWIS POGWARANCYJNY

1085 0 24-Dec-09

1085 0

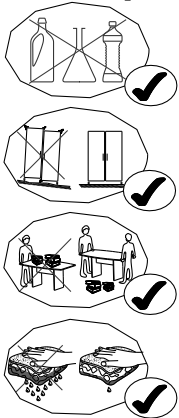

REP	DIM	QTE
1	1622 x 499	2
2	812 x 500	2
3	1636 x 395	2
4	780 x 395	1
5	1650 x 808	1

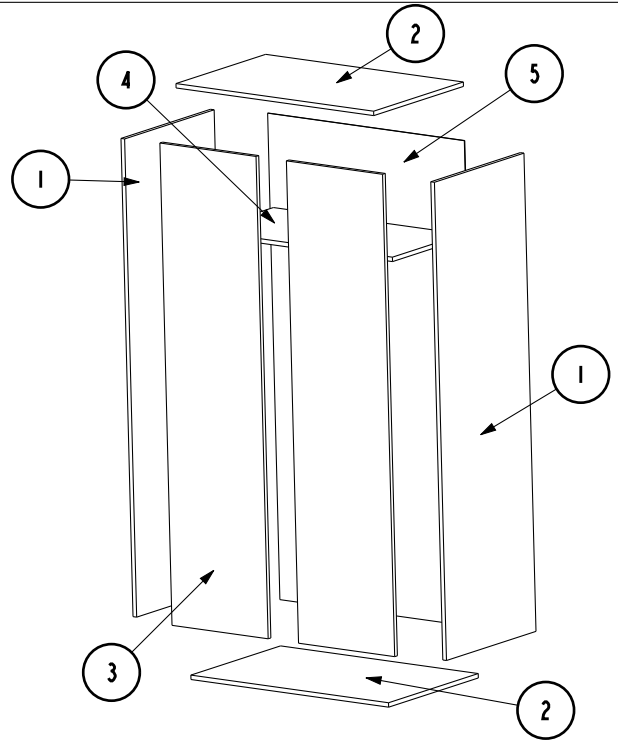

916 X4 VBA TR 4x13	907 X2 VBA TR 3x16
353005 X1 	434 X 1
706 X 4 	310056 X1
340750 X 8 	333009 X 6
935 X 2 	332169 X 2
310040 X 2 	918 X 4
	2707 X4
	604757 X1
	700 X 1
	333011 X 6
	949 X 12

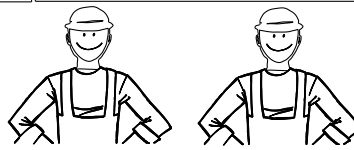

1H 00M N

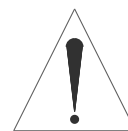

FR SECURITE
RESPECTER LES INSTRUCTIONS DE MONTAGE DECRITES DANS LA NOTICE.

EN CAUTION
FOLLOW CAREFULLY THE ASSEMBLING INSTRUCTIONS DESCRIBED IN THE DIRECTIONS.

DE SICHERHEITSVORSCHRIFTEN
BEACHTEN SIE BITTE UNBEDINGT DIE ANGEGEBENEN AUFBAUVORSCHRIFTEN.

ES SEGURIDAD
RESPECTAR LAS INSTRUCCIONES DE MONTAJE DESCRIBIDAS EN EL FOLLETO.

NL VEILIGHEID
DE IN DE GEBRUIKSAANWIJZING BESCHREVEN INSTRUCTIES RESPECTEREN.

IT SICUREZZA
RISPETTARE LE ISTRUZIONI DI MONTAGGIO DESCRITTE NEEL 'AVVERTENZA.

PT SEGURANCA
RESPEITAR AS INSTRUCOES DE MONTAGEM DESCRIVIDAS NA INSTRUCOES DE USO.

PL UWAGA
PROSZE, PRZESTRZEGAC INSTRUKCJI MONTAZU.

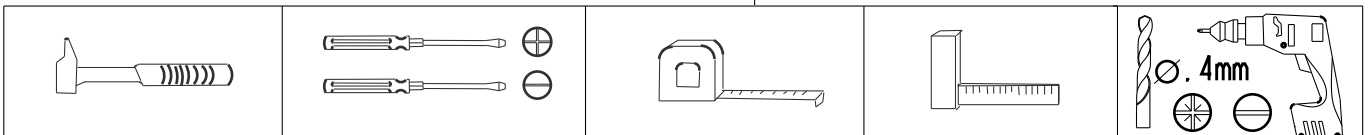

FABRICATION FRANCAISE

1

333009 X 6

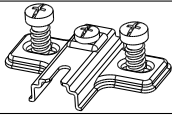

X 2

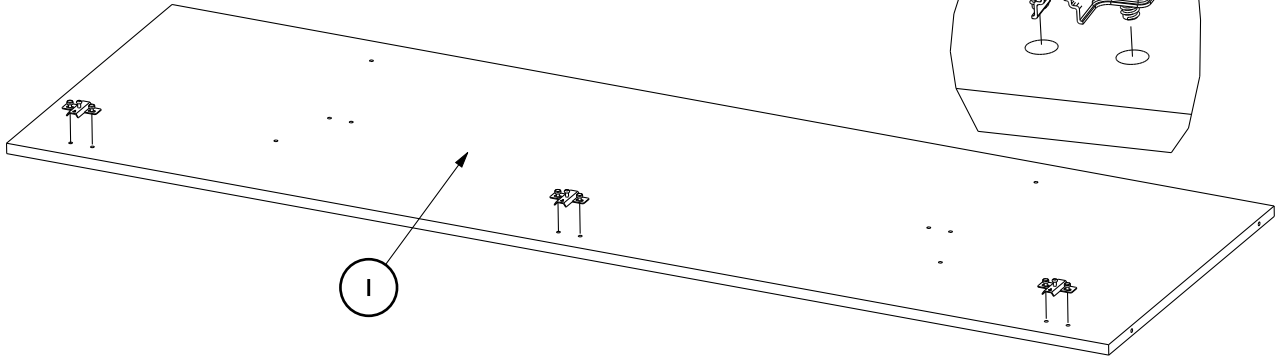
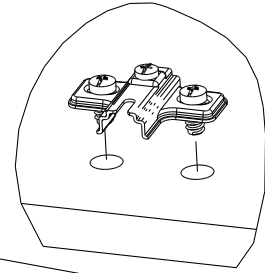

2

340750 X 8

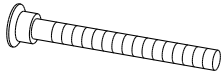

6 PANS 7x50

434

X 1

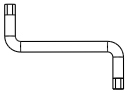

45,5 mm

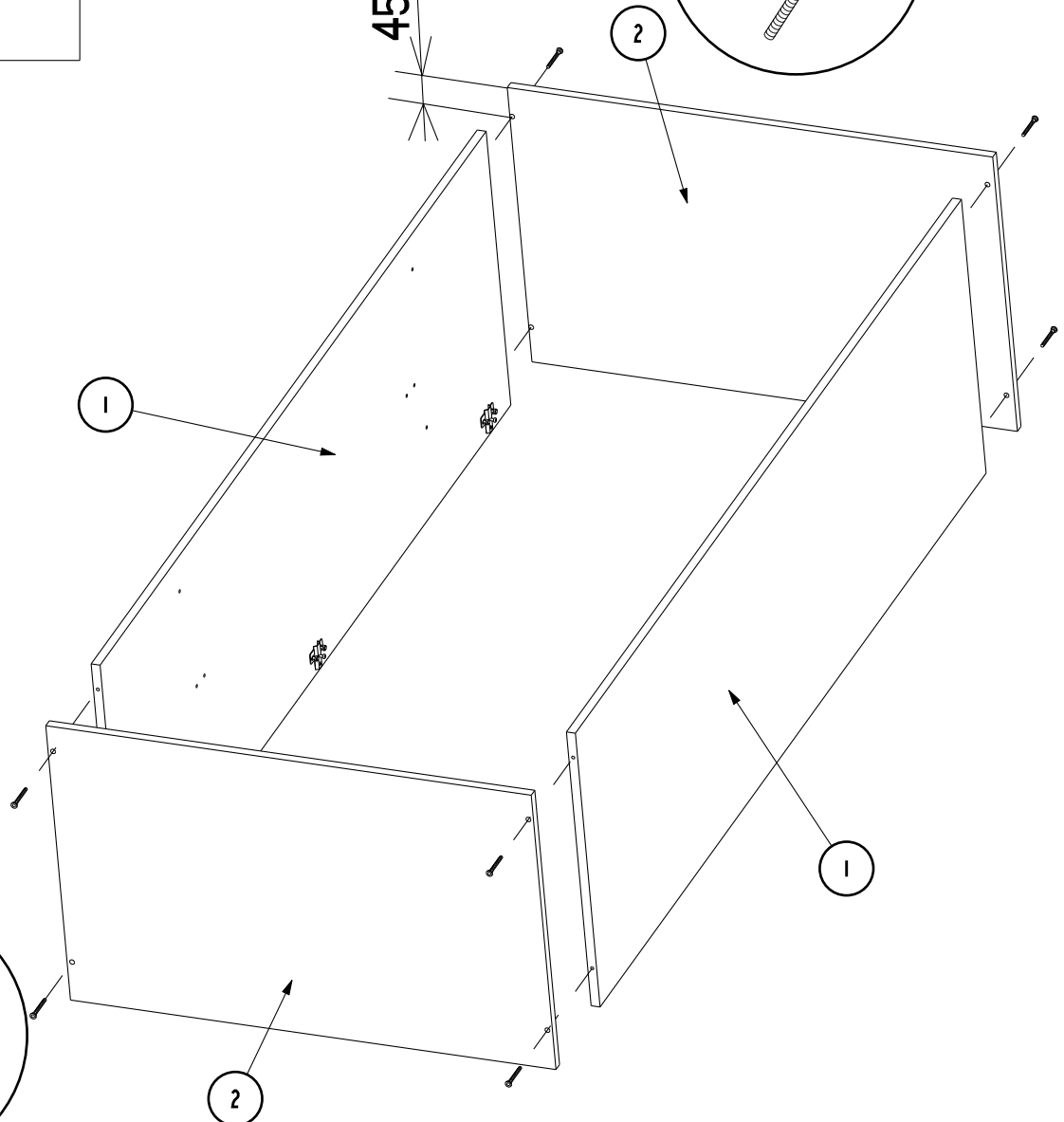
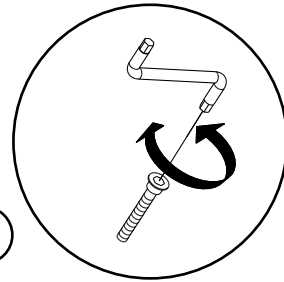

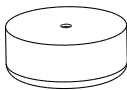

1085 0 03-Jul-09

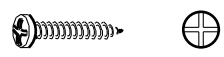
3	2707	X4
		

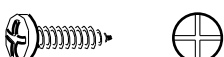
907	X2
	
VBA TR 3x16	

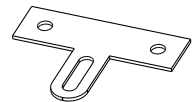
916	X4
	
VBA TR 4x13	

353005	X1
	

604757	X1
	
x30	

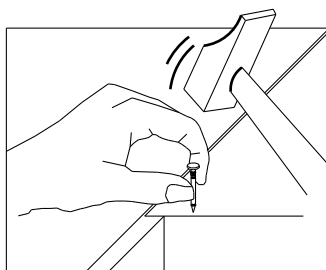
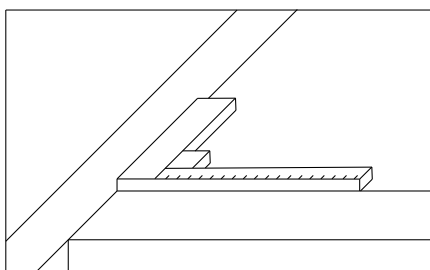
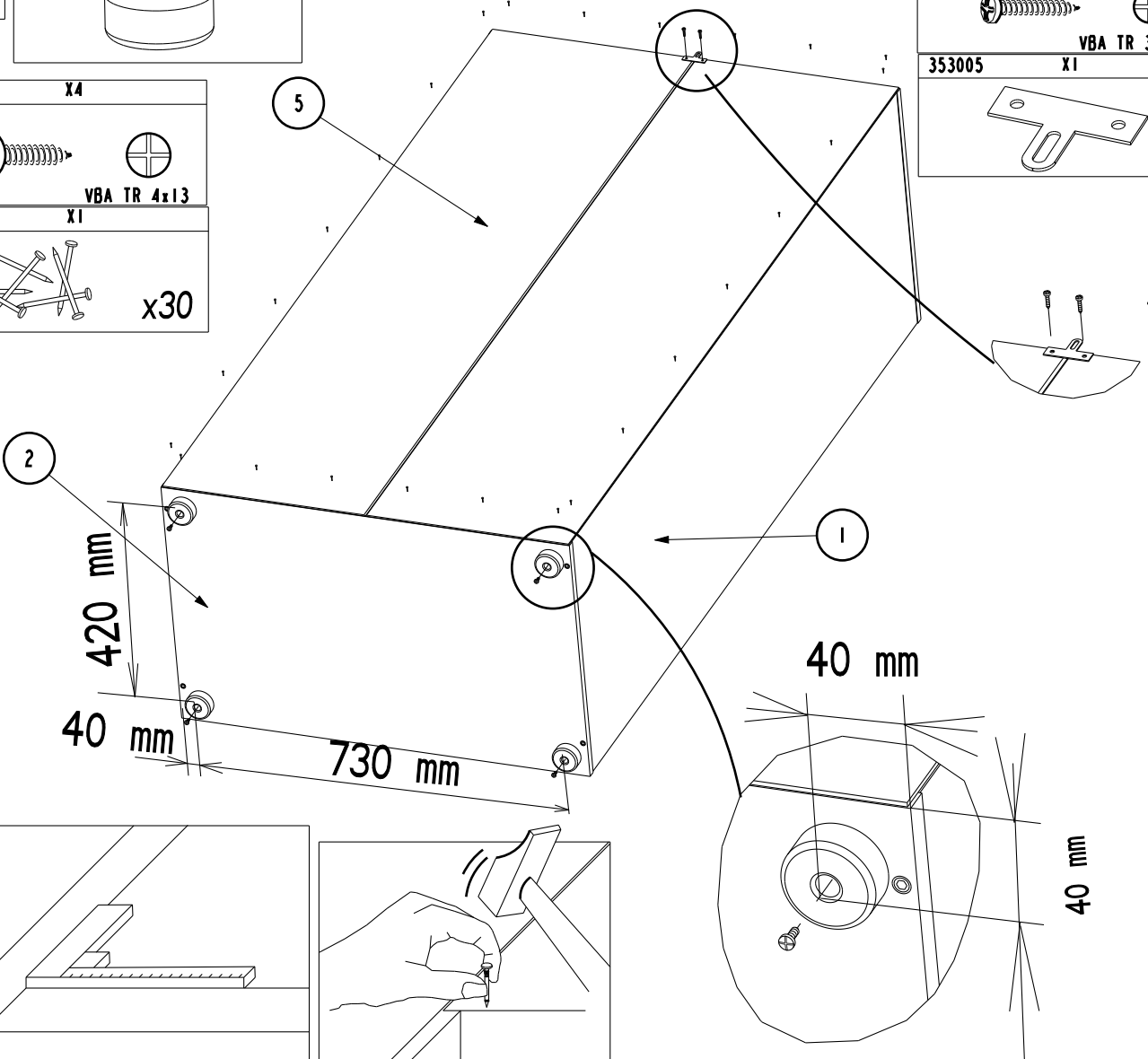

4	918	X4
		
VBA TR 4x25		

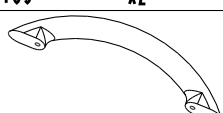
332169	X2
	

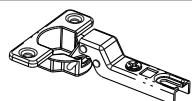
333011	X 6
	

949	X12
	
VBA TF 4x15	

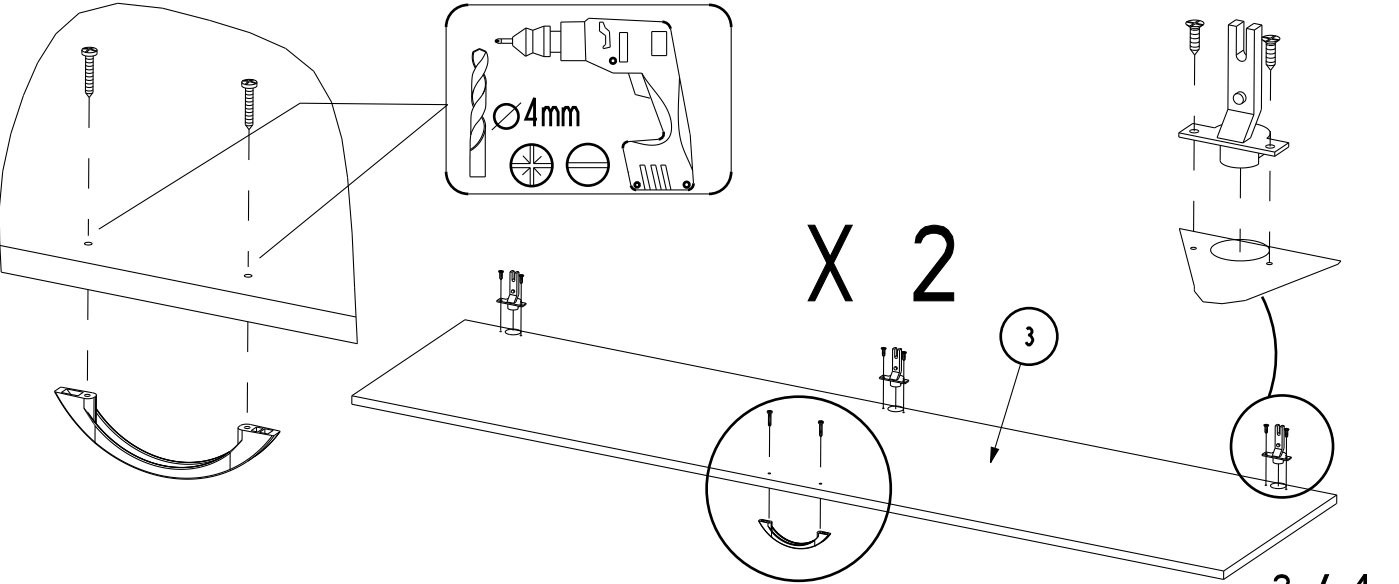

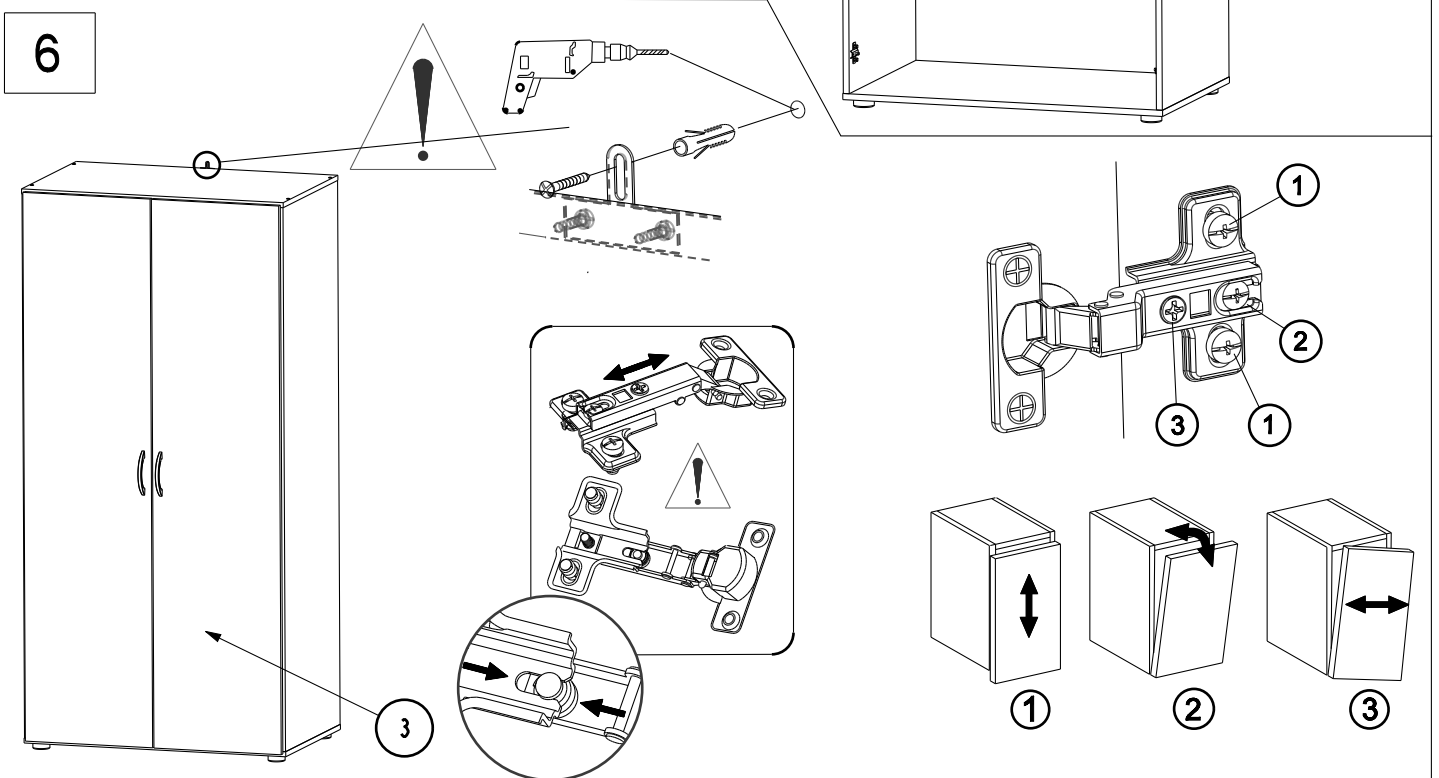
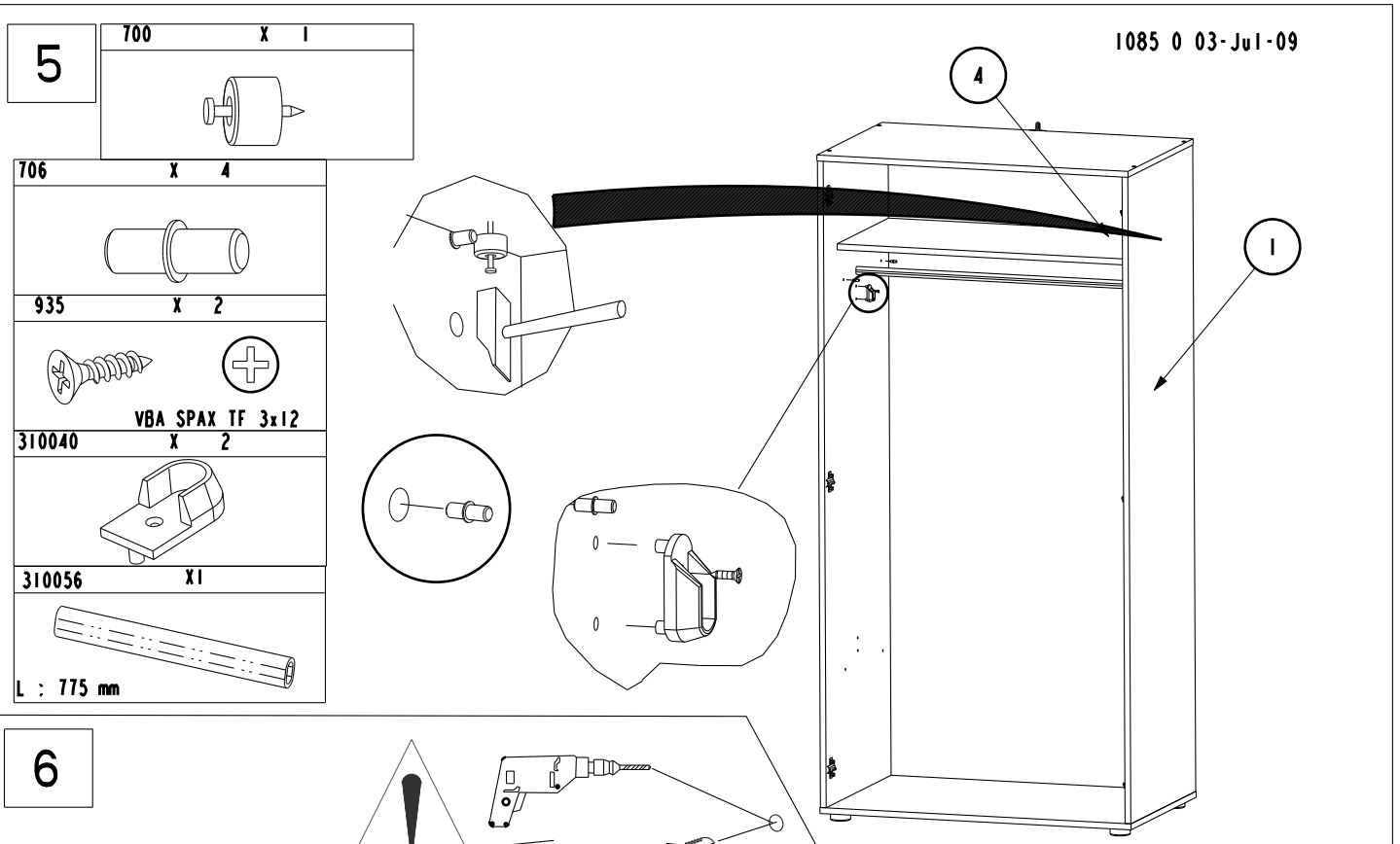

FR MEUBLES A FIXER AU MUR:
 - FIXER LE MEUBLE AU MUR AVEC LES ATTACHES PREVUES A CET EFFET
 - VERIFIER QUE LES VIS ET LES CHEVILLES UTILISEES SONT ADAPTEES AU SUPPORT

ES MUEBLES A FIJAR EN LA PARED:
 - FIJAR EL MUEBLE EN LA PARED CON LAS GRAPAS PREVISTAS
 - COMPROBAR QUE LOS TORNILLOS Y LAS CLAVIJAS UTILIZADAS SON ADAPTADAS AL SOPORTE

PT MOVEIS A FIXAR NA PAREDE:
 - FIXAR O MOVEL NA PAREDE COM OS PRENDES PREVISTOS
 - VERIFICAR QUE OS PARAFUSOS E AS CAVILHAS UTILIZADOS SAO ADAPTADOS AO SUPORTE

EN FURNITURES TO BE HOLD ON THE WALL:
 - HOLD THE FURNITURE ON THE WALL WITH THE FASTENINGS PROVIDED FOR THIS PURPOSE
 - CHECK THAT THE SCREW AND PEGS FIT WITH THE SUPPORT

IT MOBILI DA FISSARE AL MURO:
 - FISSARE IL MOBILE AL MURO CON LE FLANGIE PREVISTE A TALE SCOPO
 - VERIFICARE CHE LE VITI ED I PERNI USATI SIANO ADATTI A QUEL TIPO DI SUPPORTO

PL MEBEL PRZEZNACZONY DO ZAINSTALOWANIA NA SCIANIE:
 - NALEZY ZAMONTOWAC TEN MEBEL NA SCIANIE PRZEZNACZONYM DO TEGO CELU UCHWYTAMI
 - NALEZY SPRAWDZIC CZY SRUBY I KOSZULKI SA ODPOWIEDNIEJ WIELKOSCI W STOSUNKU DO UCHWYTOW

DE MOEBEL AN DER MAUER ZU BEFESTIGEN:
 - BEFESTIGEN SIE DAS MOEBELSTUECK MIT DEN DAFUER VORGESEHENEN BEFESTIGUNGSHAKEN
 - UEBERPRUEFEN SIE BITTE DASS DIE SCHRAUBEN UND DUEBEL MIT DEM MATERIAL DER MAUER UEBEREINSTIMMEN

NL MEUBELS DIE AAN DE MUUR GEFIXEERD MOETEN WORDEN:
 - FIXEER HET MEUBEL AAN DE MUUR MET DE DAARVOOR BESTENDE HAKEN
 - VERFIEER OF DE GEBRUIKTE SCHROEVEN BIJ DE BEVESTIGINGSHAAK HOREN