

SAV  
SPAREPARTS  
KUNDEDIENST  
POS VENTAS  
SERVICE NA VERKOOP  
SERVIZIO POST-VENDITA  
SERVICO DEPOIS DE VENDA  
SERWIS POGWARANCY JNY

3325-02  
**BUSSY**

### IMPORTANT

- A- Prduit conforme aux exigences de securite "NF EN 747 1/2 2012"
- B- Le couchage en hauteur ne convient pas aux enfants de moins de six ans en raison des risques de blessures dues aux chutes
- C- Il est conseillé de ne pas laisser les enfants jouer sur les lits superposés.
- D- Pour des raisons de sécurité la hauteur maximale du matelas du haut ne doit pas dépasser la marque apposée sur le montant supérieur.
- E- Vérifier 15 jours après la première utilisation et ensuite périodiquement que les barres de protection, échelle et autres éléments sont correctement placés, dans un bon état et que toutes les vis sont bien serrées.
- F- Le lit ne doit pas être utilisé lorsqu'une partie de la structure manque ou est cassée. Les pieces de rechanges peuvent être obtenues auprès de votre détaillant
- G- Attention aux risques d'étranglement avec des objets fixés sur le lit, tels que des cordes, des harnais, des ficelles ou des ceintures.

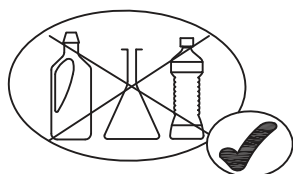

**90x190cm**  
(Option 1)

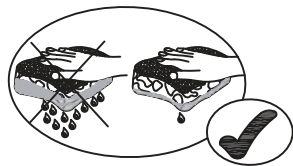
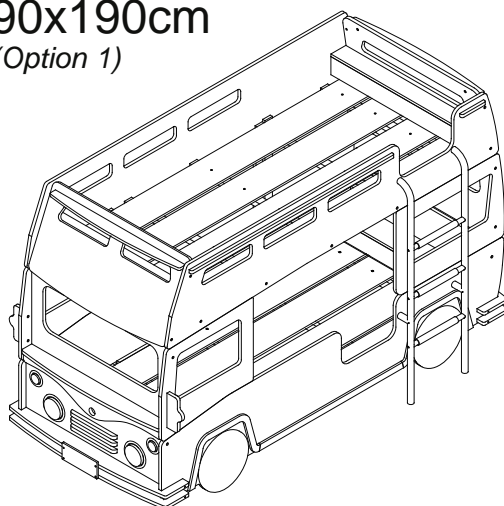
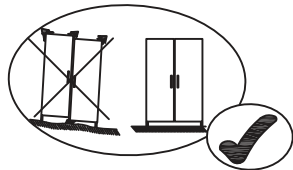

**90x200cm**  
(Option 2)

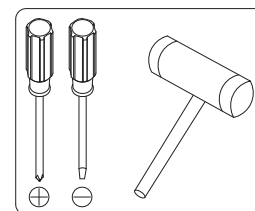
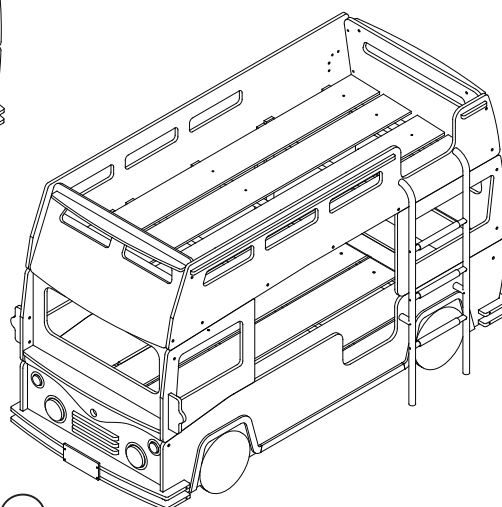

**FR SECURITE**

RESPECTER LES INSTRUCTIONS DE MONTAGE DECRITES DANS LA NOTICE

**EN CAUTION**

FOLLOW CAREFULLY THE ASSEMBLING INSTRUCTIONS DESCRIBED IN THE DIRECTIONS

**DE SICHERHEITSVORSCHRIFTEN**

BEACHTEN SIE BITTE UNBEDINGT DIE ANGEGBENEN AUFBAUVORSCHRIFTEN

**ES SEGURIDAD**

RESPECTAR LAS INSTRUCCIONES DE MONTAJE DESCRIBIDAS EN EL FOLLETO

**NL VEILIGHEID**

DE IN DE GEBRUIKSAANWIJZING BESCHREVEN INSTRUCTIE RESPECTEREN

**IT SICUREZZA**

RISPETTARE LE INSTRUZIONI DI MONTAGGIO DESCRITTE NEEL'AVVERTENZA

**PT SEGURANCA**

RESPECTAR AS INSTURAÇOS DE MONTAGEH DESCREVEDAS NA INSTRUÇOES DE USO

**PL UWAGA**

PROSZĘ PRZESTRZEGAĆ INSTRUCJI MONTAŻU

**Meuble à usage domestique / House furniture / Nur zum Hauslichem Gebrauch / Mueble a uso domestico  
Meubel voor eigen gebruik / Mobile per abitazione / Mueble a uso domestico / Mebel Domowego**

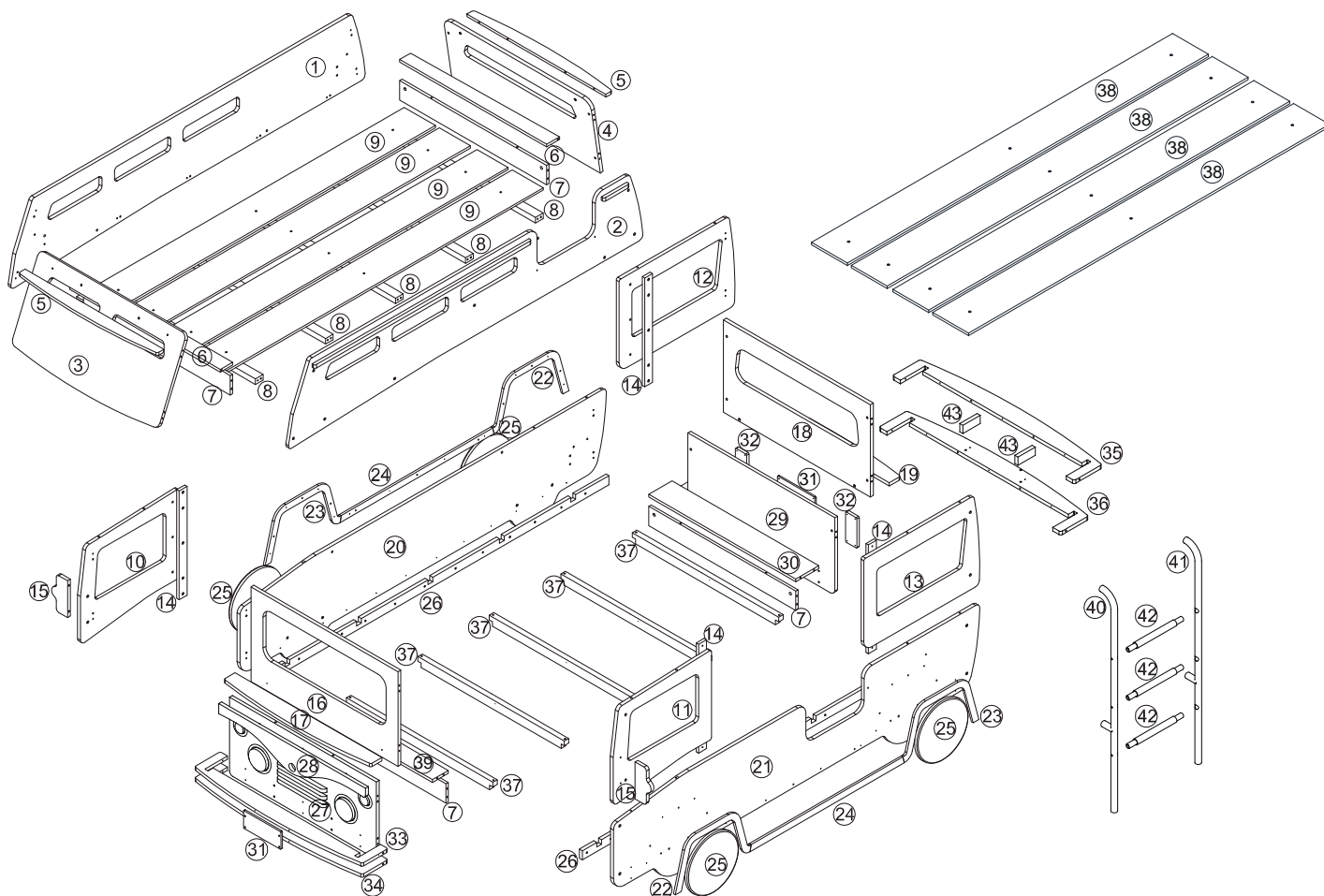

①	x1	222.4x43x3.6cm
②	x1	222.4x43x3.6cm
③	x1	92x48x1.8cm
④	x1	92x41.8x1.8cm
⑤	x2	87x7x1.8cm
⑥	x2	92x5x1.5cm
⑦	x4	92x12x1.5cm
⑧	x5	92x4.8x3cm
⑨	x4	208x20x1.2cm
⑩	x1	53.5x61.5x1.8cm
⑪	x1	53.5x61.5x1.8cm

⑫	x1	72.5x50.2x1.8cm
⑬	x1	72.5x50.2x1.8cm
⑭	x4	59x4x1.5cm
⑮	x2	20x8.5x1.8cm
⑯	x1	92x51.2x1.8cm
⑰	x1	92x10.3x1.8cm
⑱	x1	92x50x1.8cm
⑲	x1	92x7x1.8cm
⑳	x1	230x51.8x1.8cm
㉑	x1	230x51.8x1.8cm
㉒	x2	48x26.7x1.2cm

㉓	x2	48x26.7x1.2cm
㉔	x2	97x3.5x1.2cm
㉕	x4	∅32x1.8cm
㉖	x2	210x5x1.8cm
㉗	x1	92x41.8x3.3cm
㉘	x1	92x15x1.8cm
㉙	x1	92x41.8x1.8cm
㉚	x1	92x14.5x1.5cm
㉛	x2	23.4x9.6x1.2cm
㉜	x2	16.5x7x1.5cm
㉝	x1	105x20x1.8cm

㉞	x1	105x20x1.8cm
㉟	x1	105x20x1.8cm
㊱	x1	105x20x1.8cm
㊲	x5	92x4.8x3cm
㊳	x4	201.5x20x1.2cm
㊴	x1	92x10x1.5cm
㊵	x1	120x∅3.2cm
㊶	x1	120x∅3.2cm
㊷	x3	36.2x∅3.2cm
㊸	x2	10x4.1x1.8cm

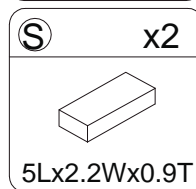
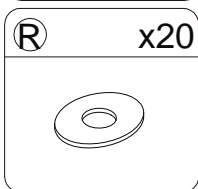
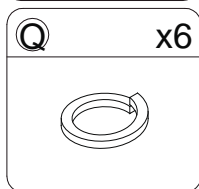
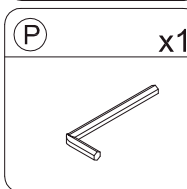
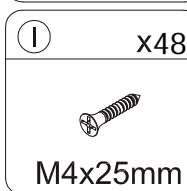
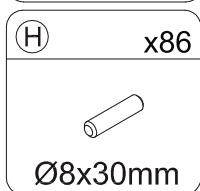
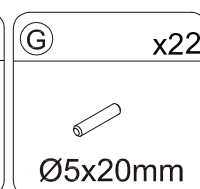
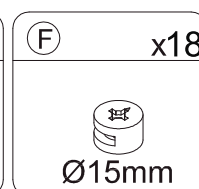
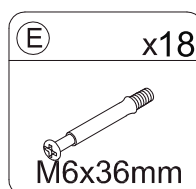
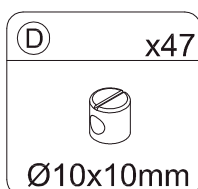
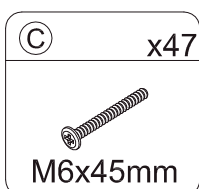
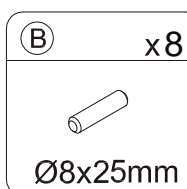
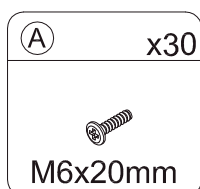

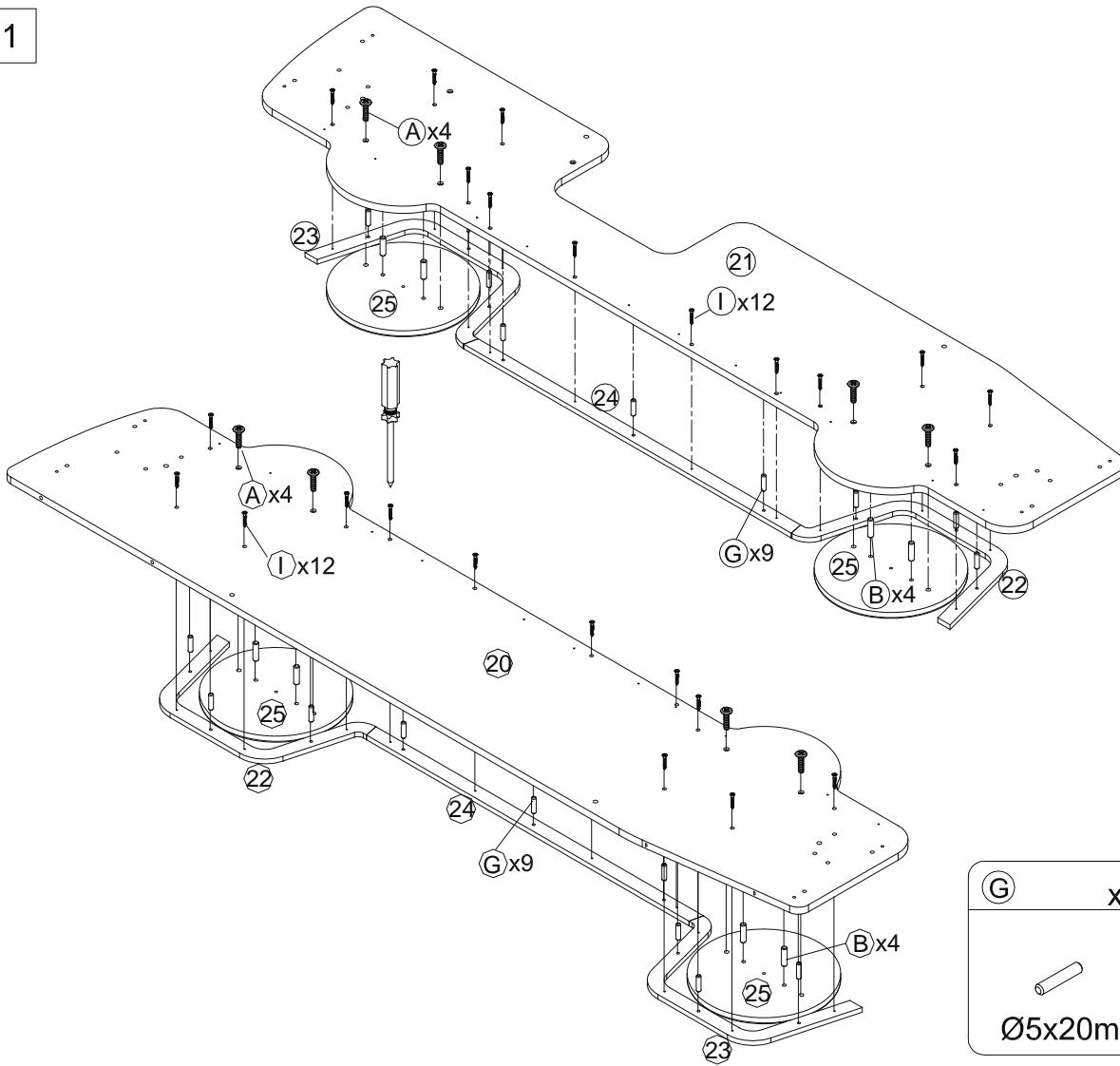

1



<b>A</b>	x8
	
M6x20mm	

<b>I</b>	x24
	
M4x25mm	

<b>G</b>	x18
	
Ø5x20mm	

<b>B</b>	x8
	
Ø8x25mm	

2

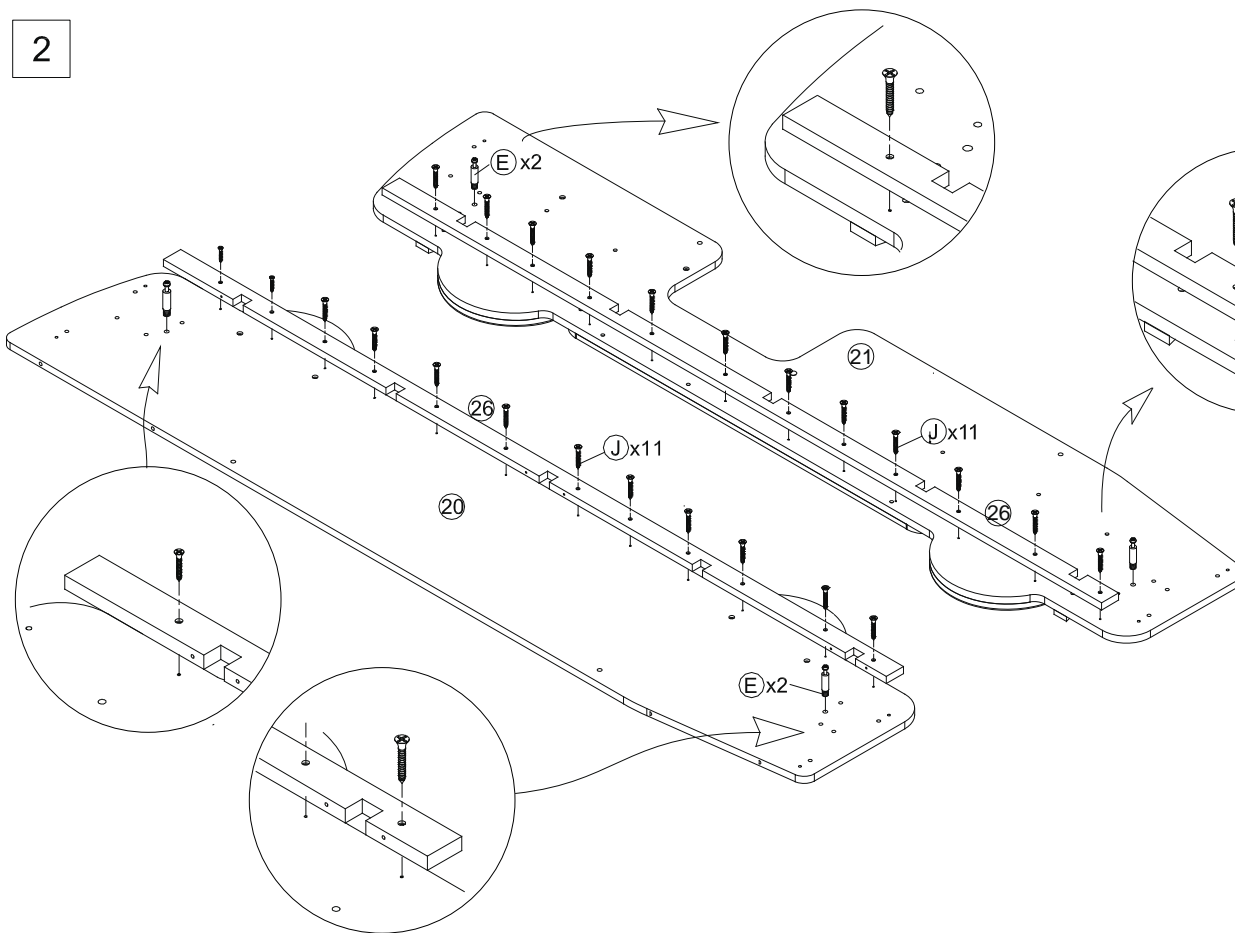

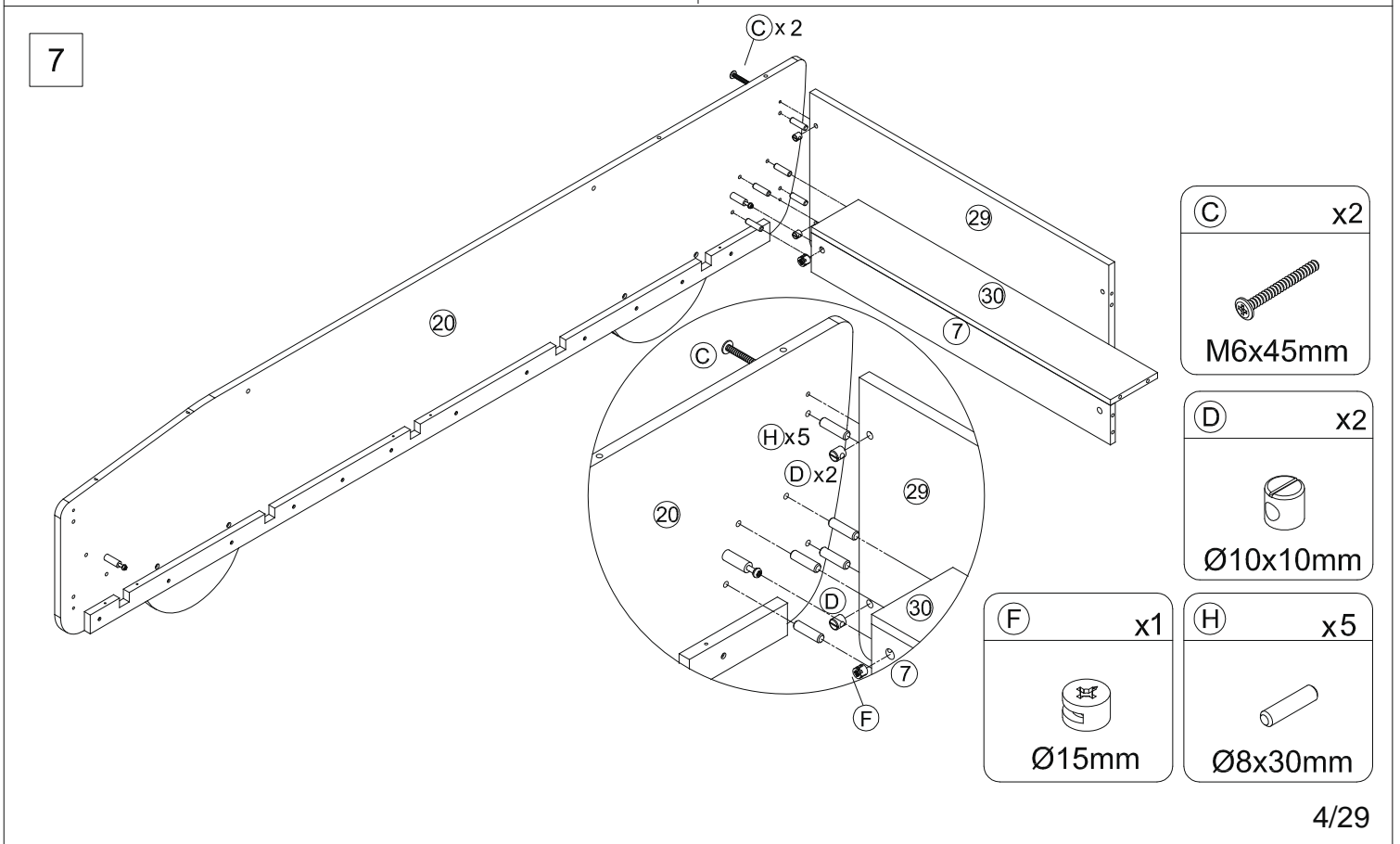
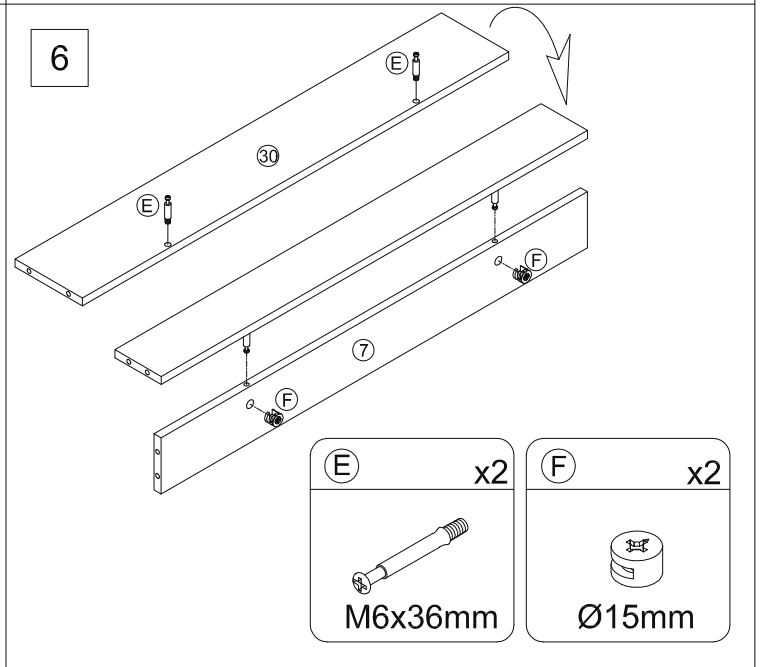
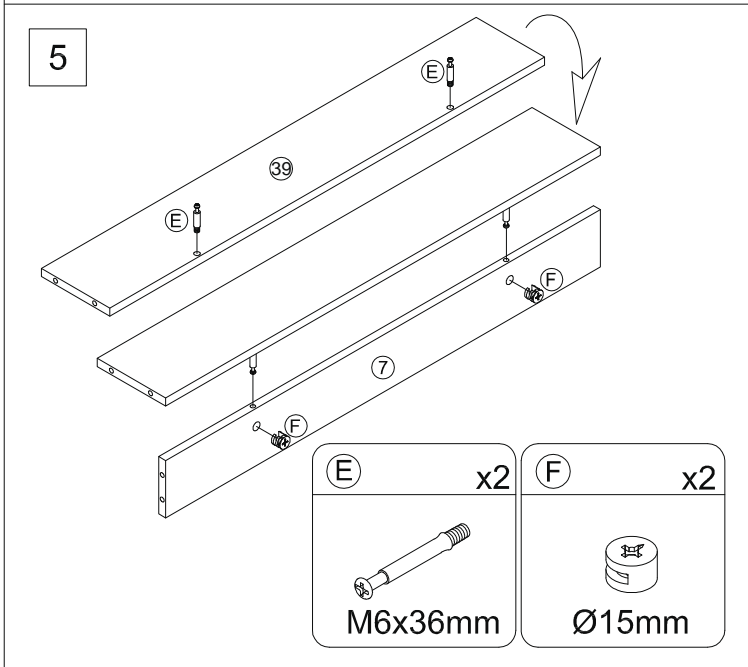
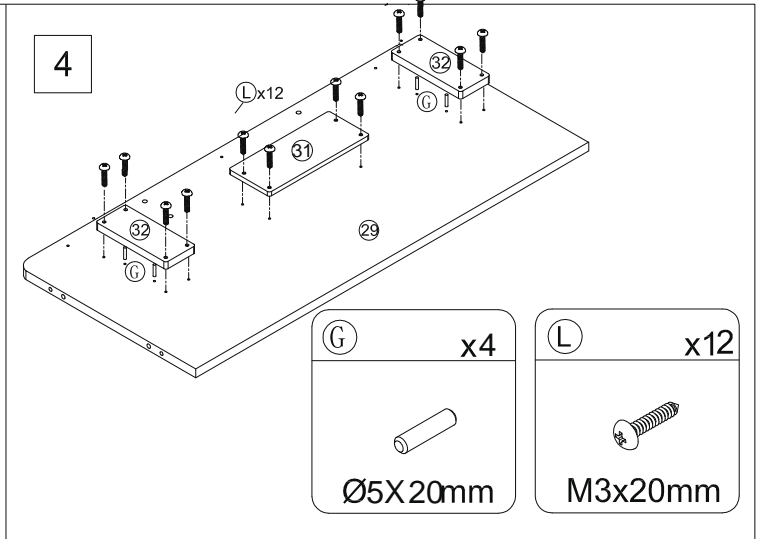
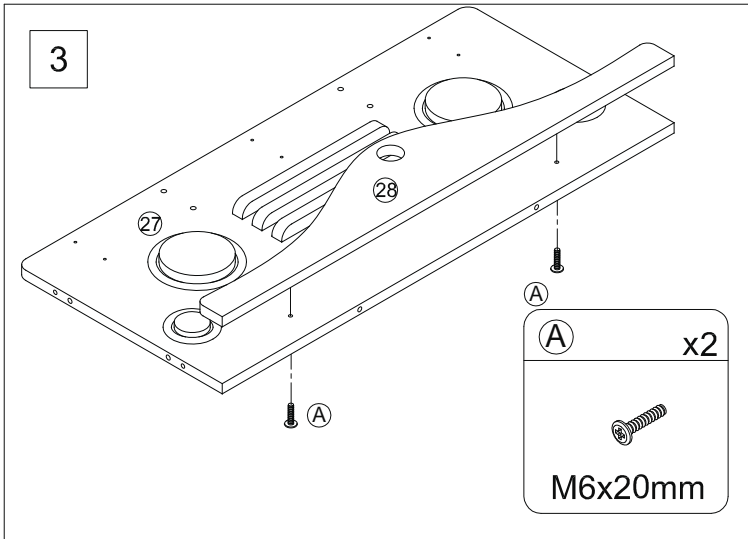

<b>E</b>	x4
	
M6x36mm	

<b>J</b>	x24
	
M4x30mm	



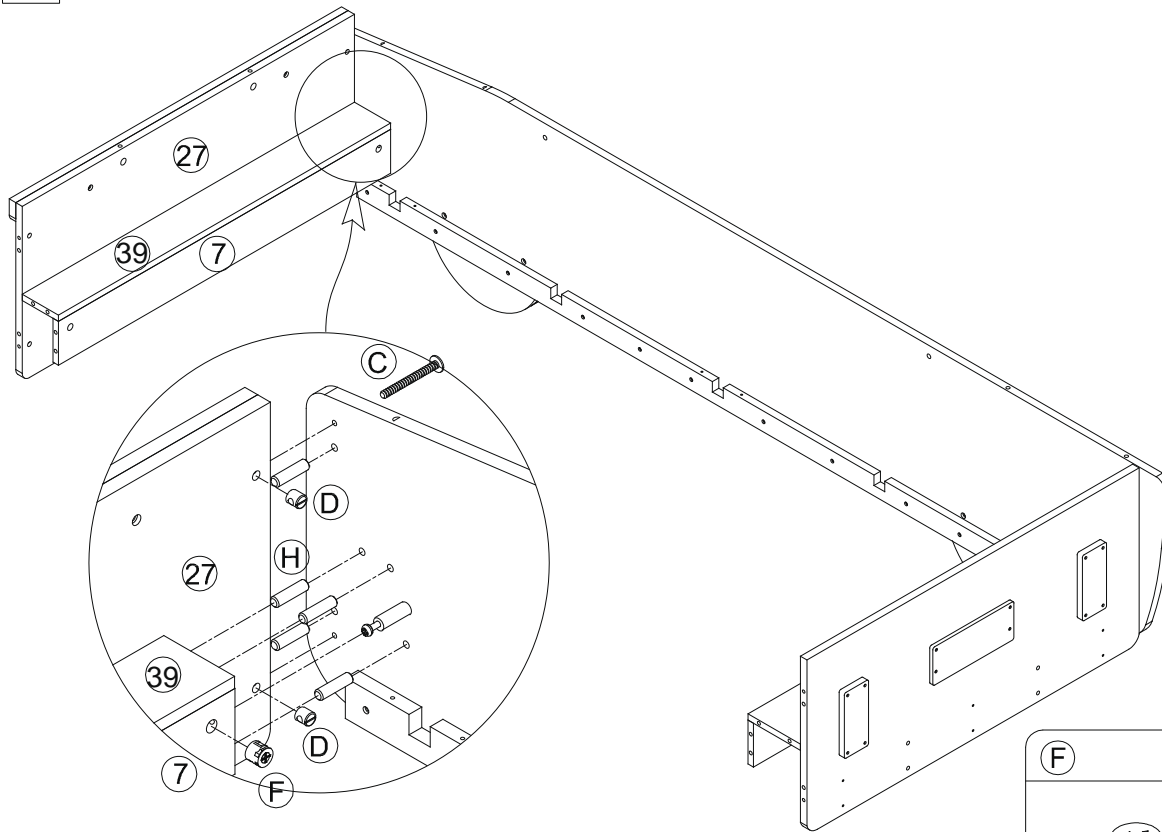

8



(C)	x2
	
M6x45mm	

(D)	x2
	
Ø10x10mm	

(F)	x1
	
Ø15mm	

(H)	x5
	
Ø8x30mm	

9

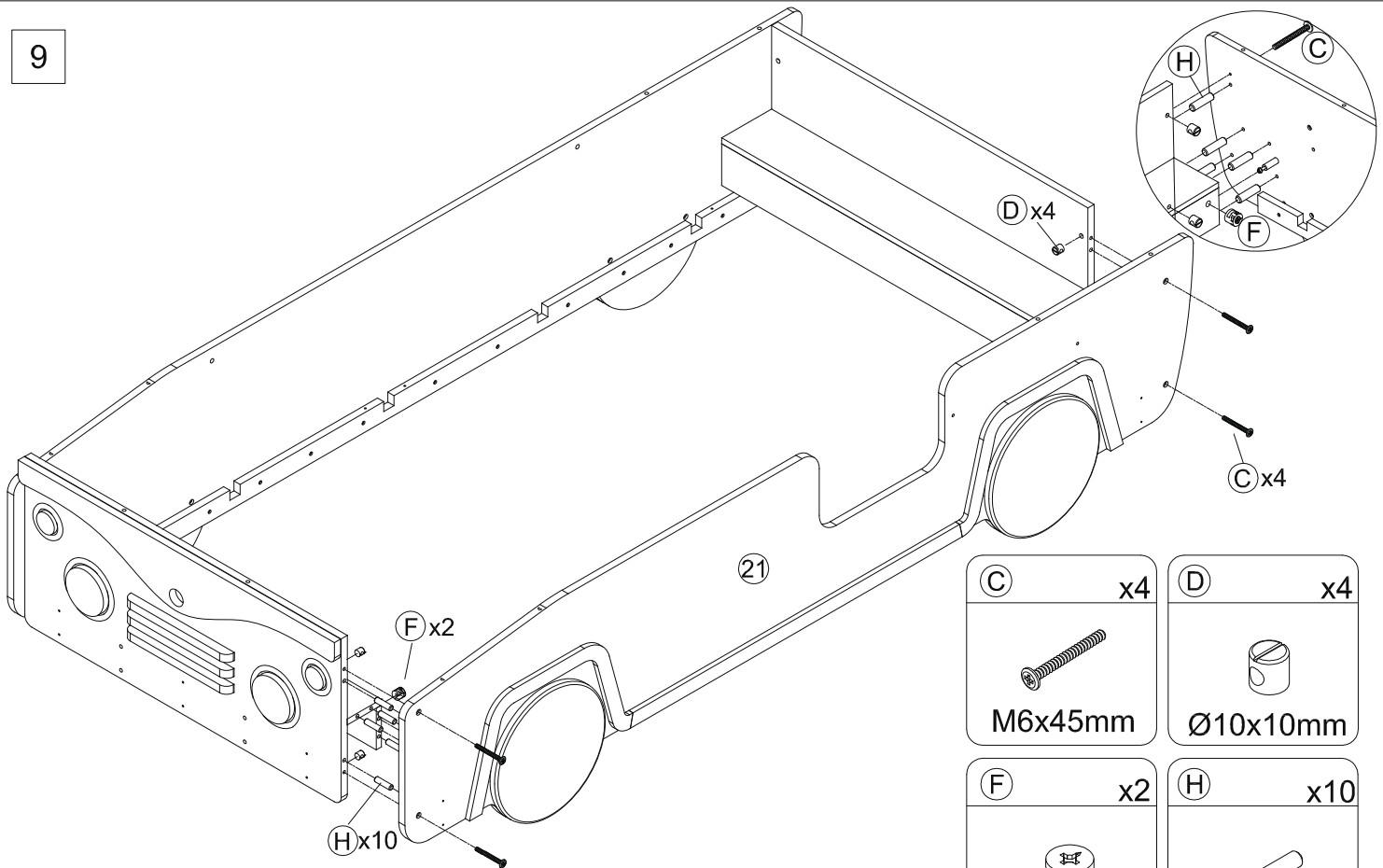

(C)	x4
	
M6x45mm	

(D)	x4
	
Ø10x10mm	

(F)	x2
	
Ø15mm	

(H)	x10
	
Ø8x30mm	

10

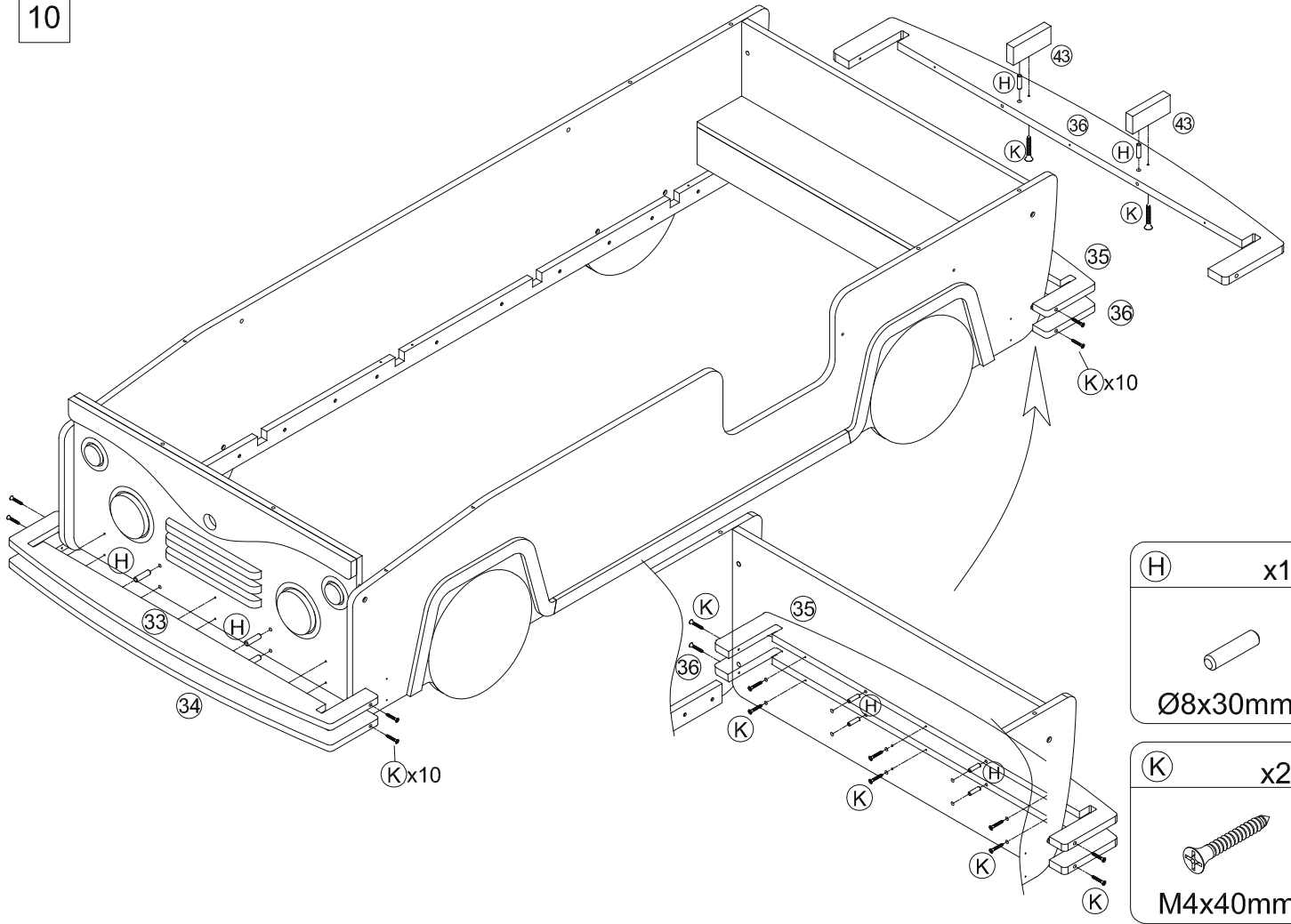

- (H) x10  
Ø8x30mm
- (K) x22  
M4x40mm

11

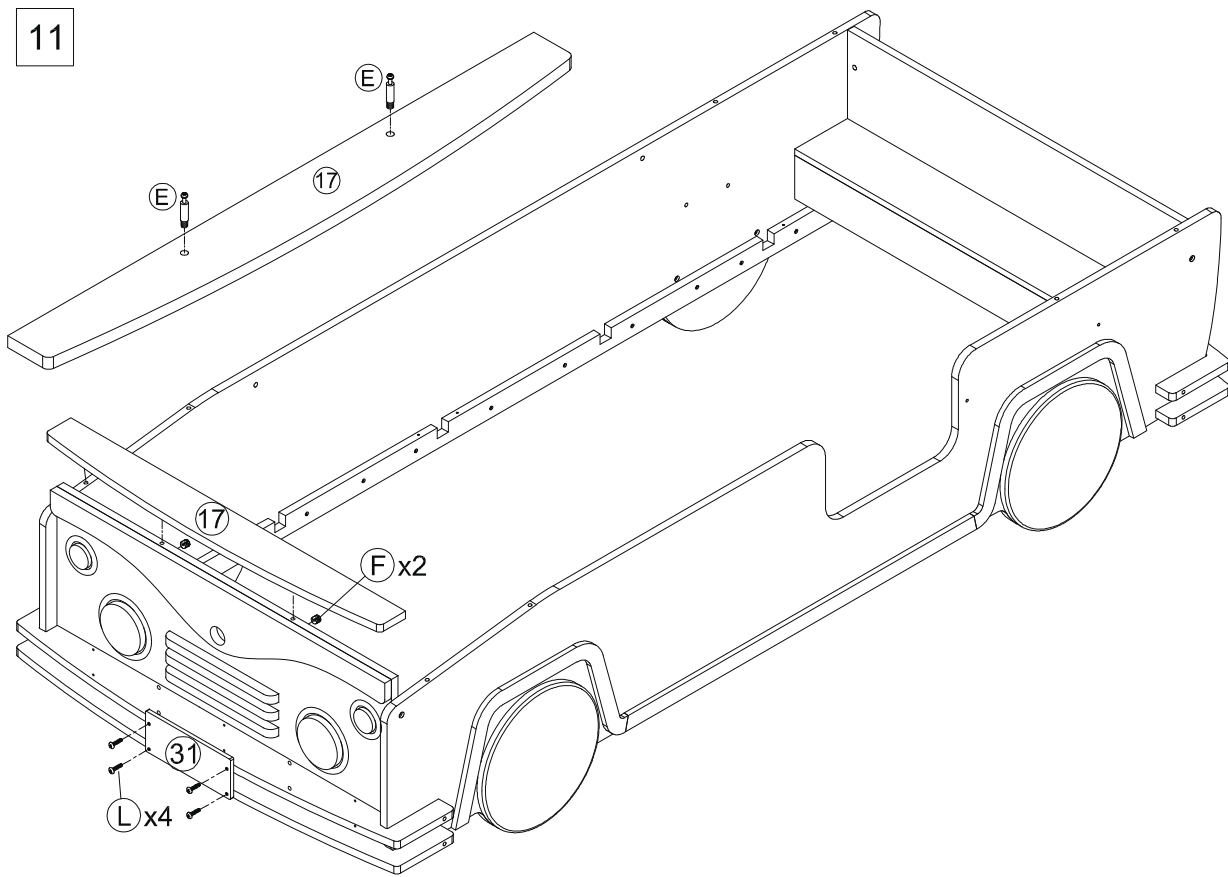

- (E) x2  
M6x36mm
- (F) x2  
Ø15mm
- (L) x4  
M3x20mm

12

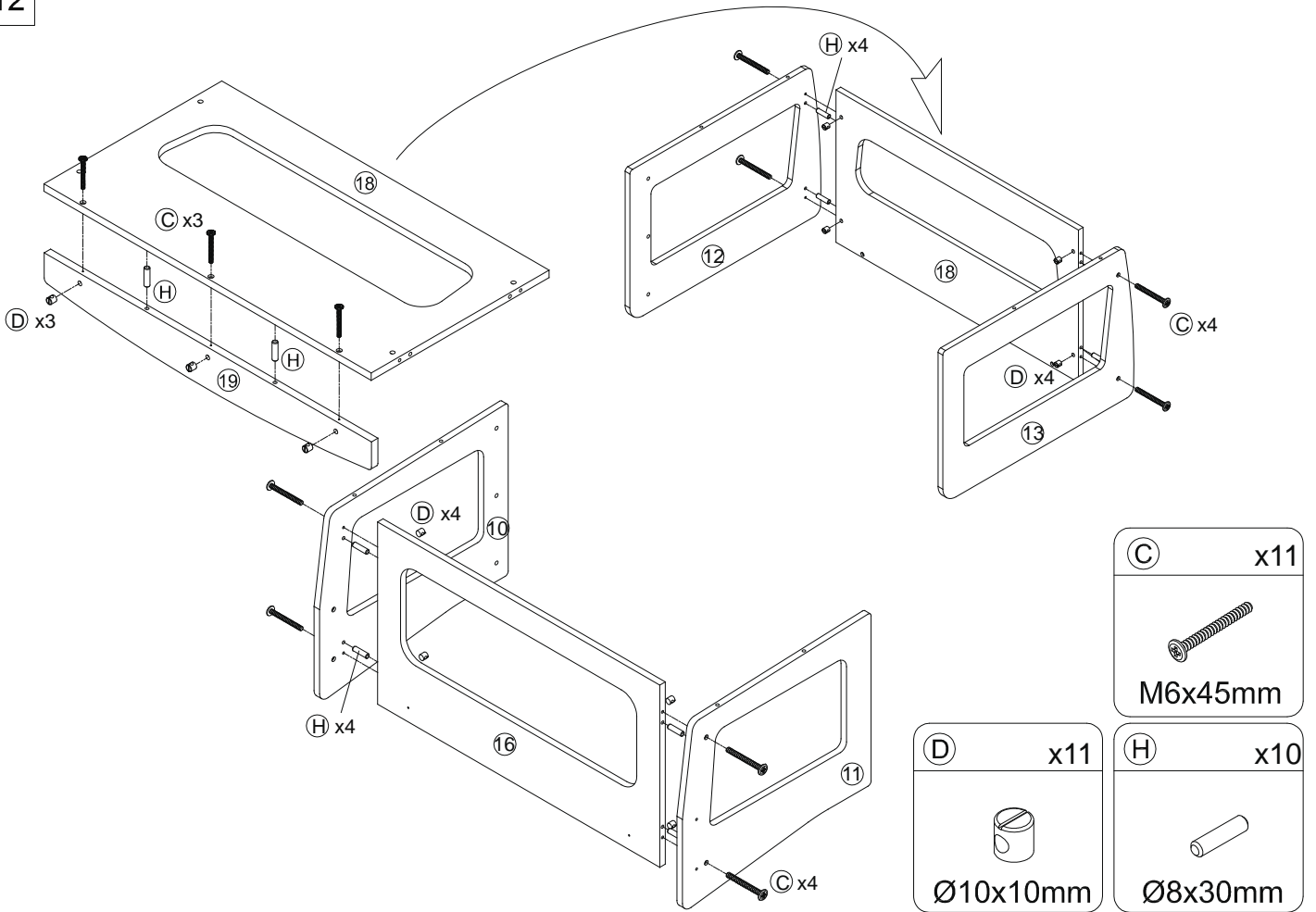

13

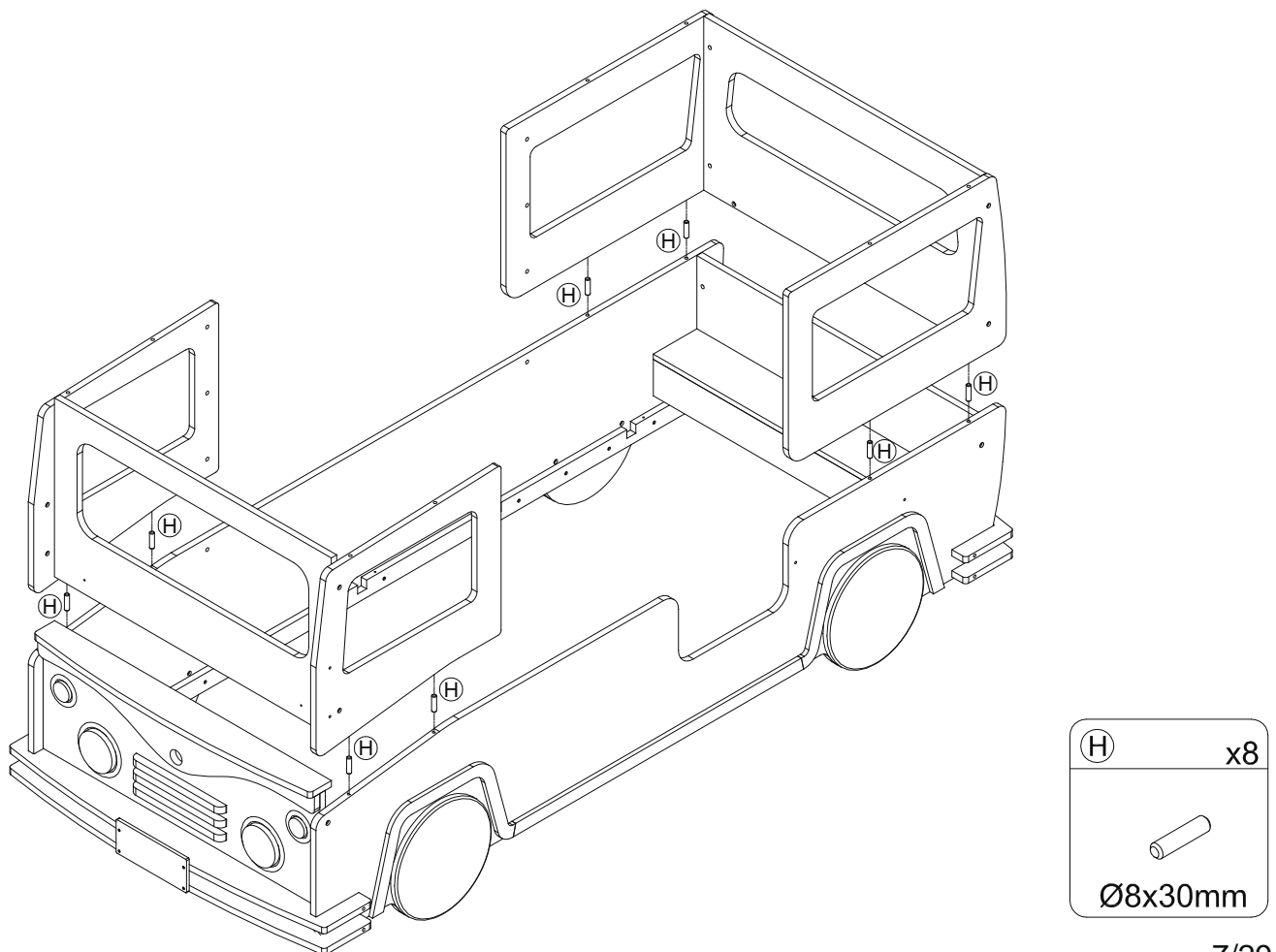

14

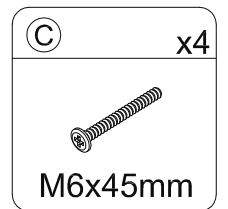
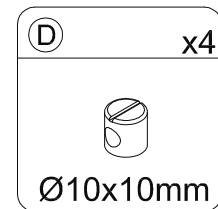
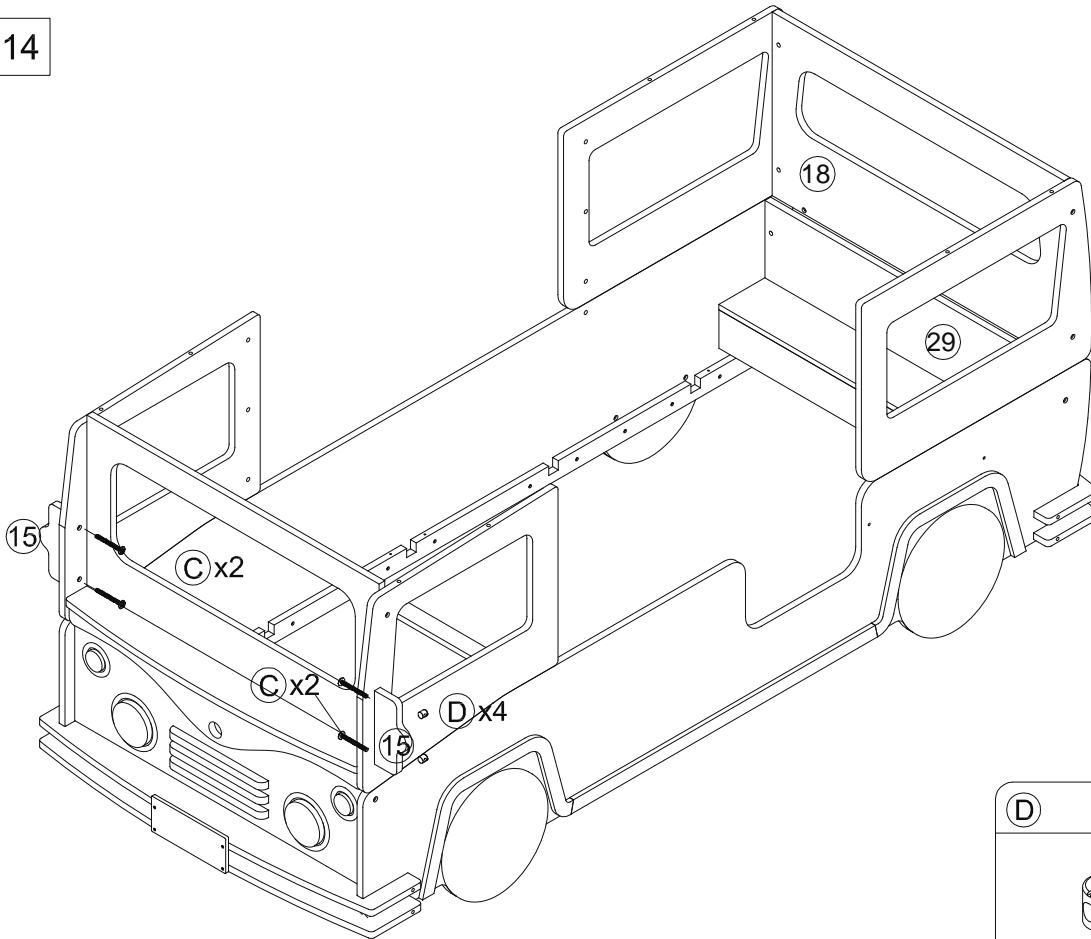

15

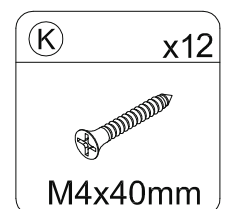
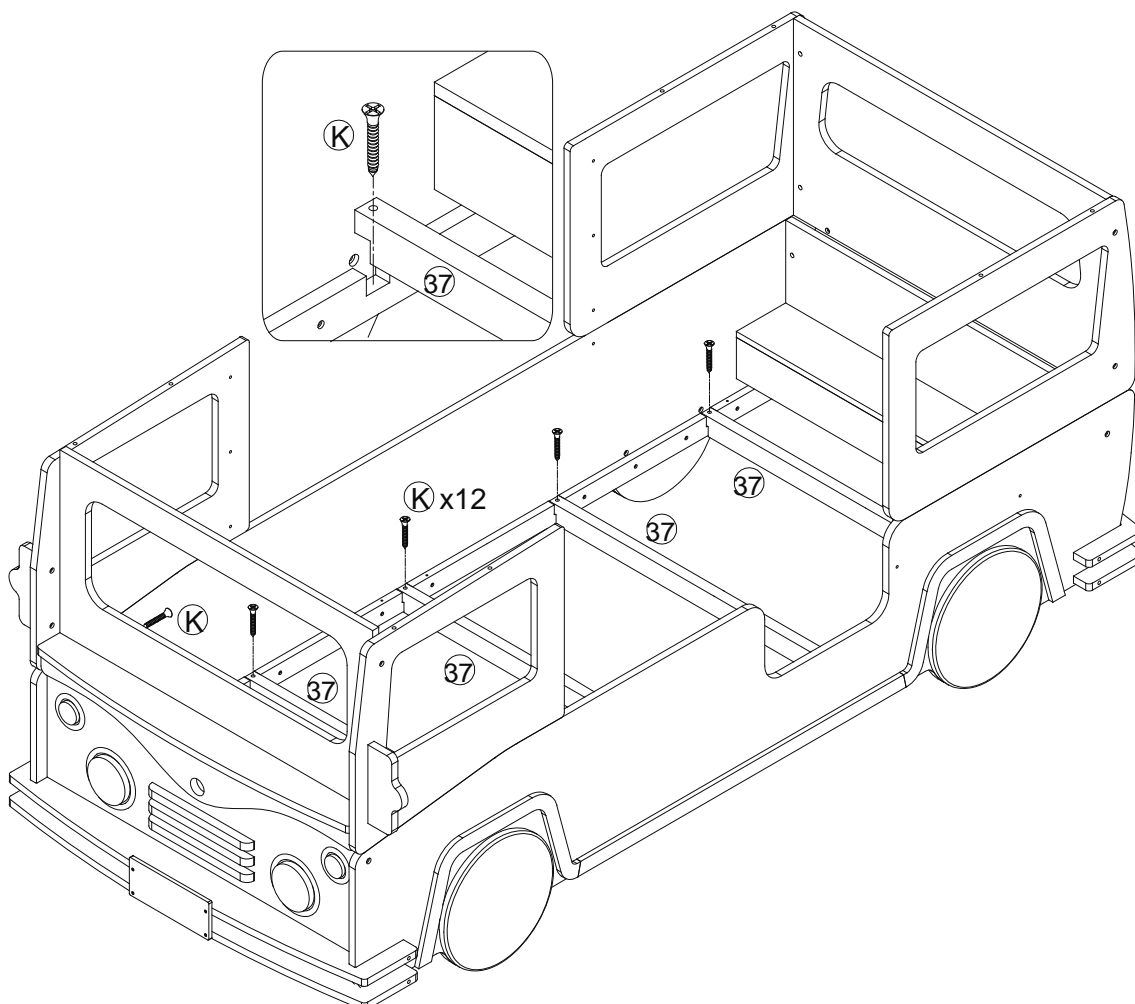



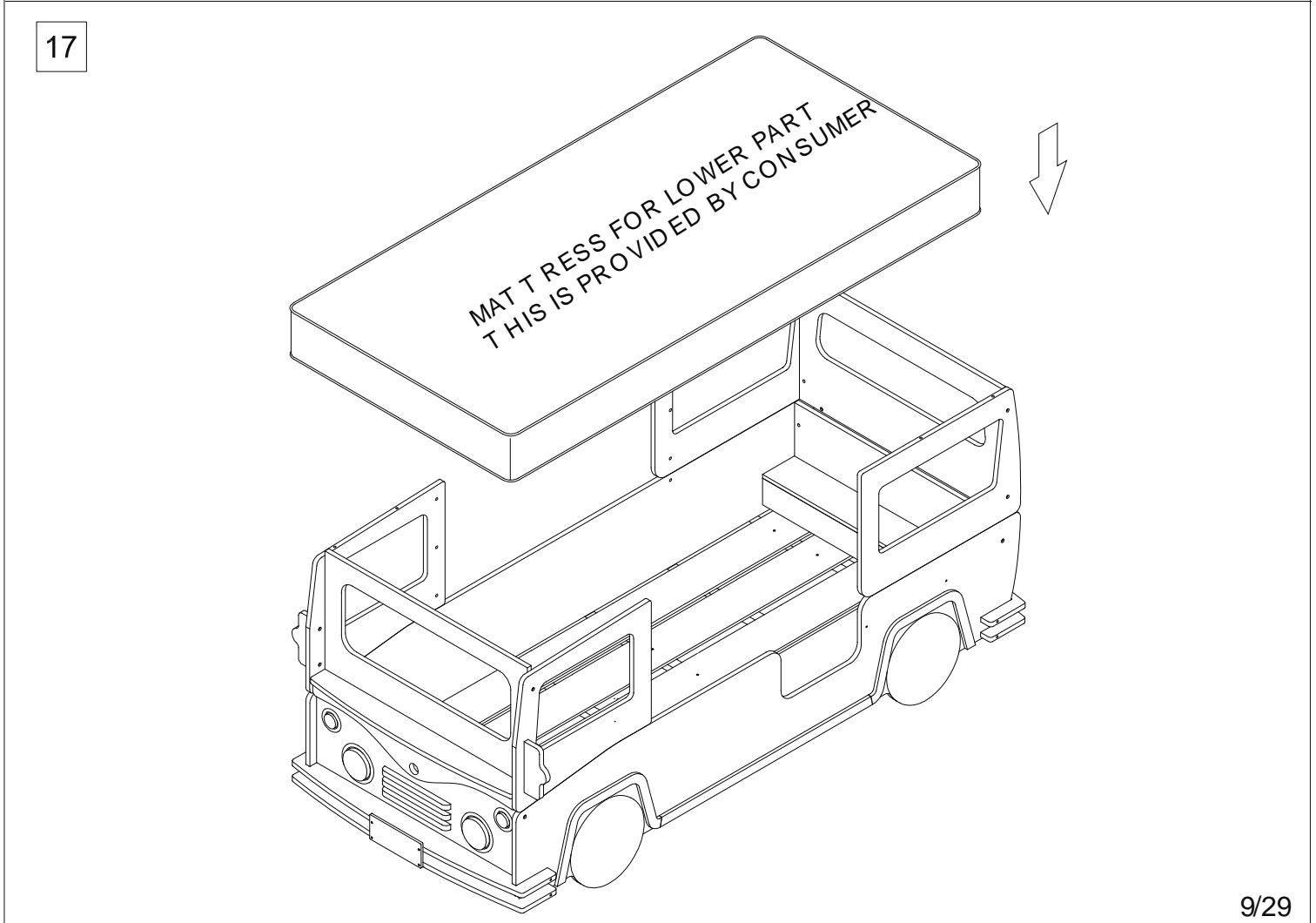
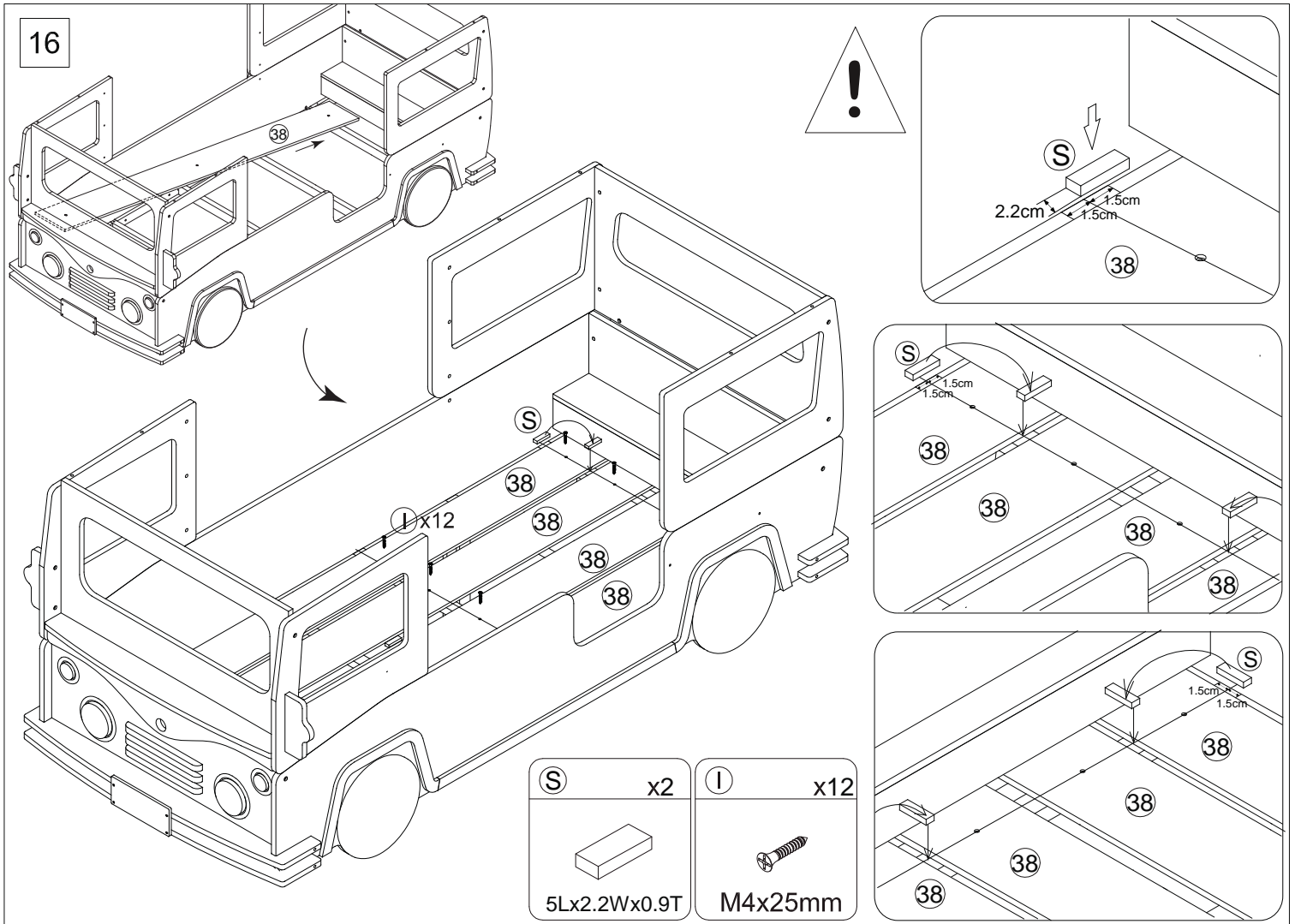

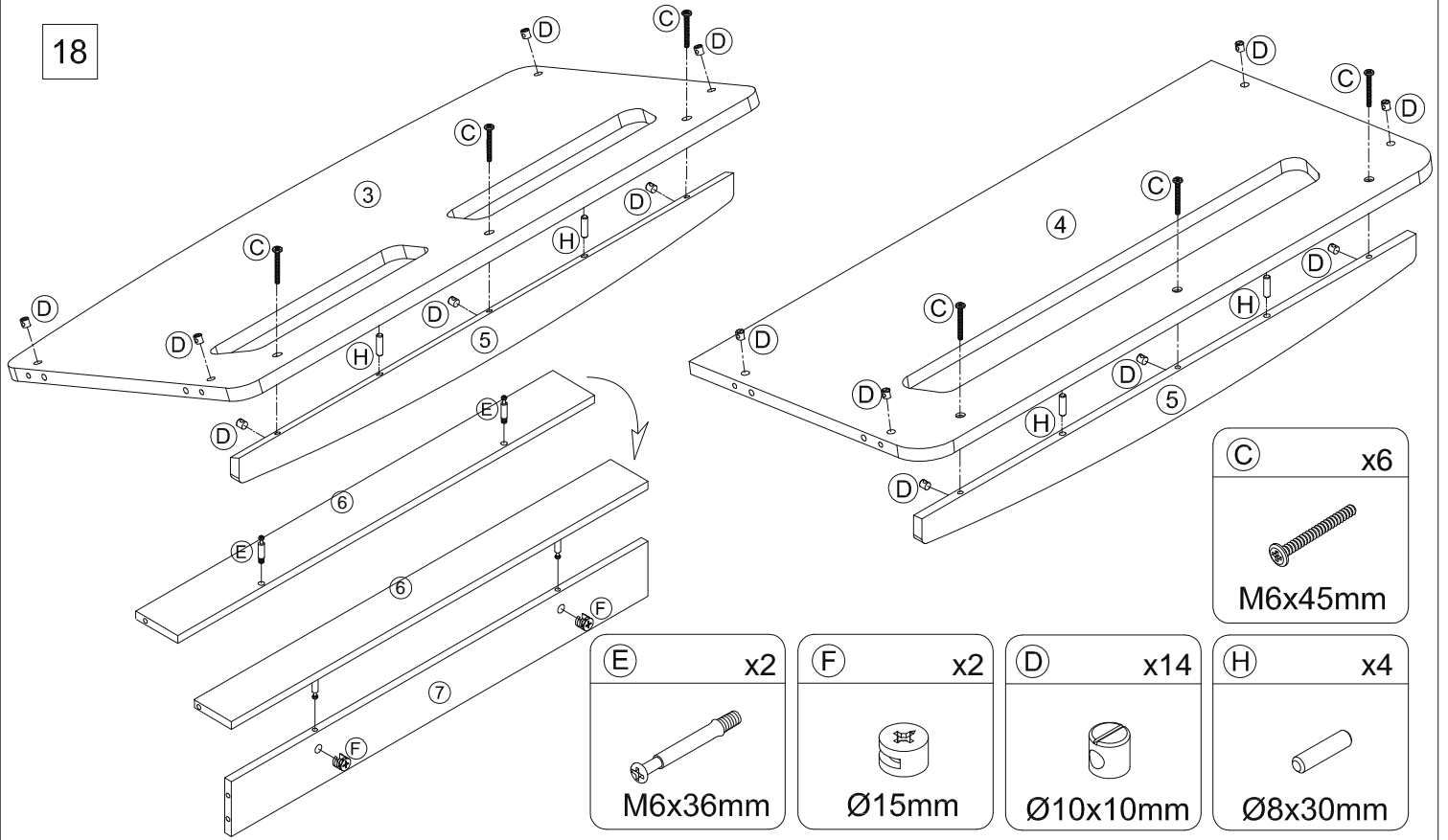

18



(C)	x6
	M6x45mm

(E)	x2
	M6x36mm

(F)	x2
	Ø15mm

(D)	x14
	Ø10x10mm

(H)	x4
	Ø8x30mm

19

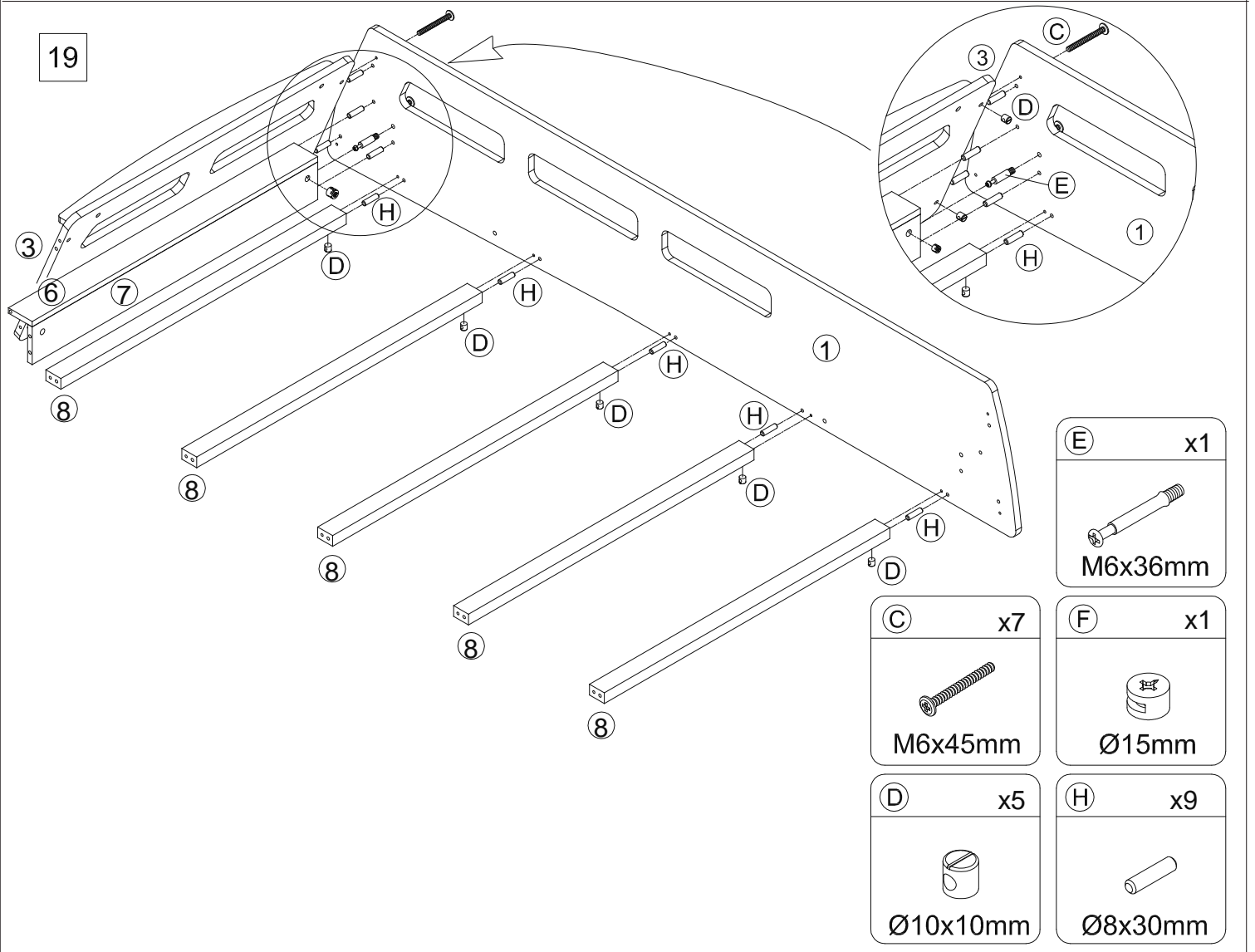

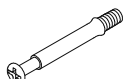
(E)	x1
	M6x36mm

(C)	x7
	M6x45mm

(F)	x1
	Ø15mm

(D)	x5
	Ø10x10mm

(H)	x9
	Ø8x30mm

20

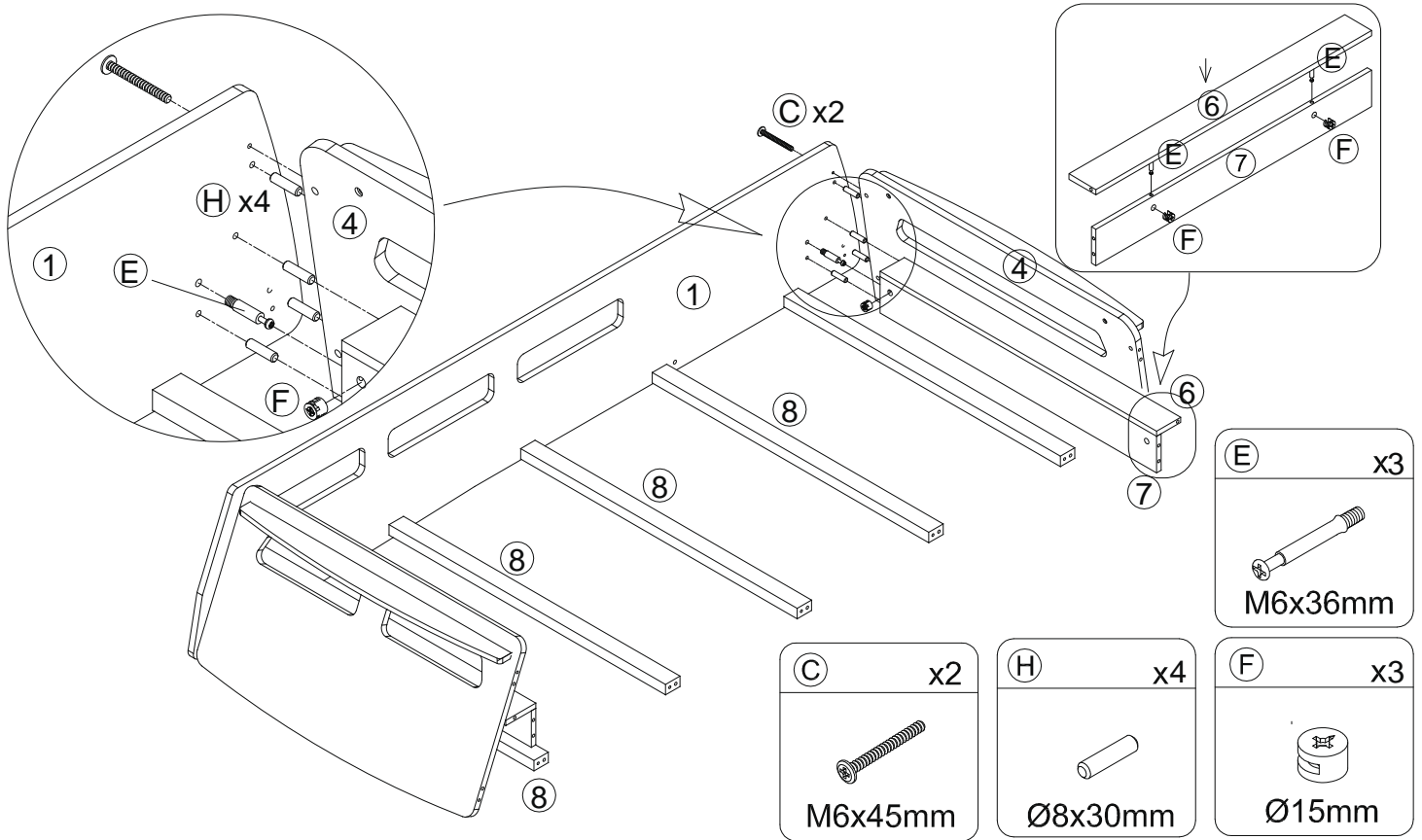

21

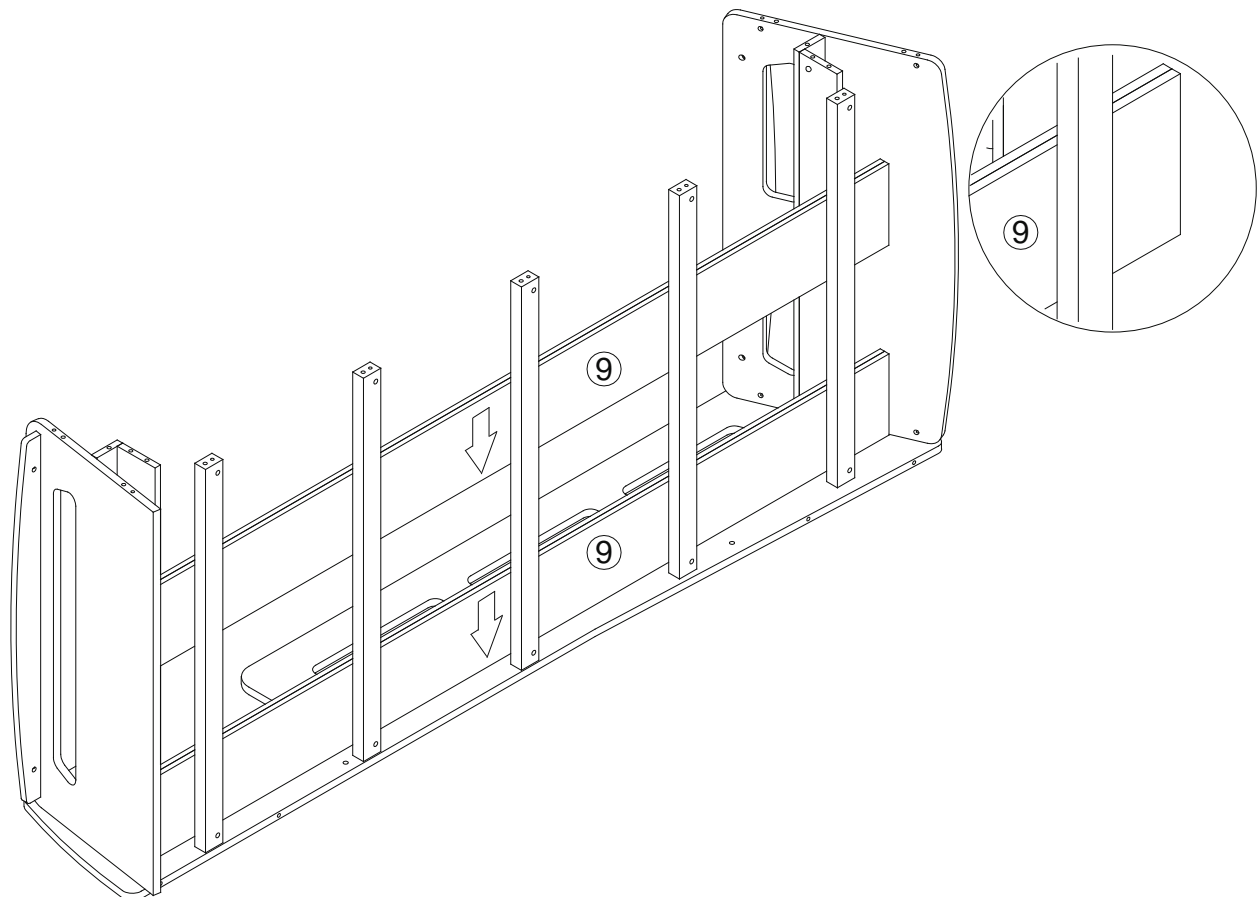

22

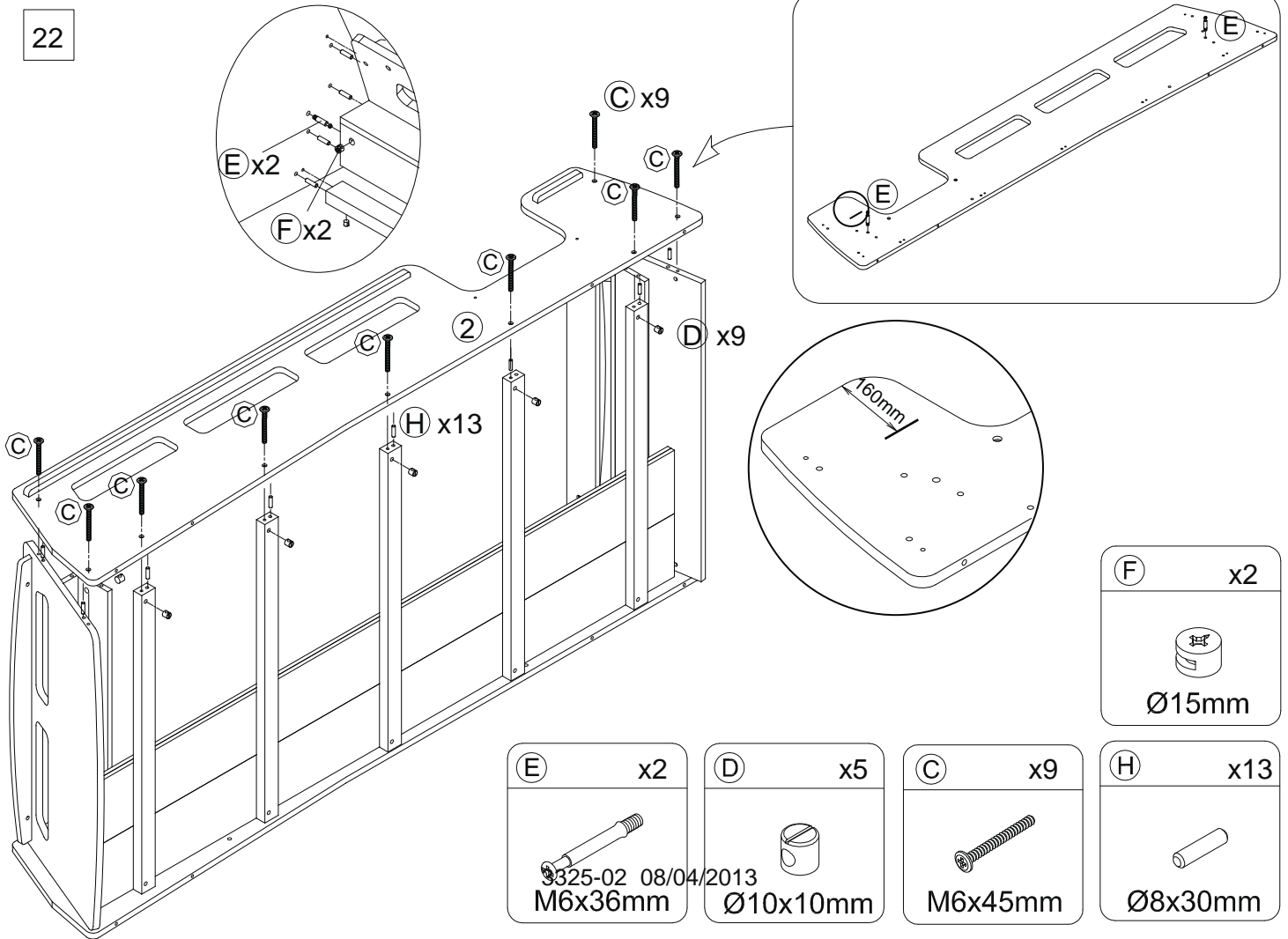

23

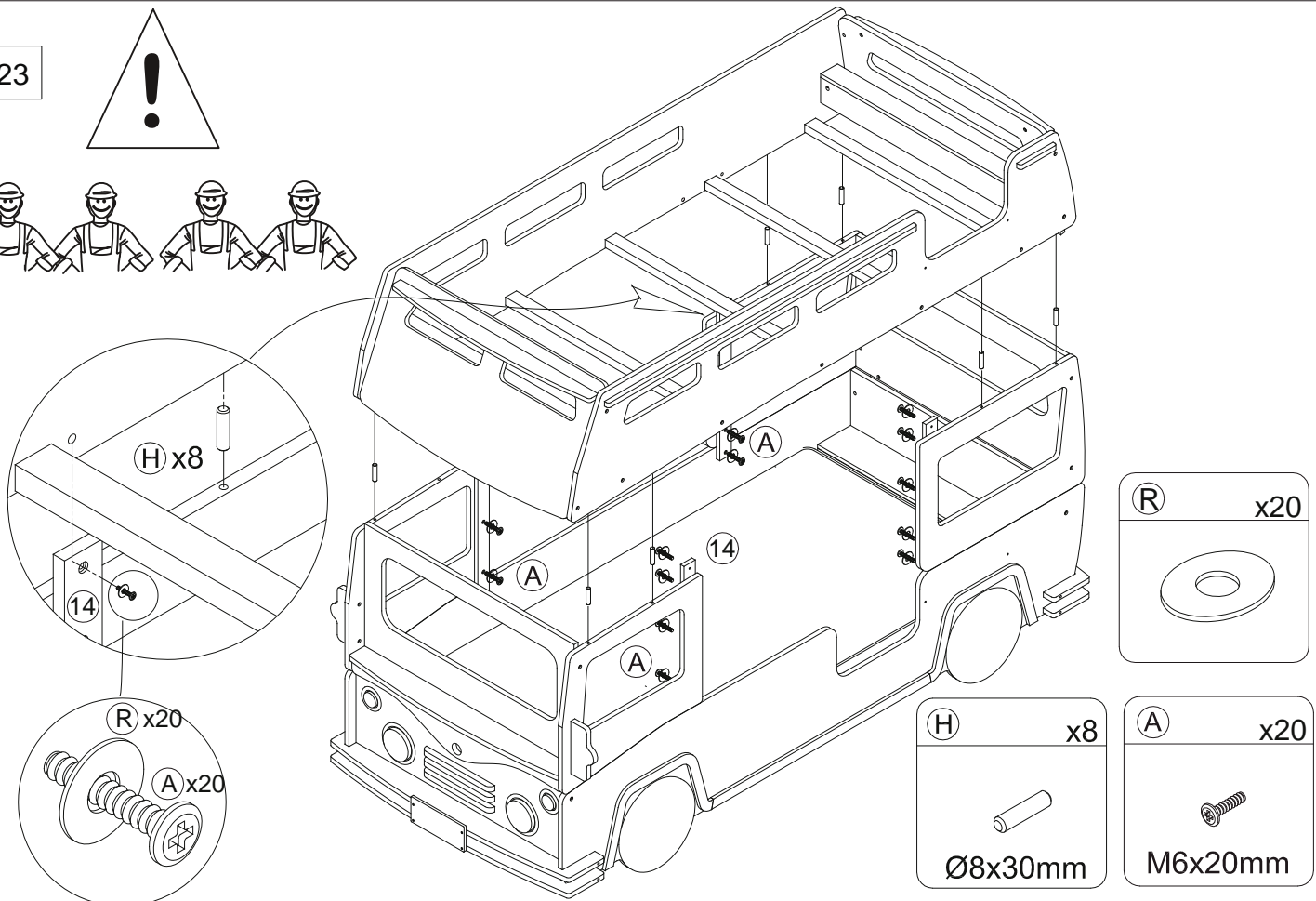

24

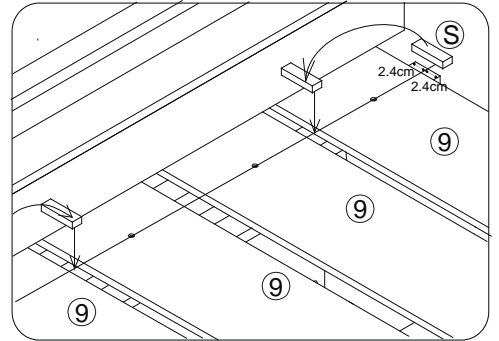
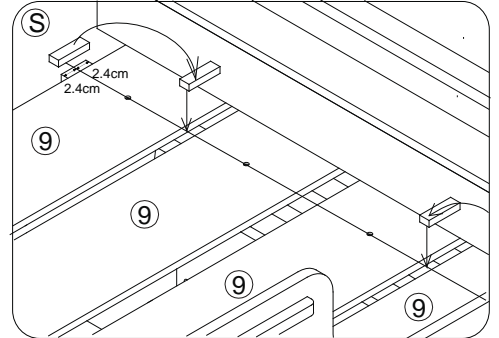
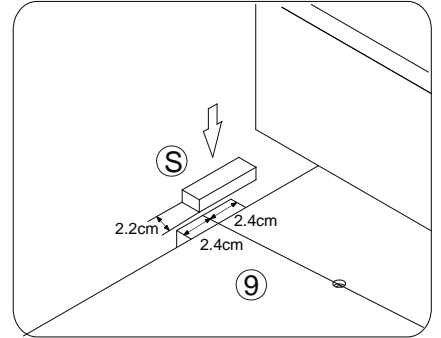
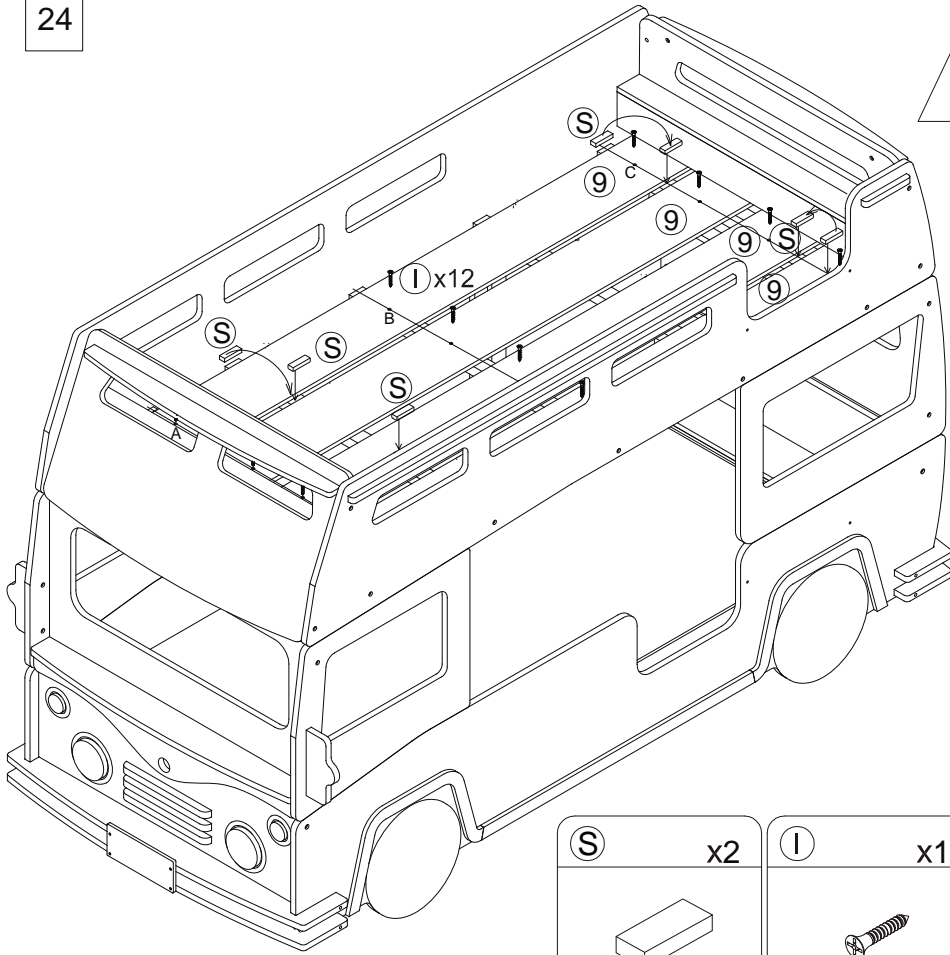

<b>S</b>	x2	<b>I</b>	x12
5Lx2.2Wx0.9T		M4x25mm	

25

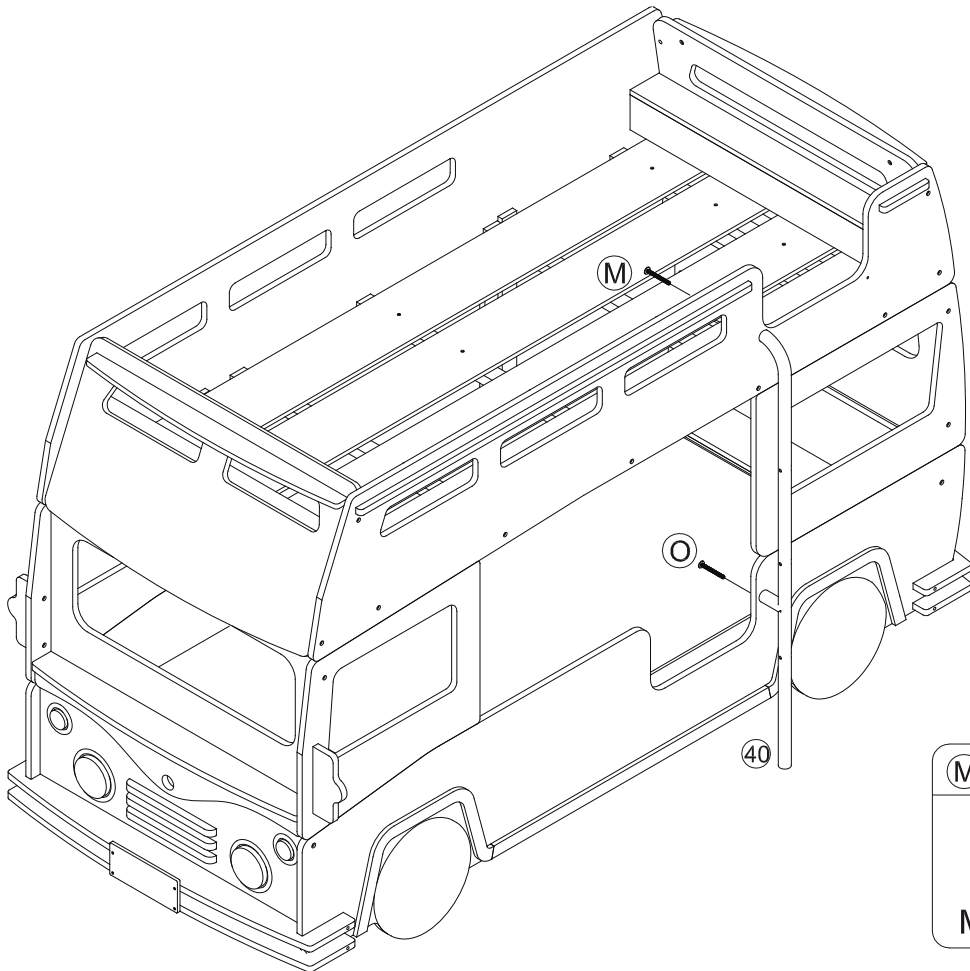

<b>M</b>	x1	<b>O</b>	x1
M8x35mm		M6x35mm	

26

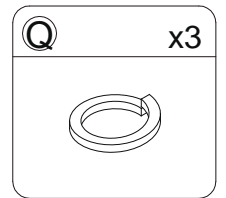
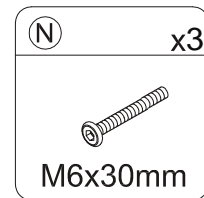
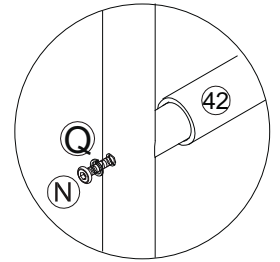
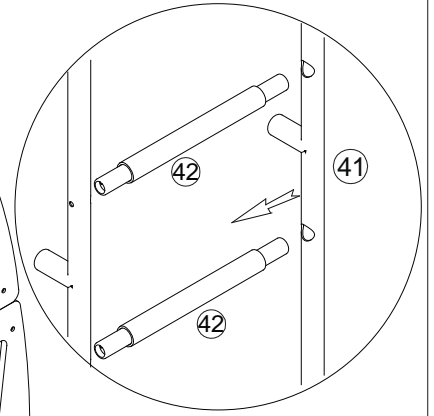
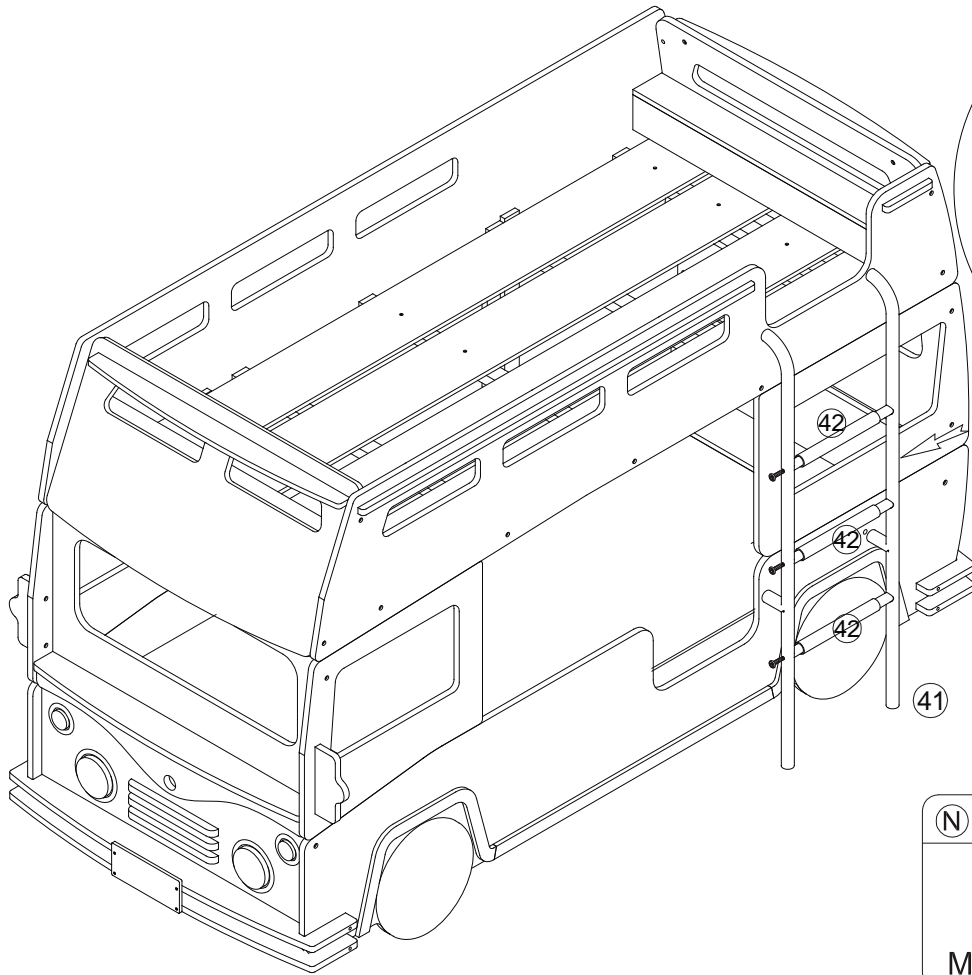

27

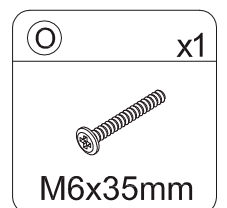
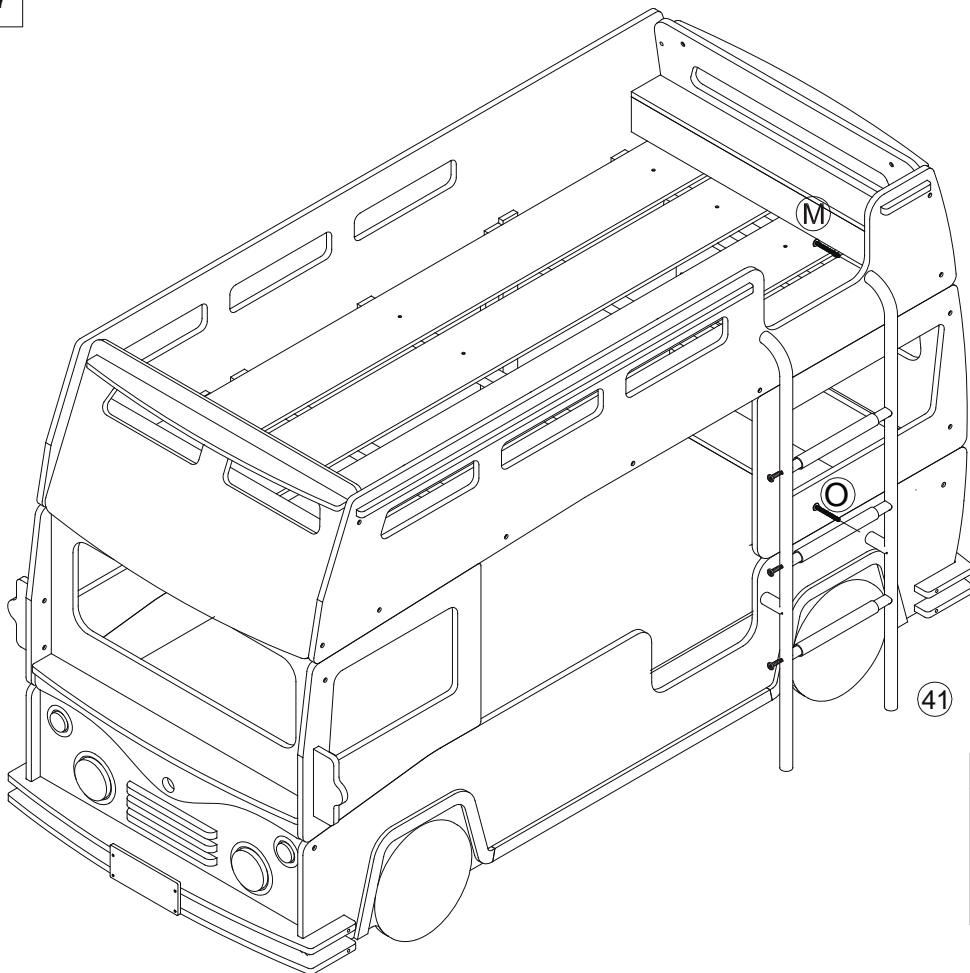

28

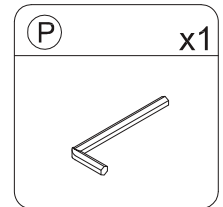
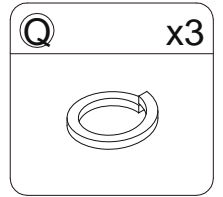
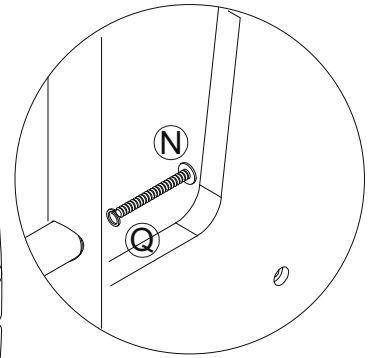
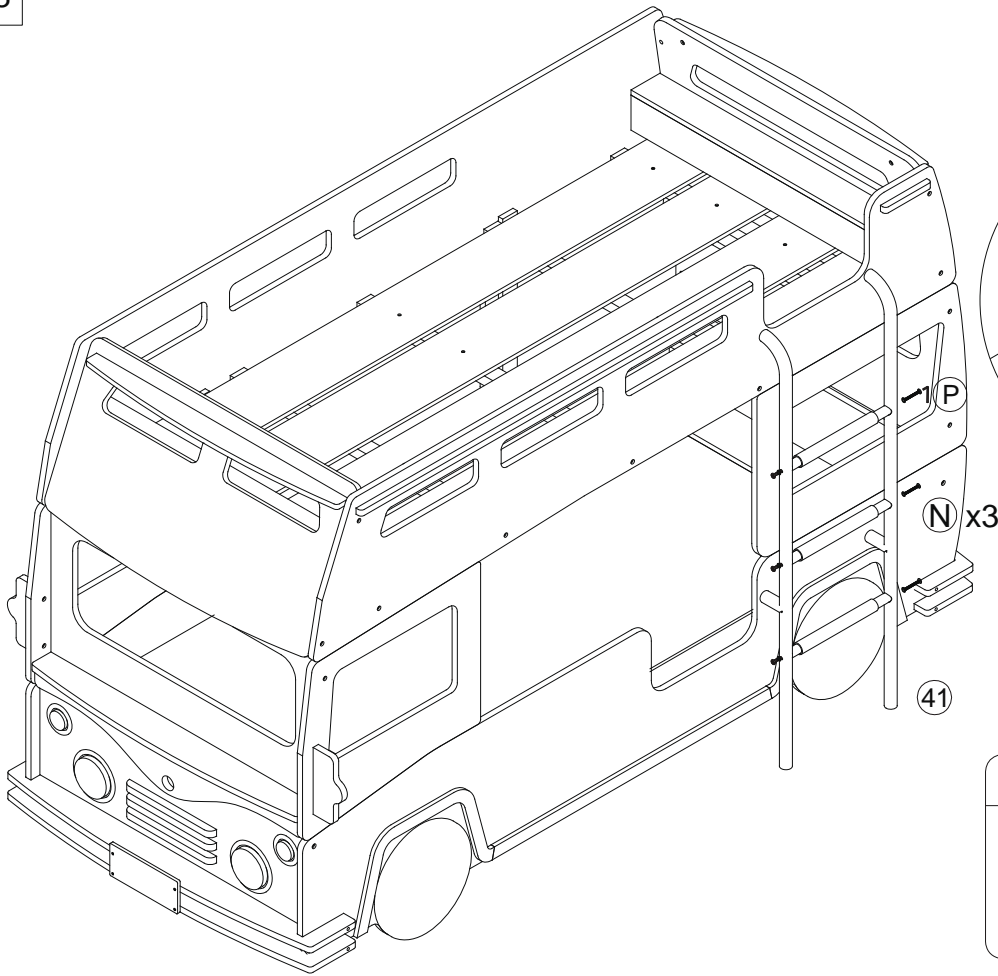

29

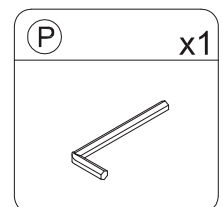
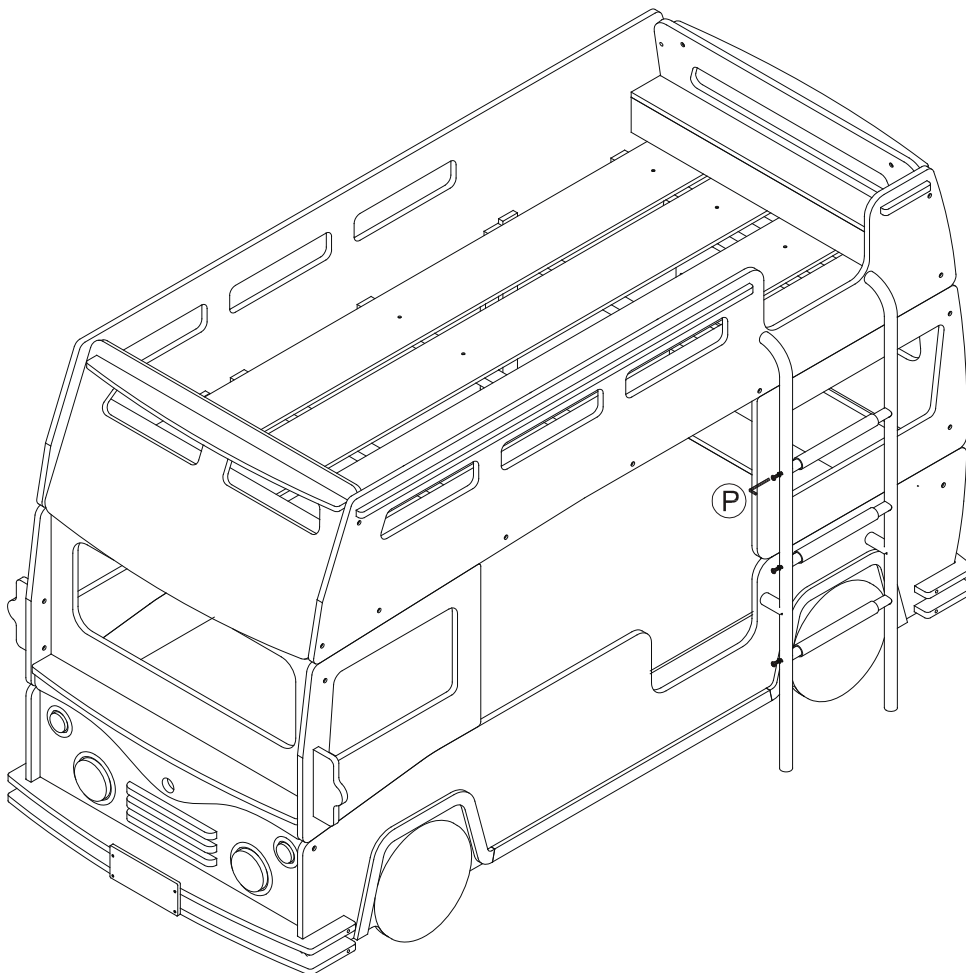

**END**

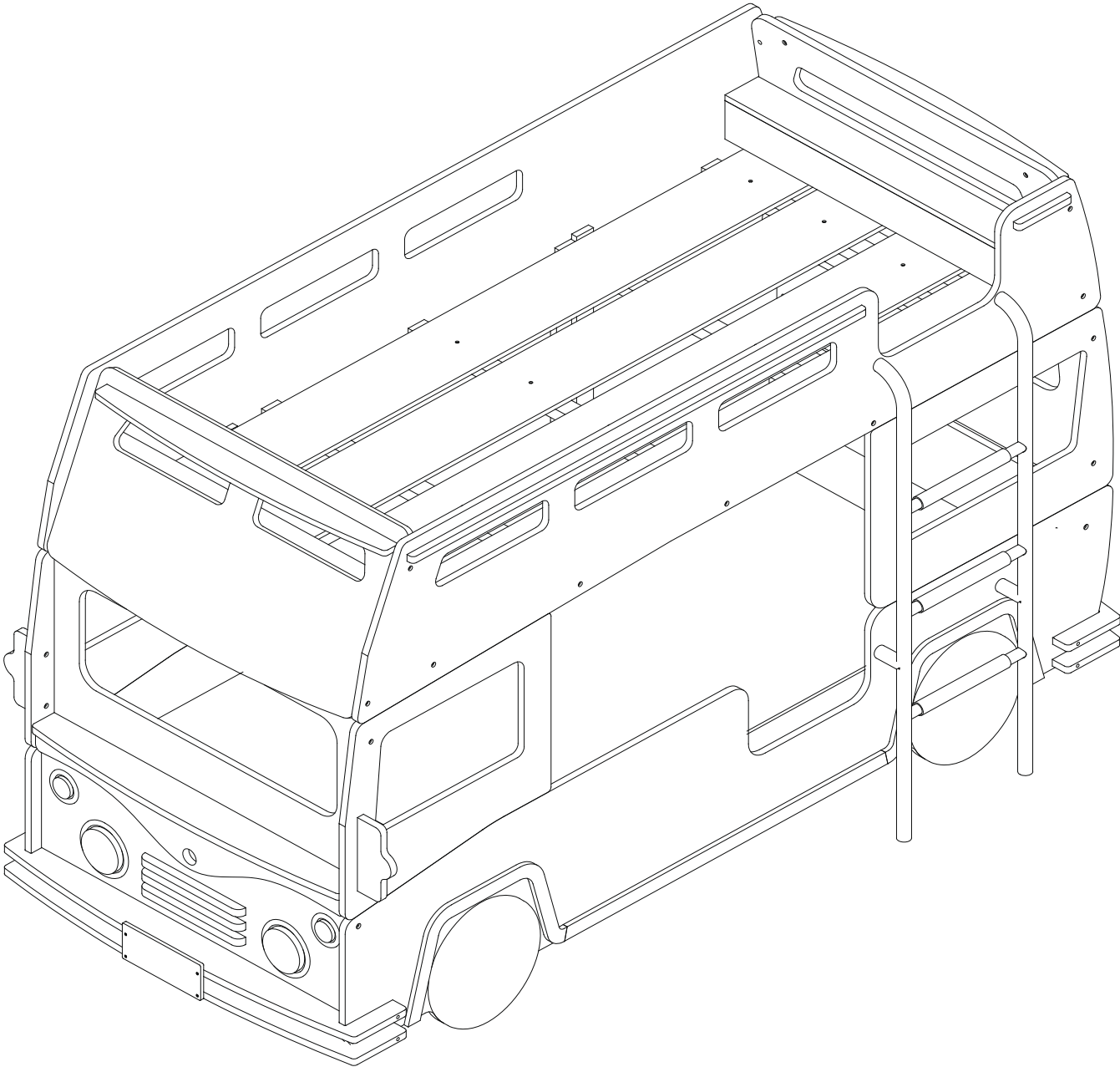



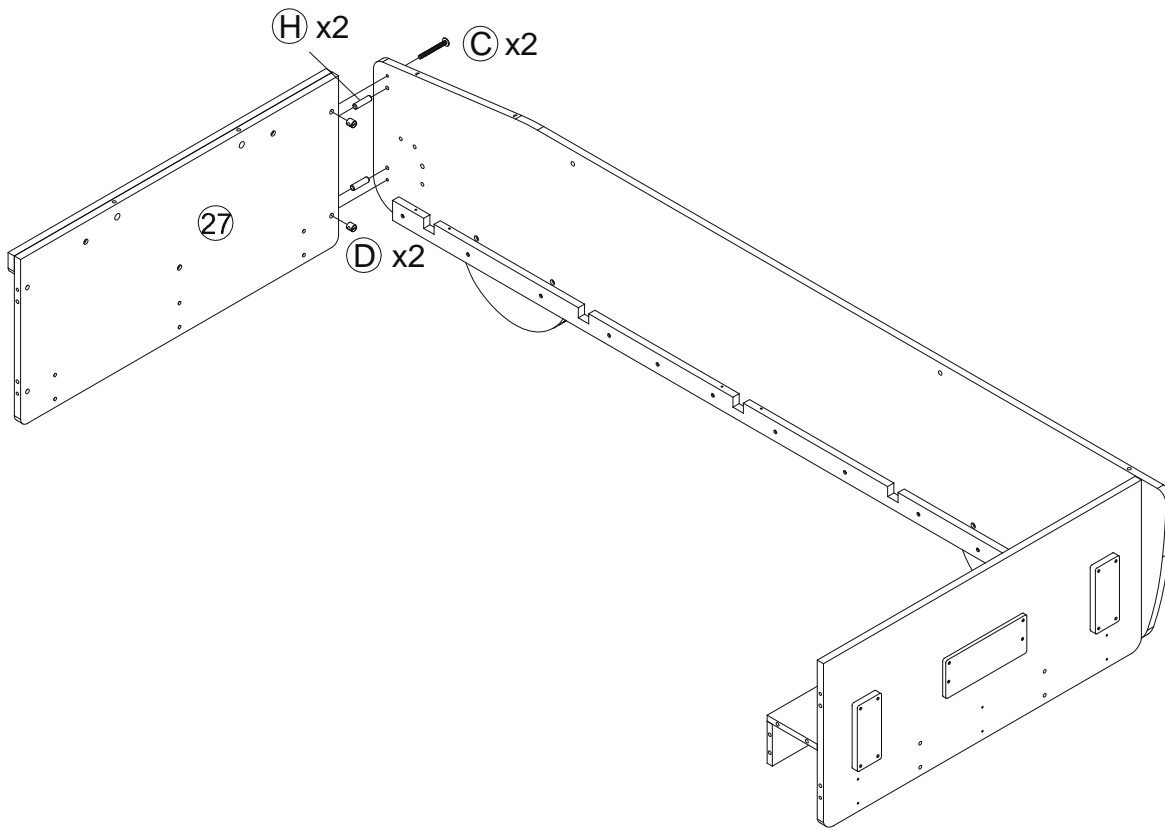

8



(C)	x2
	
M6x45mm	

(D)	x2
	
Ø10x10mm	

(H)	x2
	
Ø8x30mm	

9

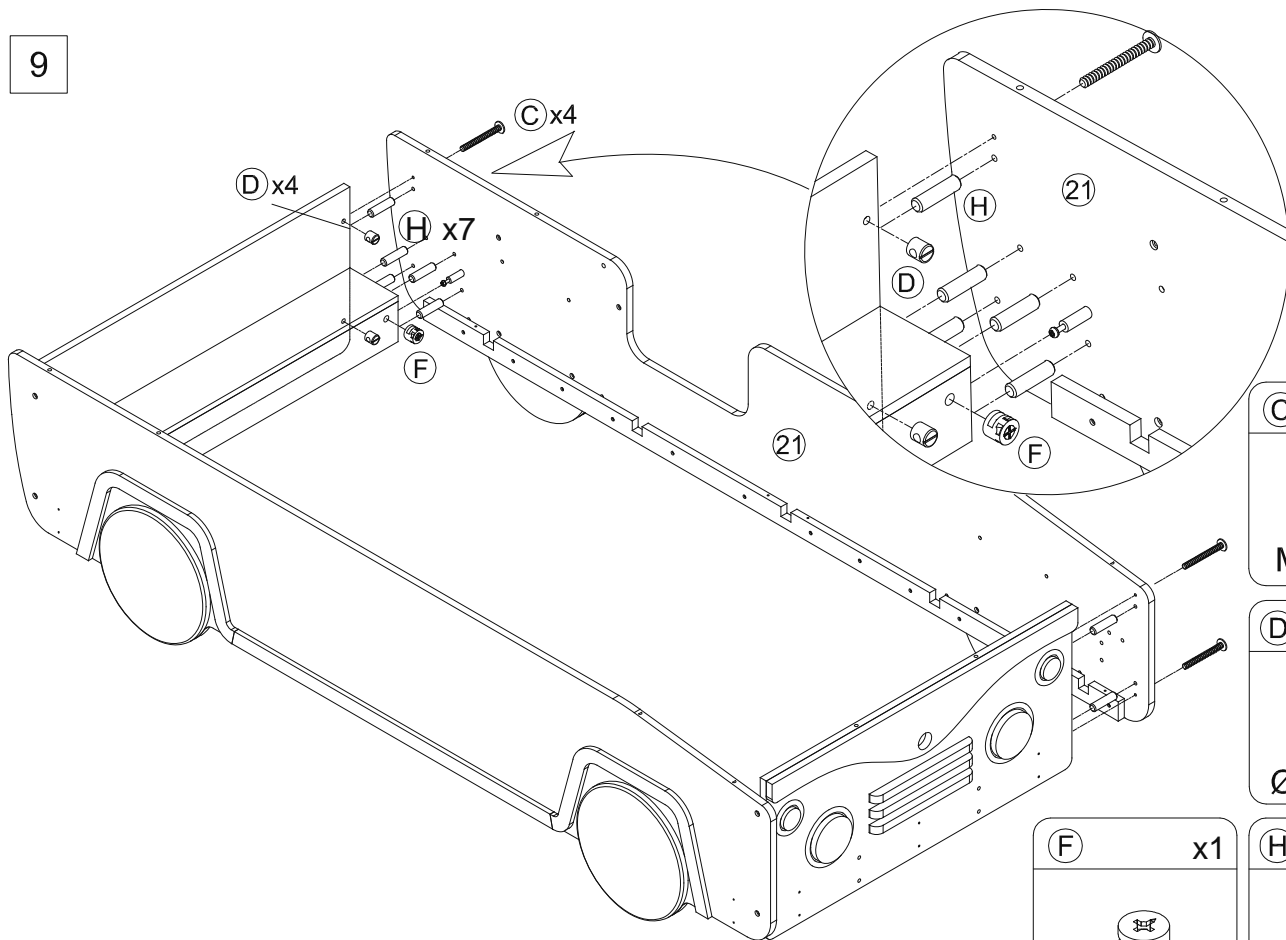

(C)	x4
	
M6x45mm	

(D)	x4
	
Ø10x10mm	

(F)	x1
	
Ø15mm	

(H)	x7
	
Ø8x30mm	

10

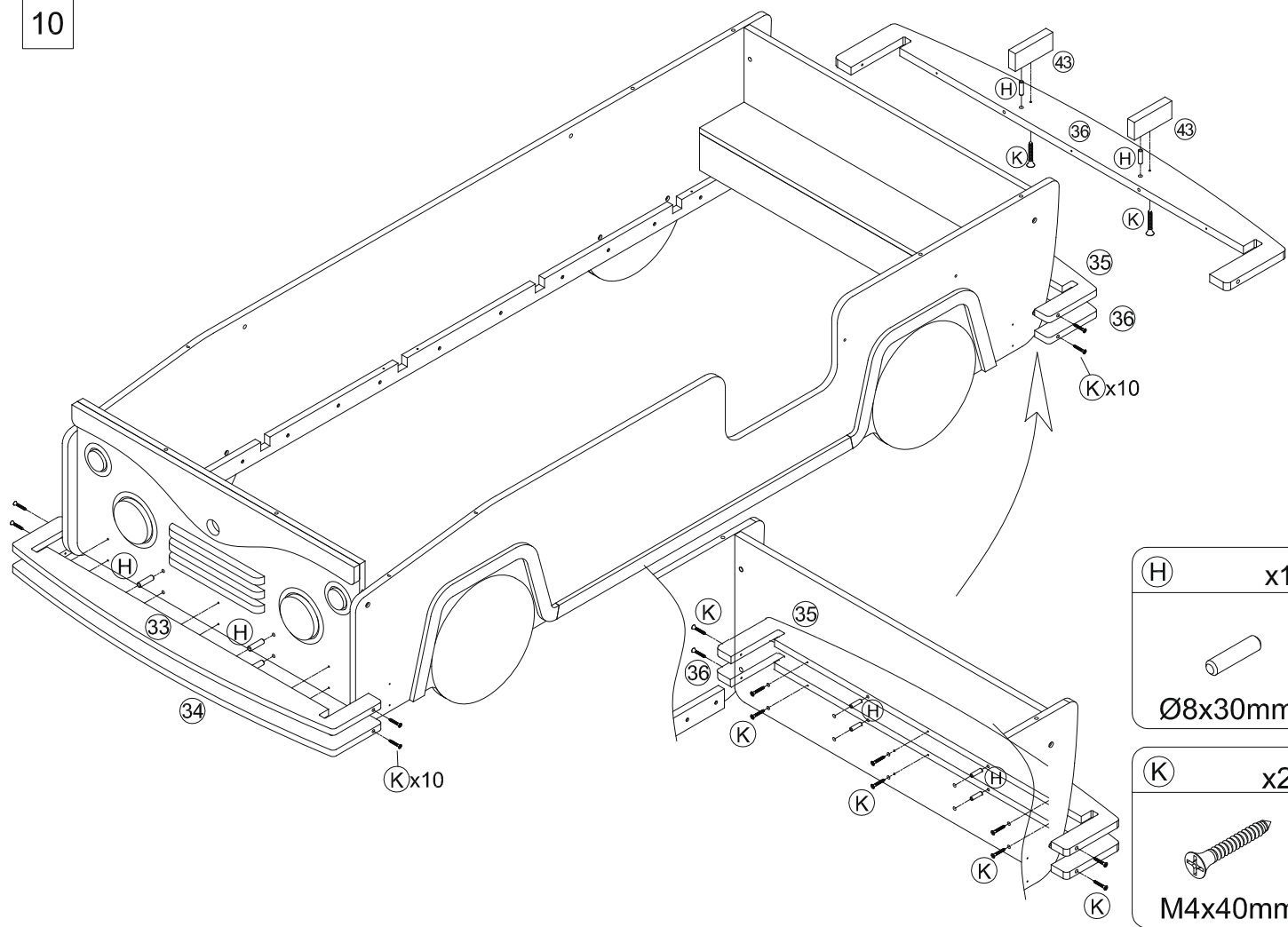

- (H) x10  
Ø8x30mm
- (K) x22  
M4x40mm

11

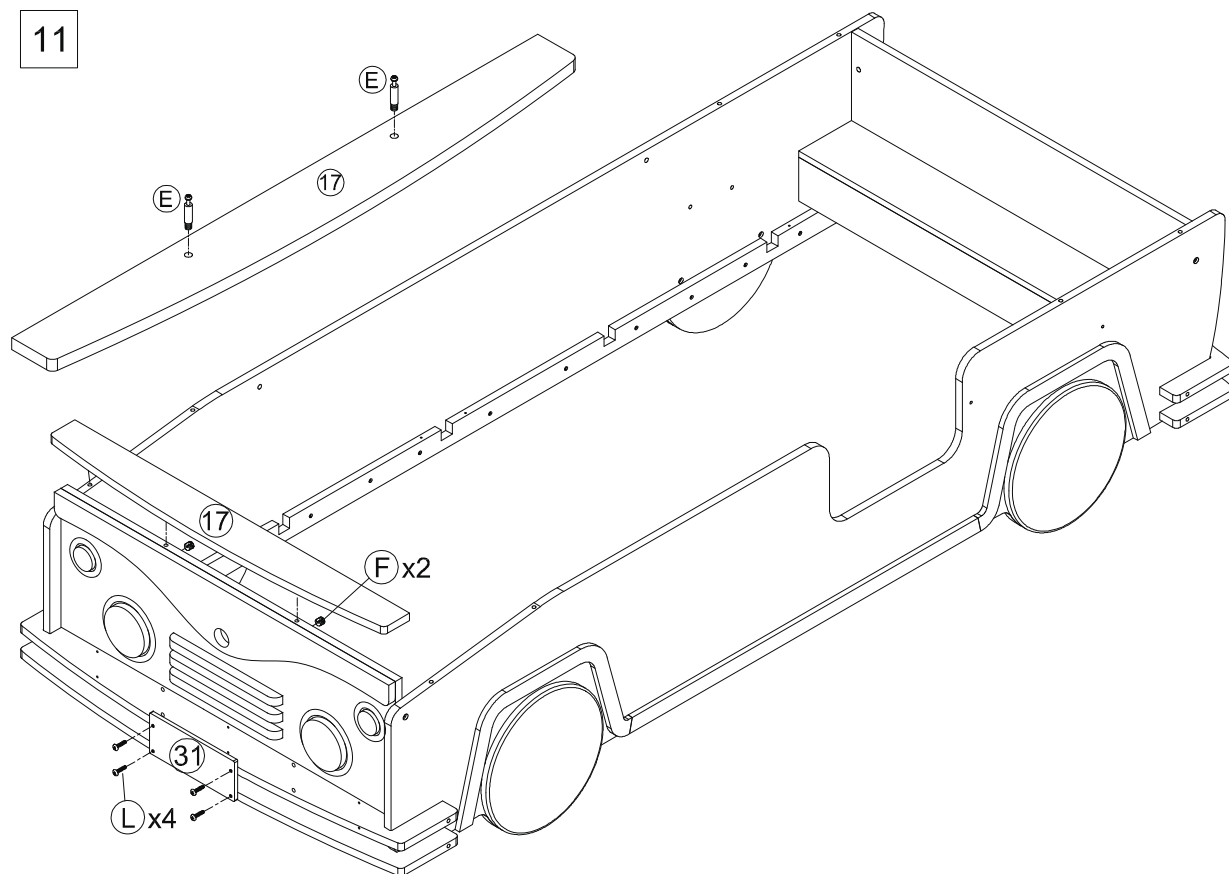

- (E) x2  
M6x36mm
- (F) x2  
Ø15mm
- (L) x4  
M3x20mm

12

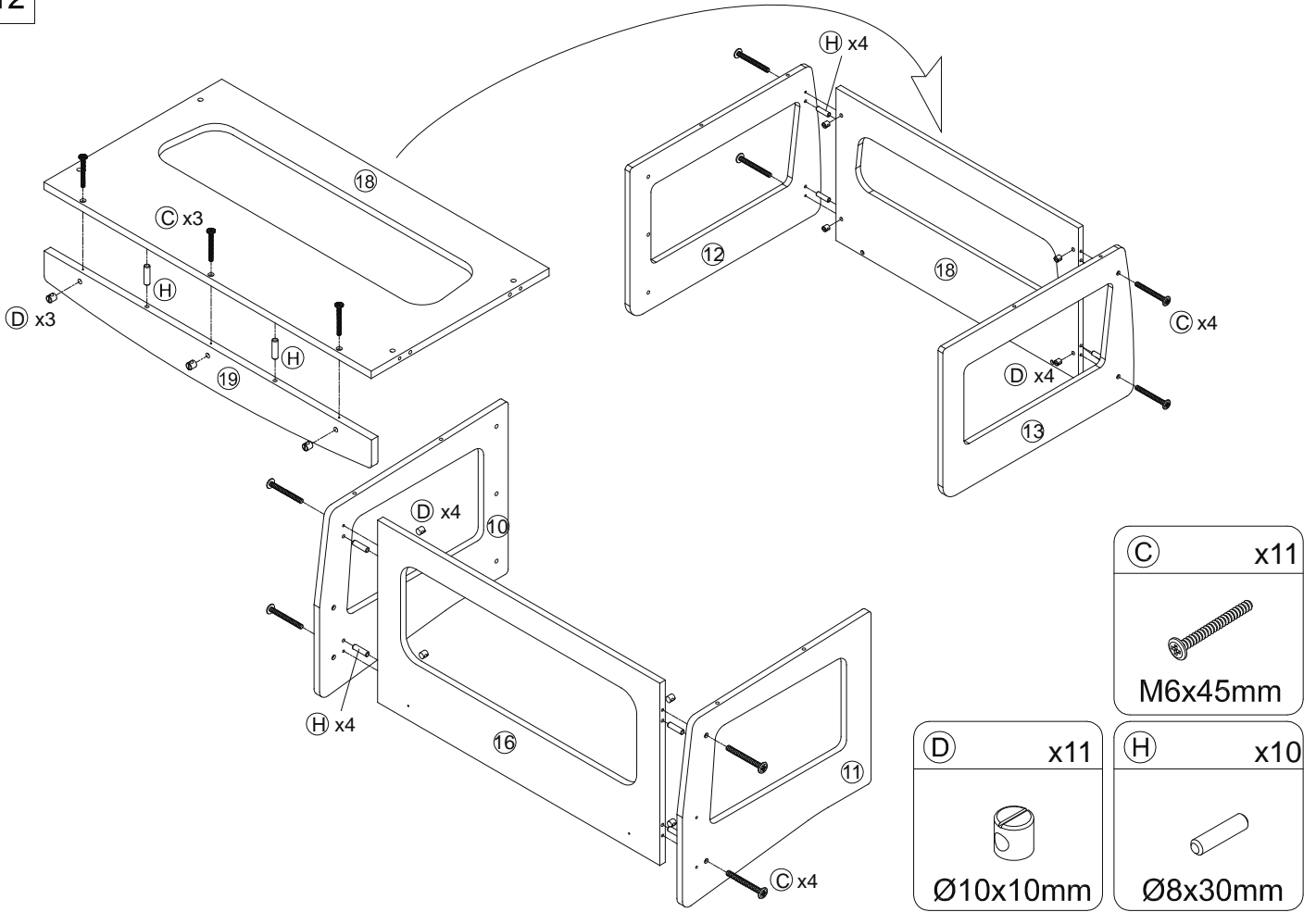

13

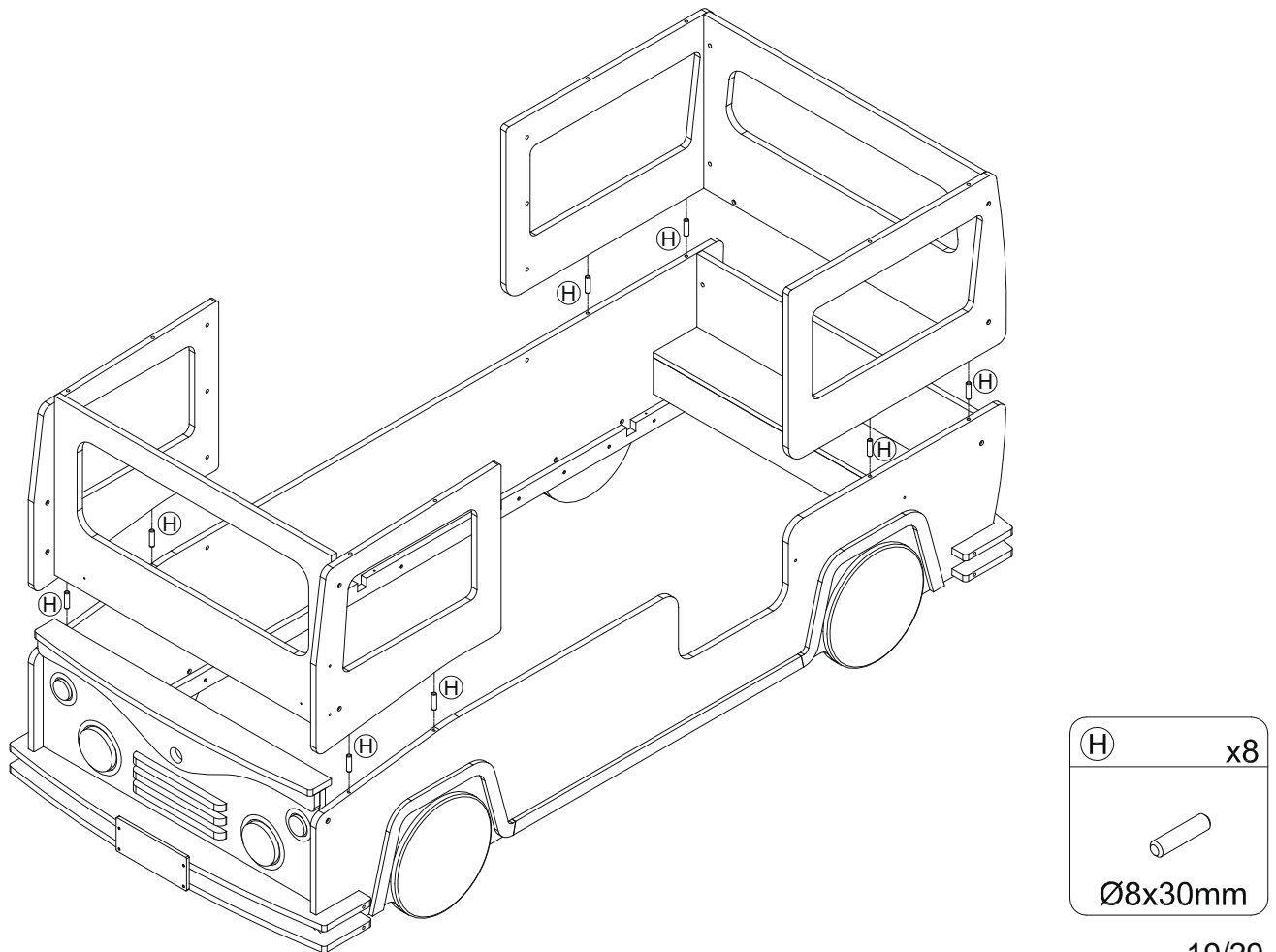

14

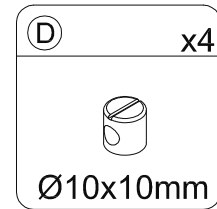
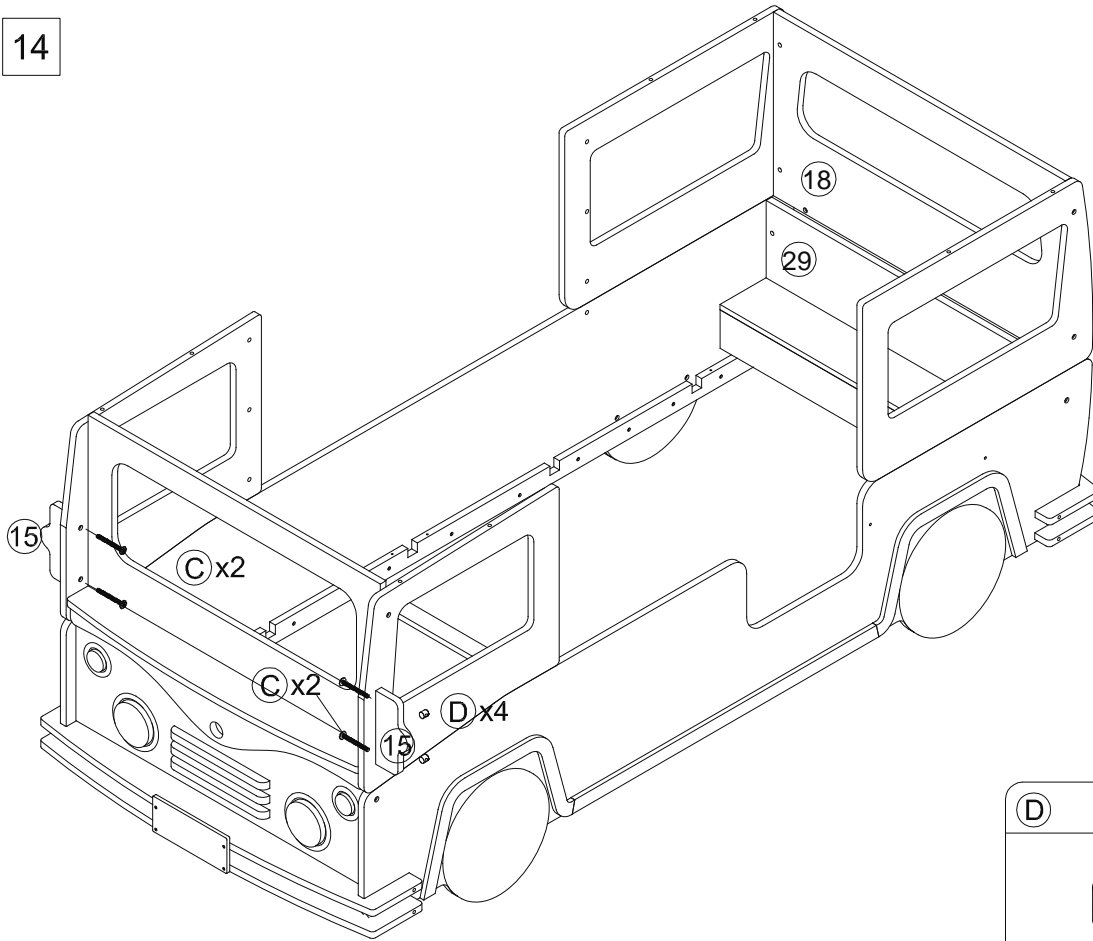

15

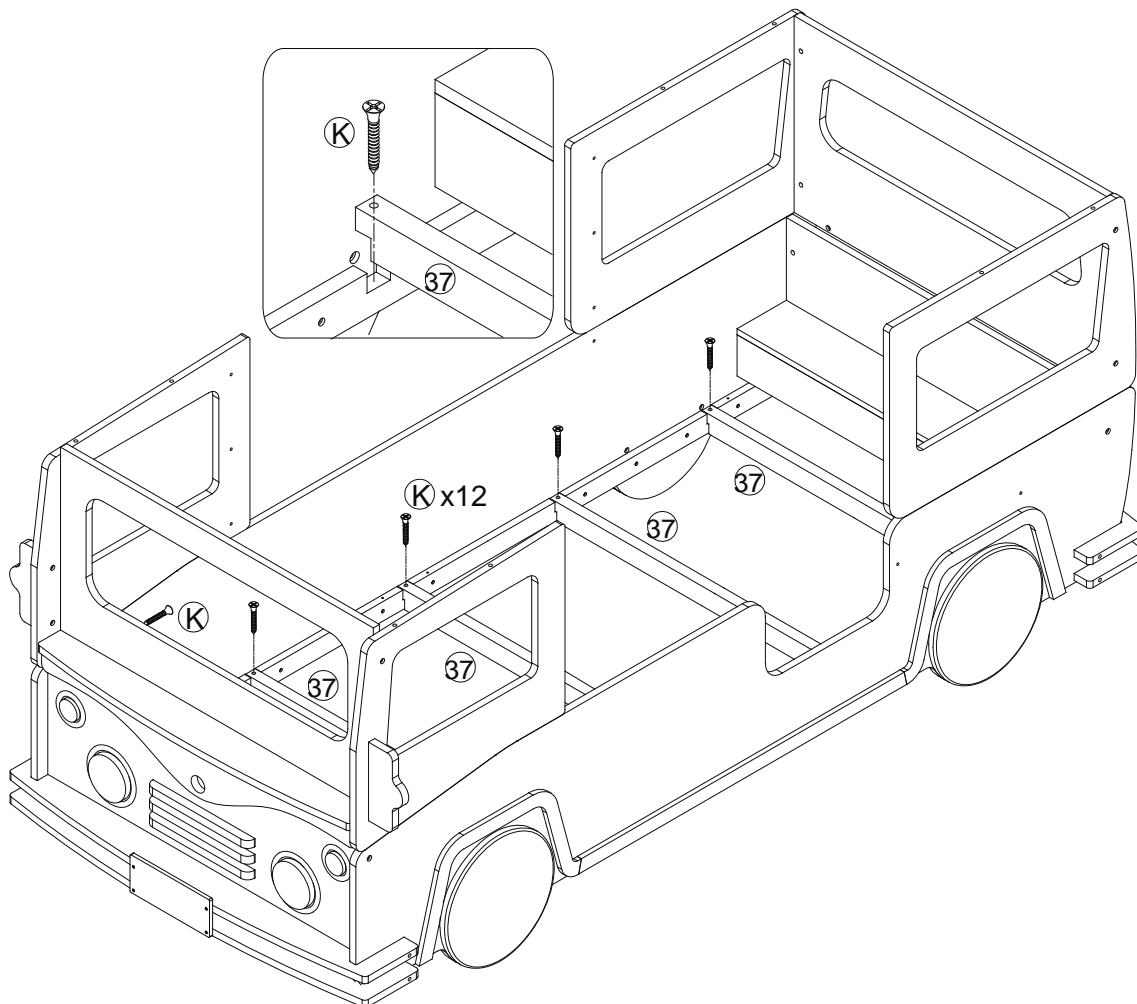

16

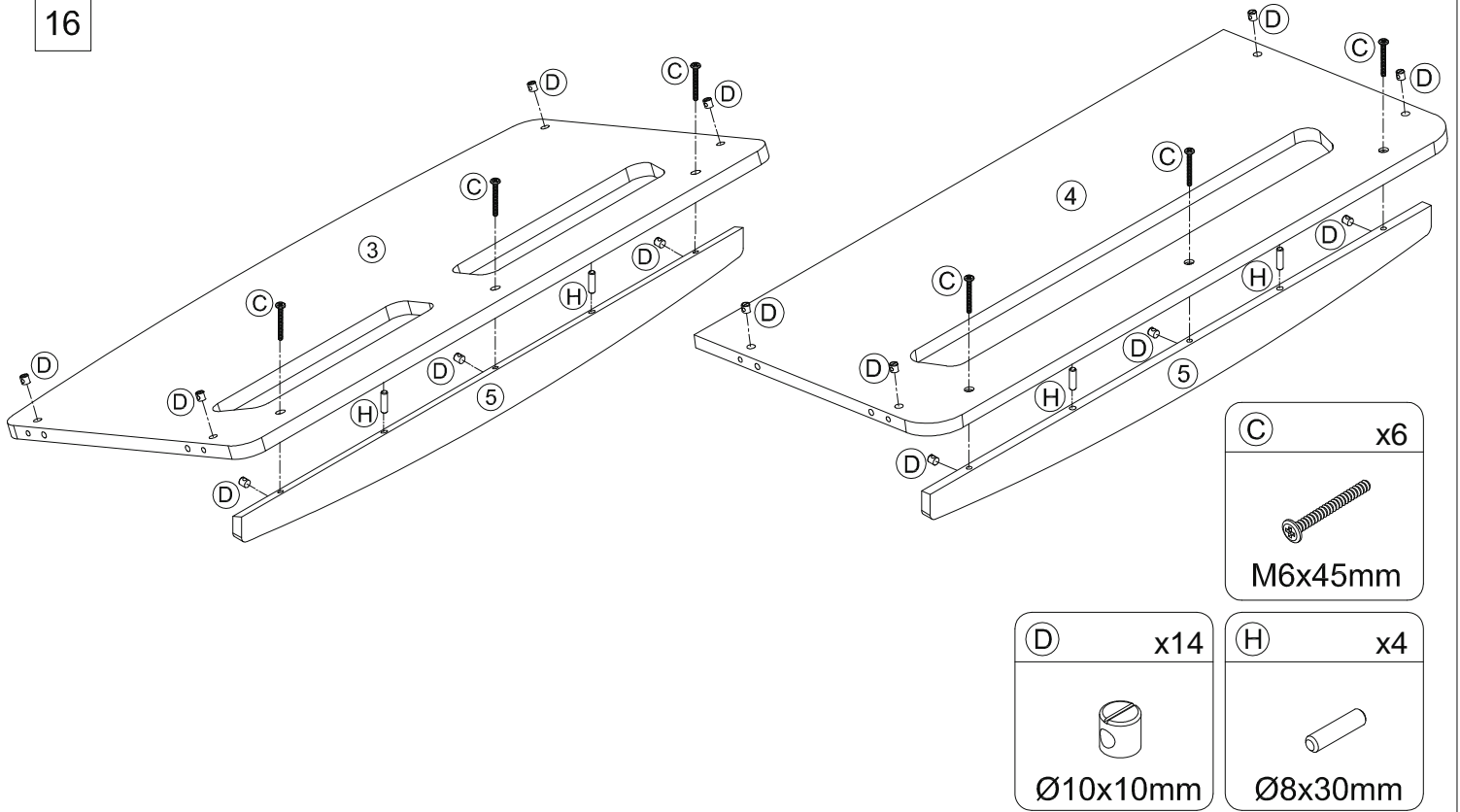

17

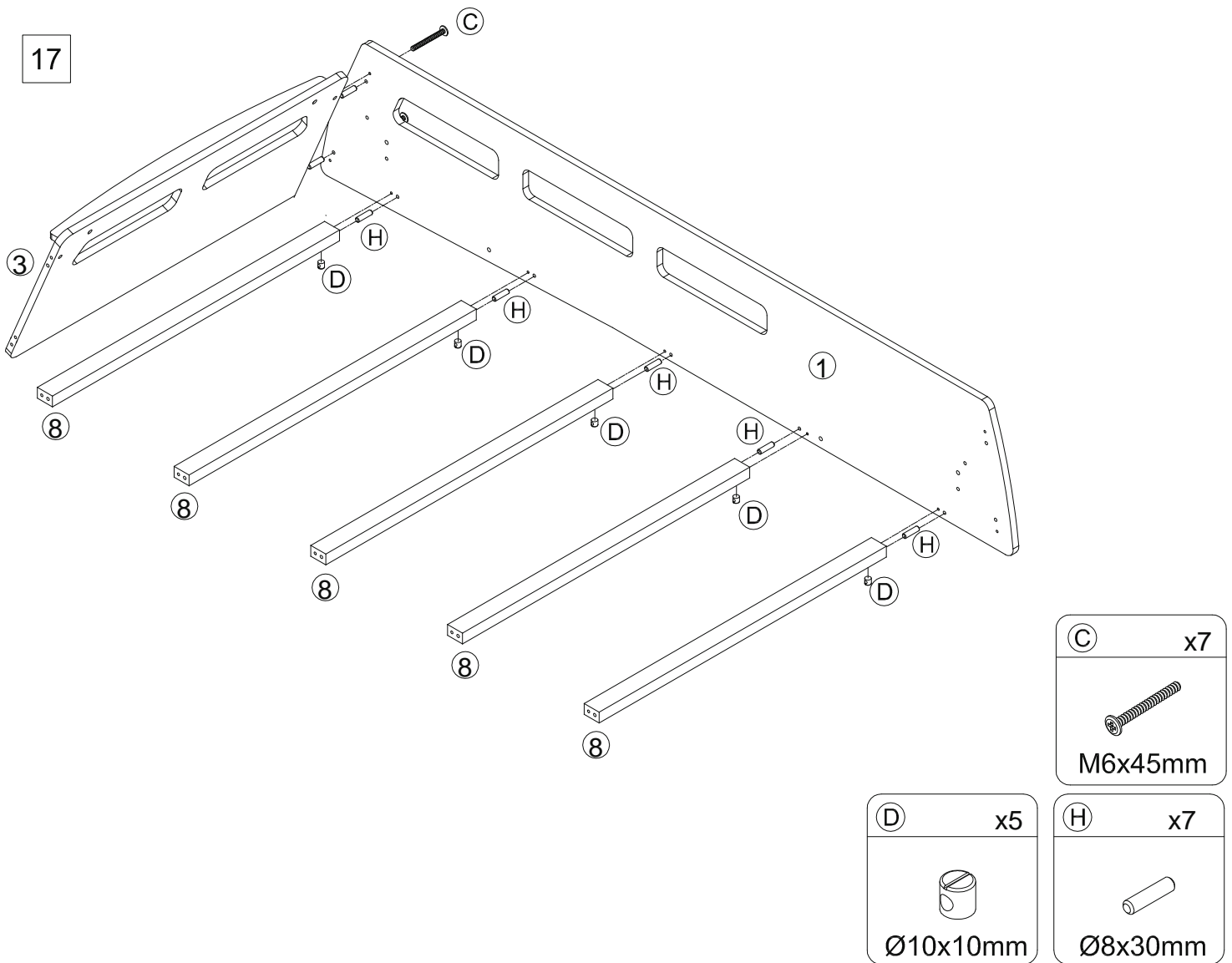

18

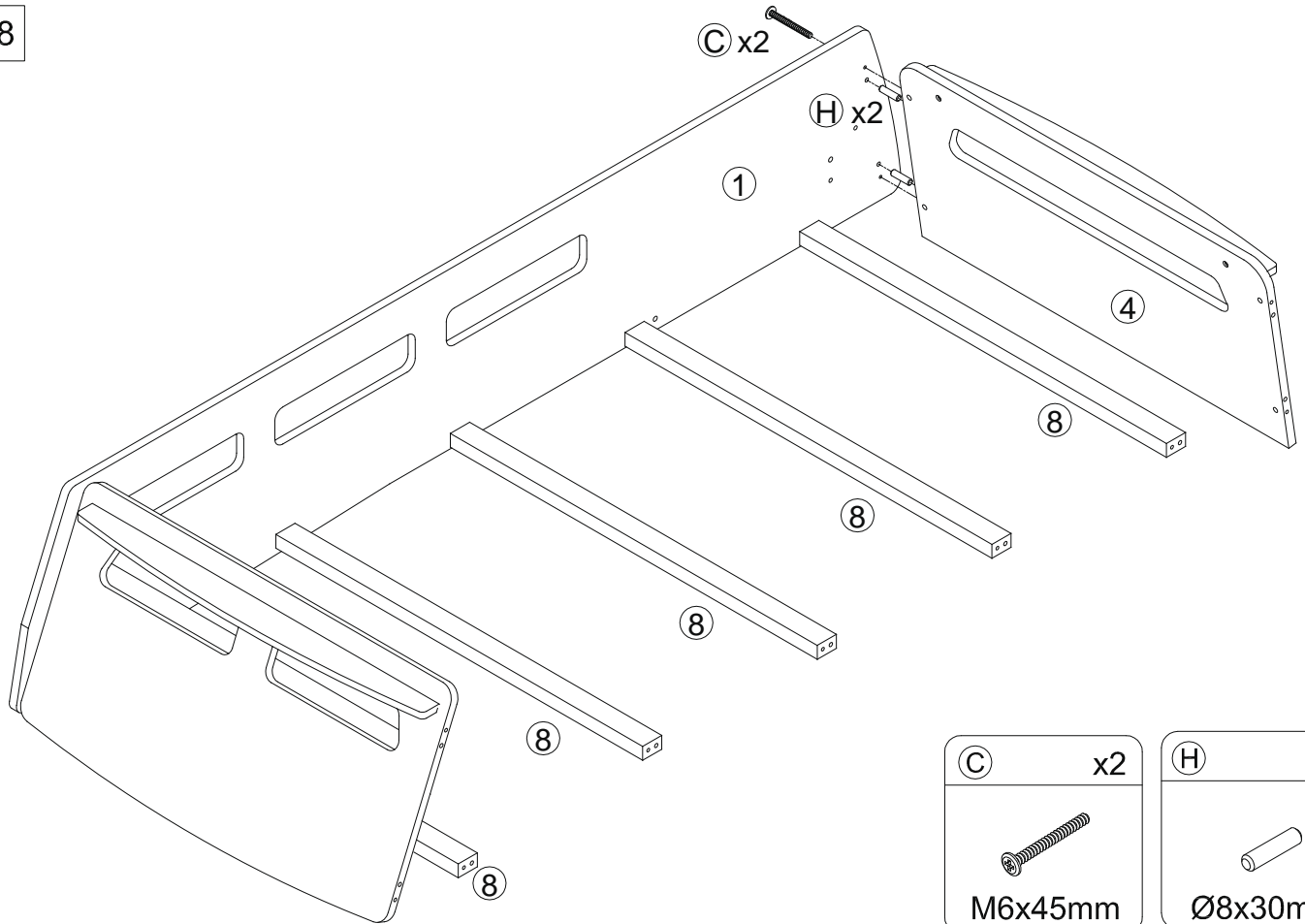

19

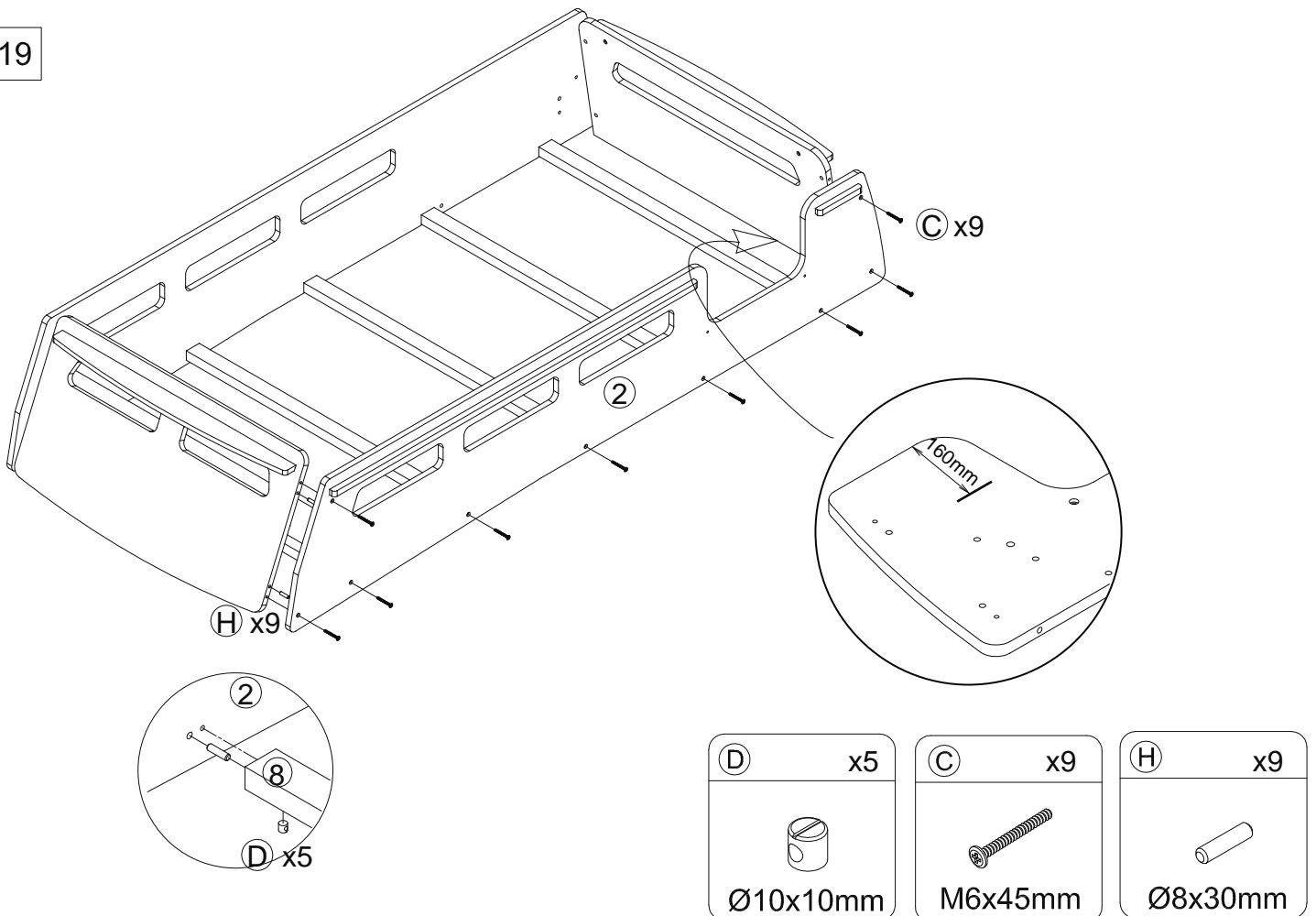

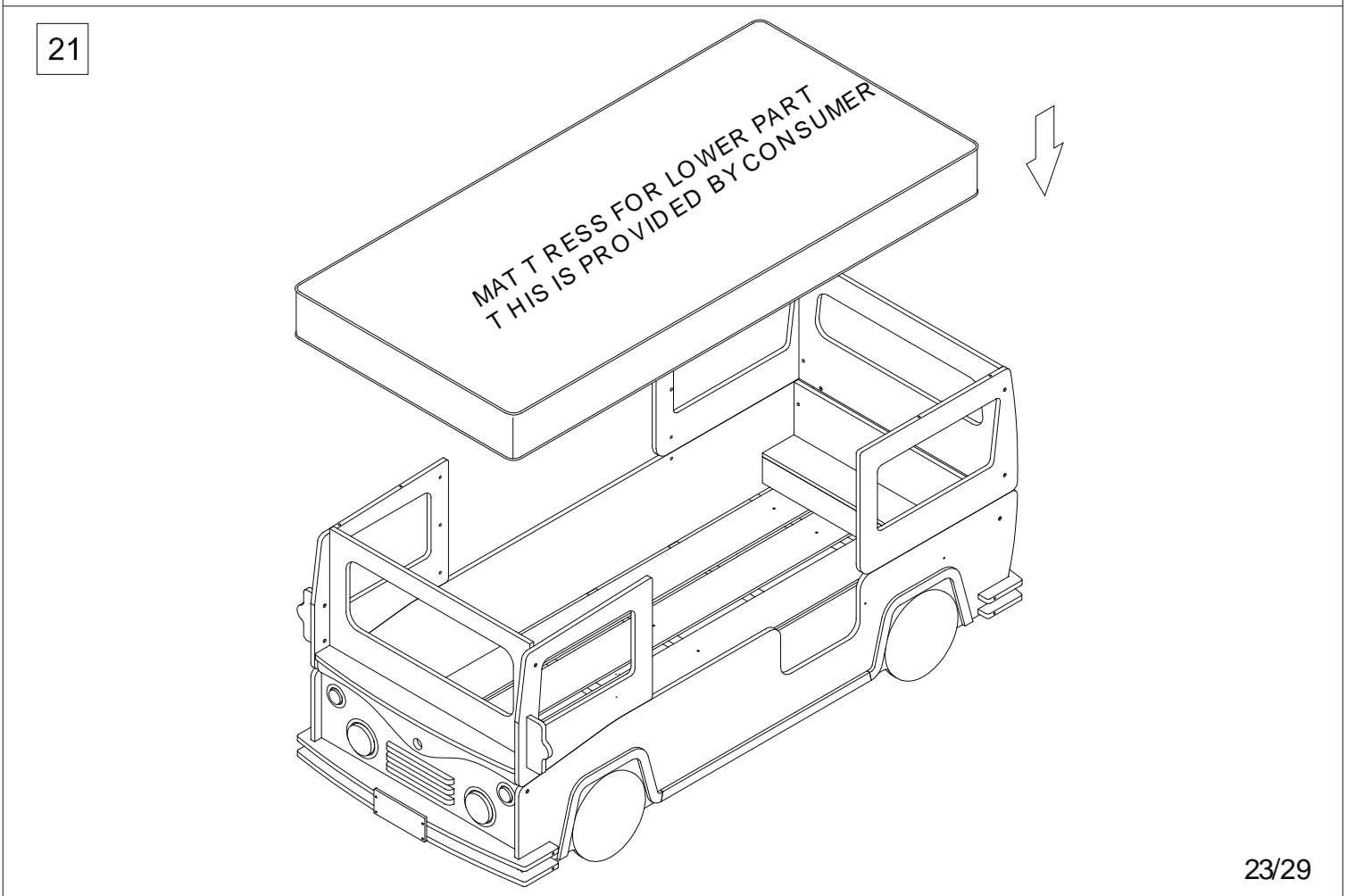
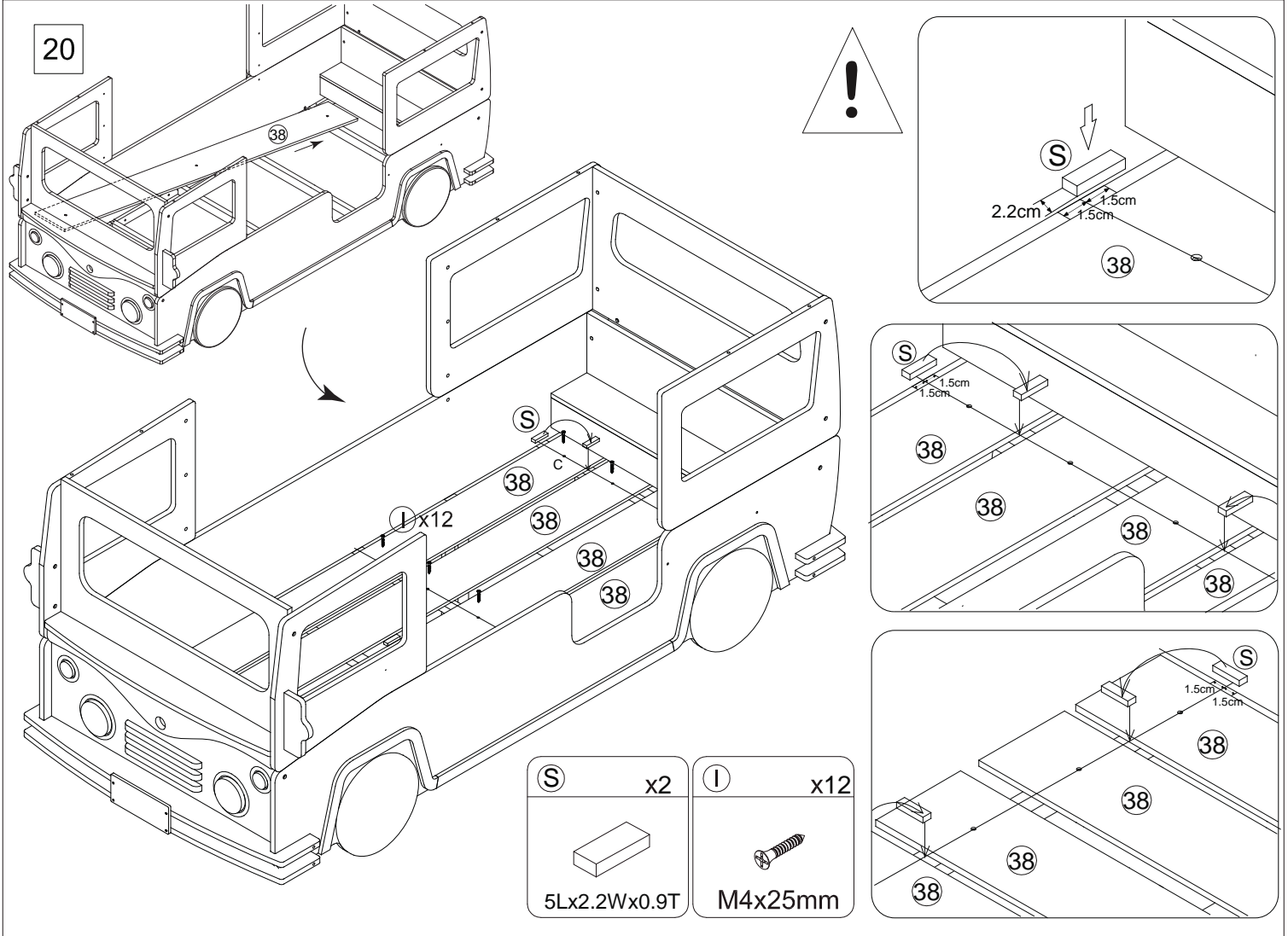

22

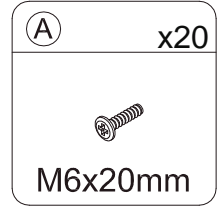
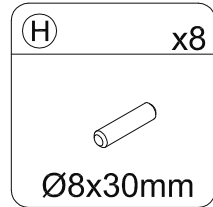
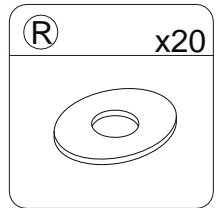
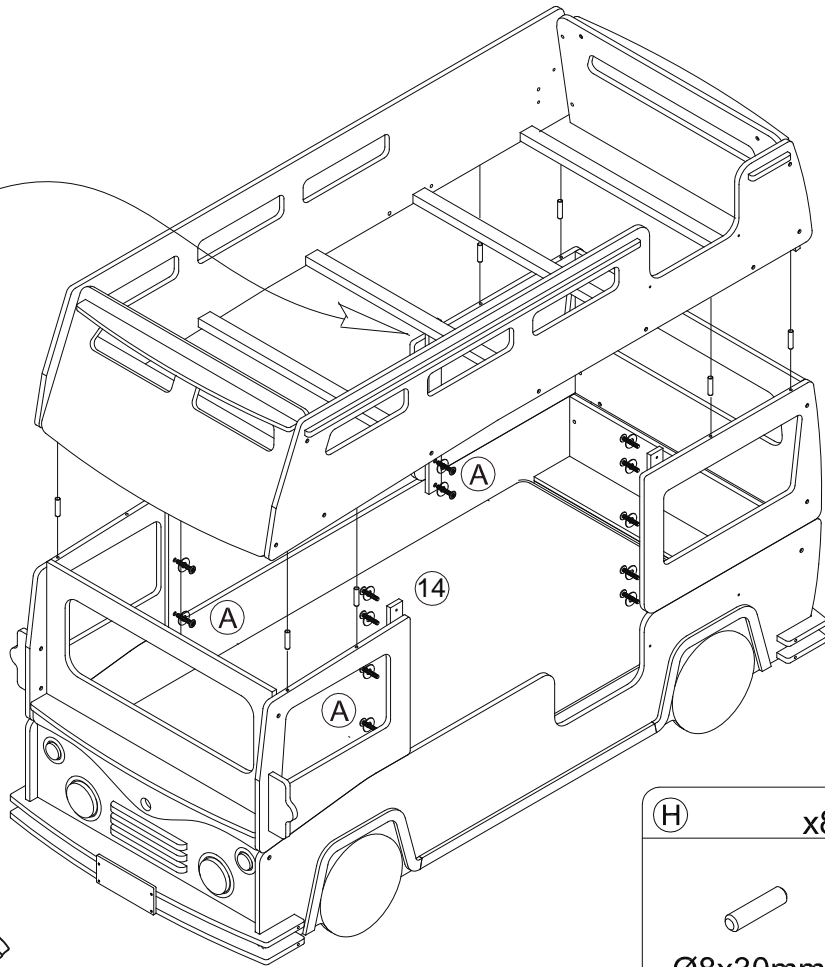
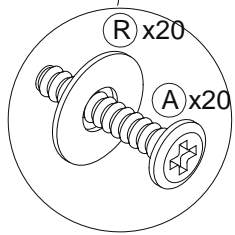
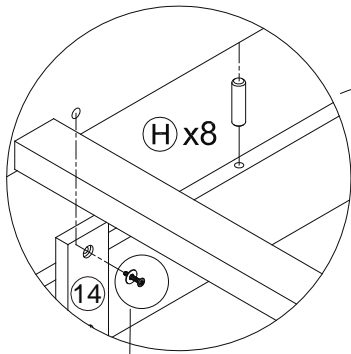

23

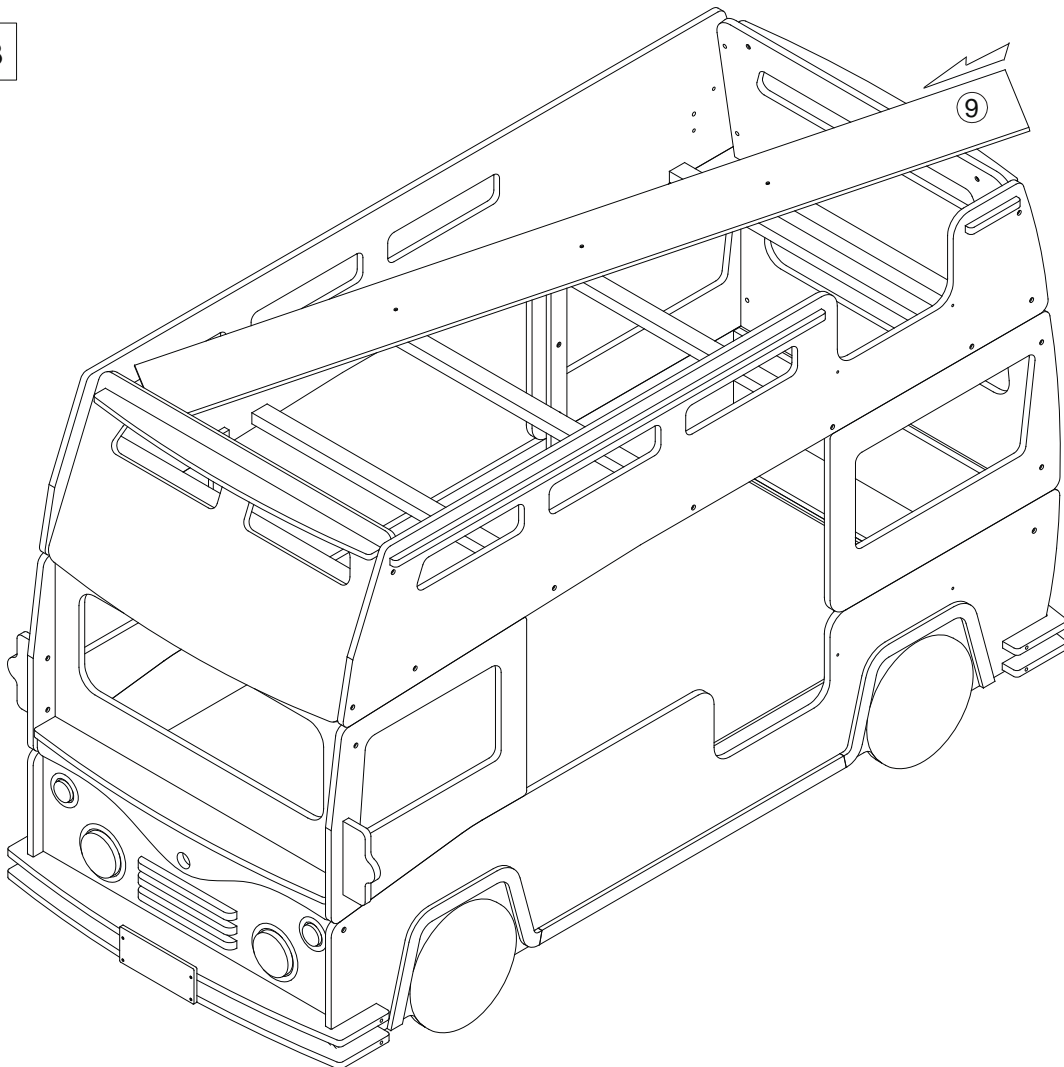



24

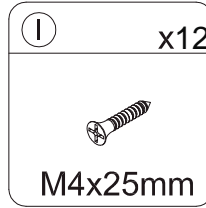
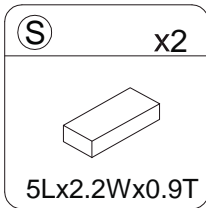
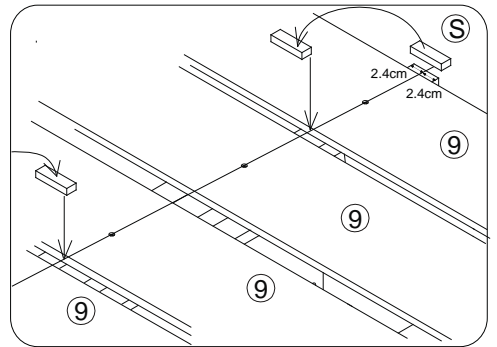
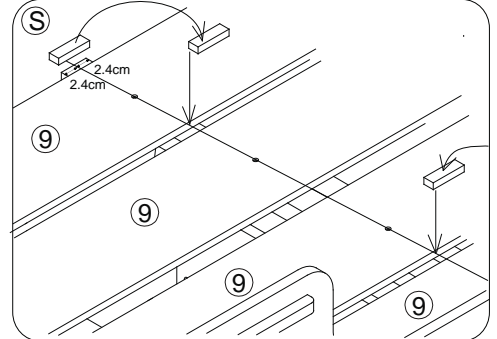
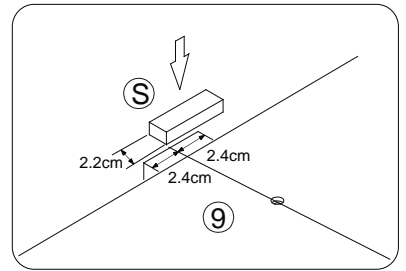
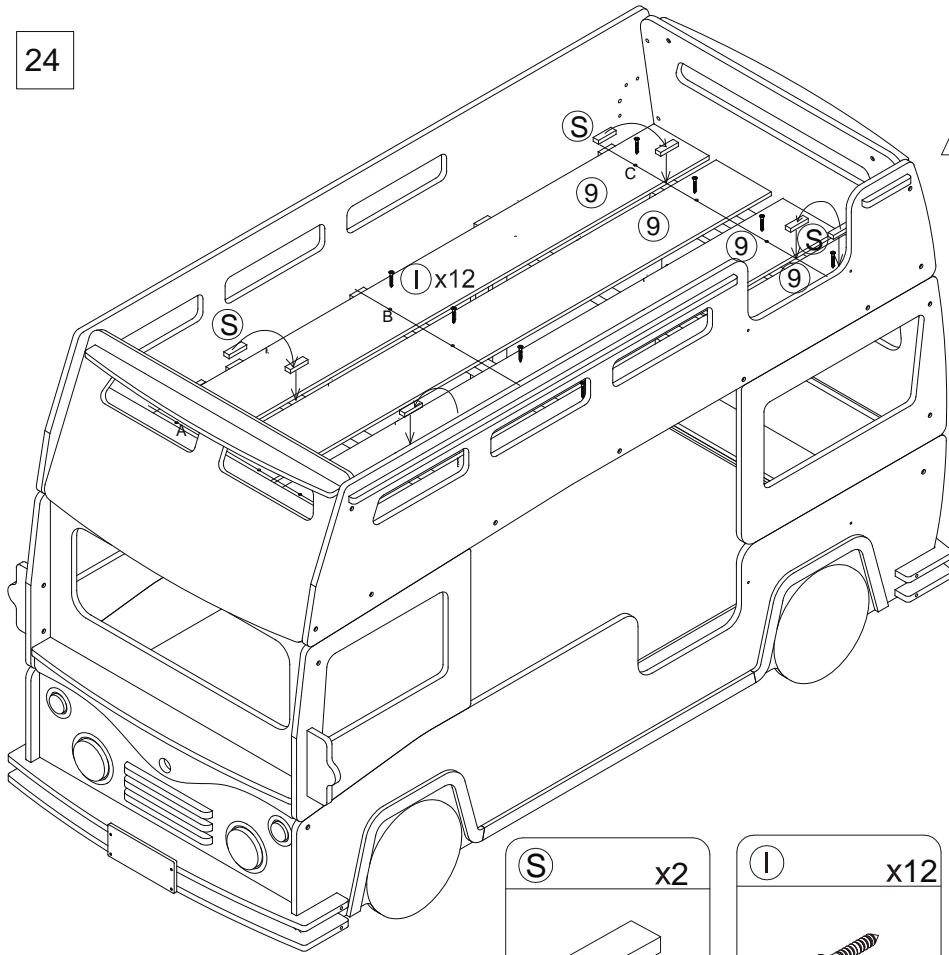

25

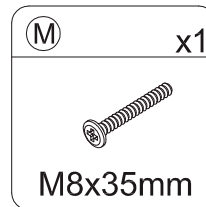
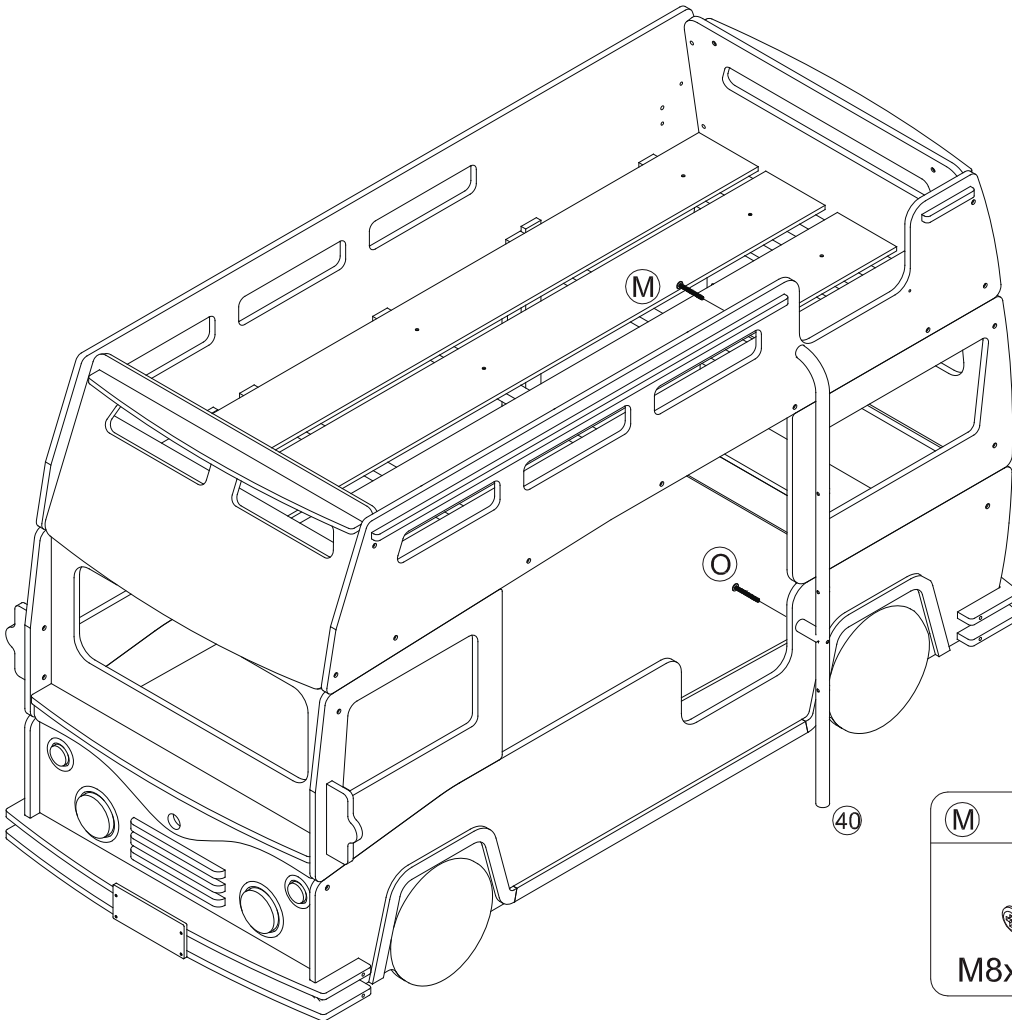

26

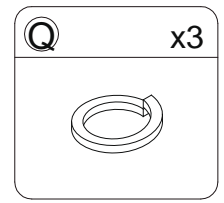
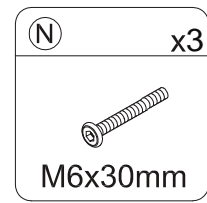
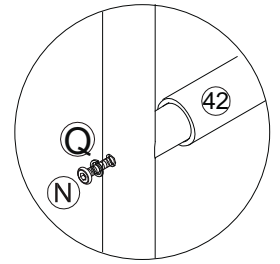
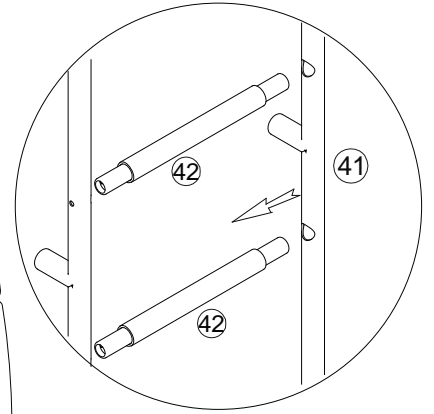
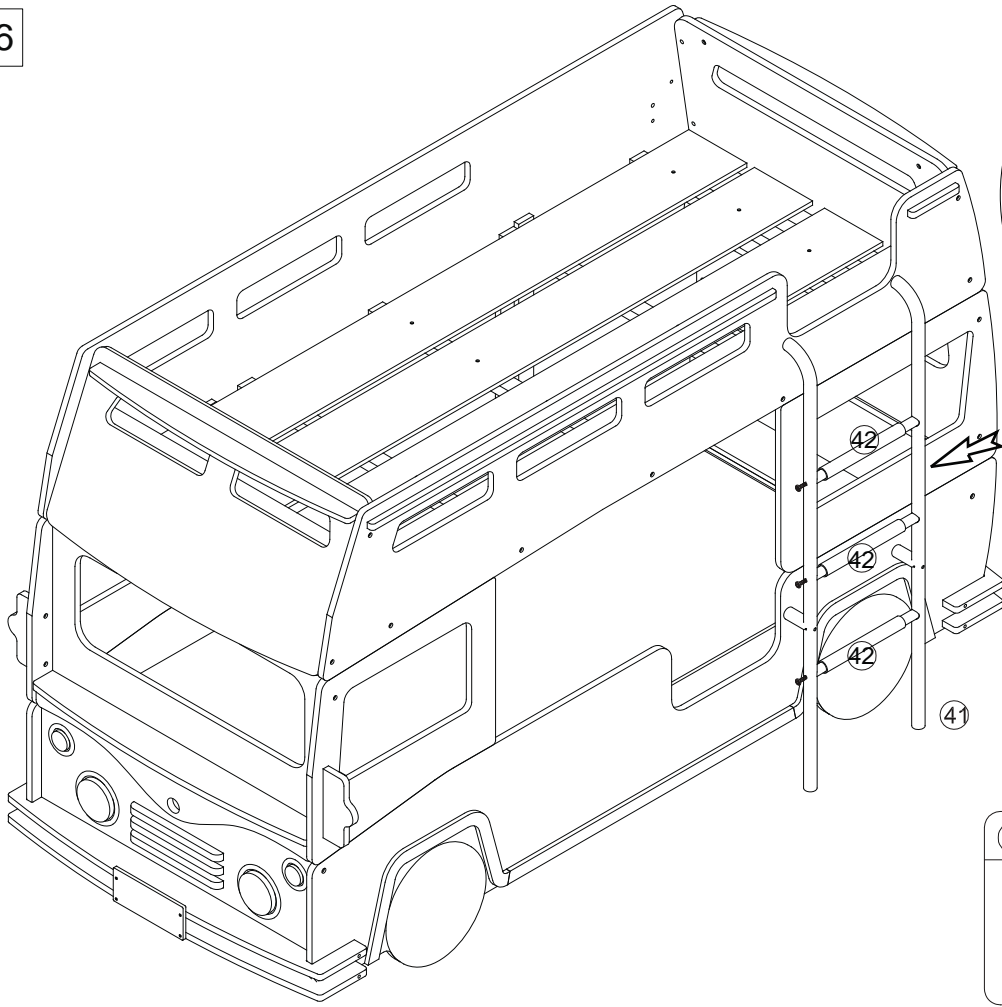

27

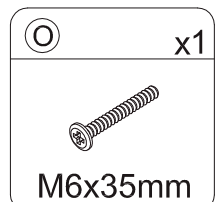
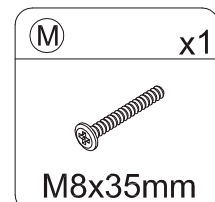
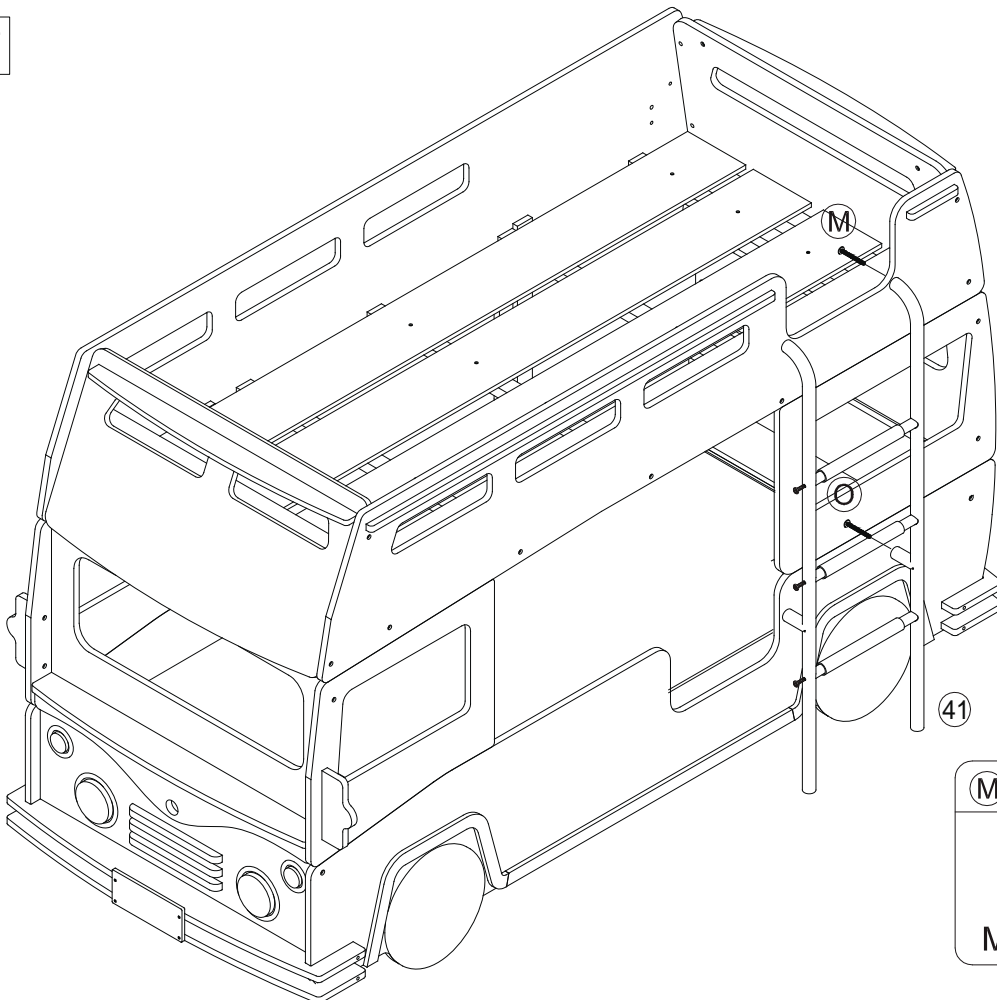

28

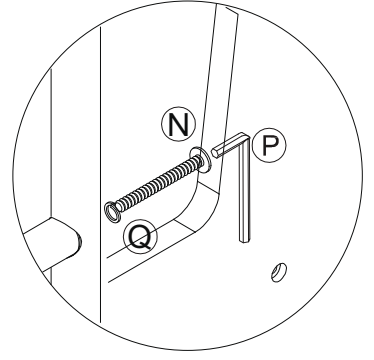
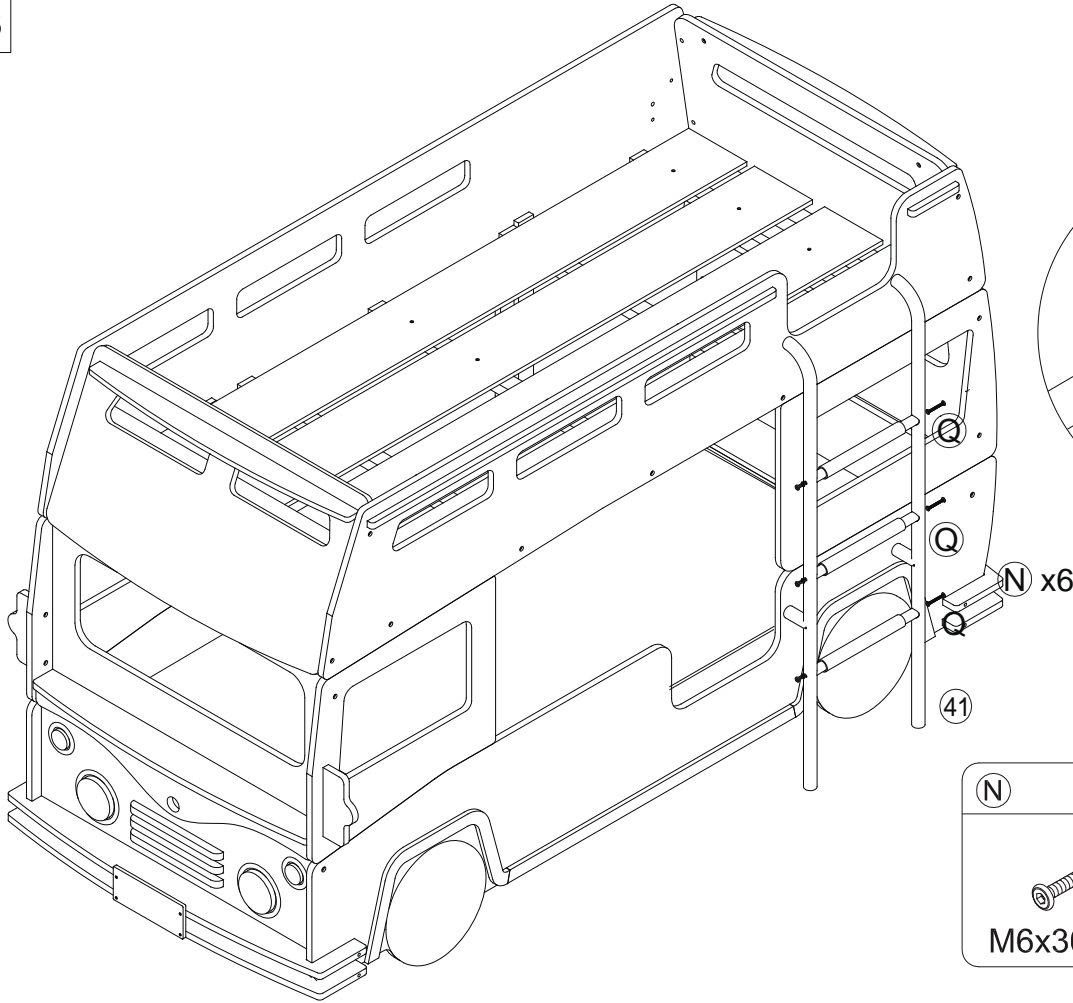

- N** x6
  - Q** x3
  - P** x1
- M6x30mm

29

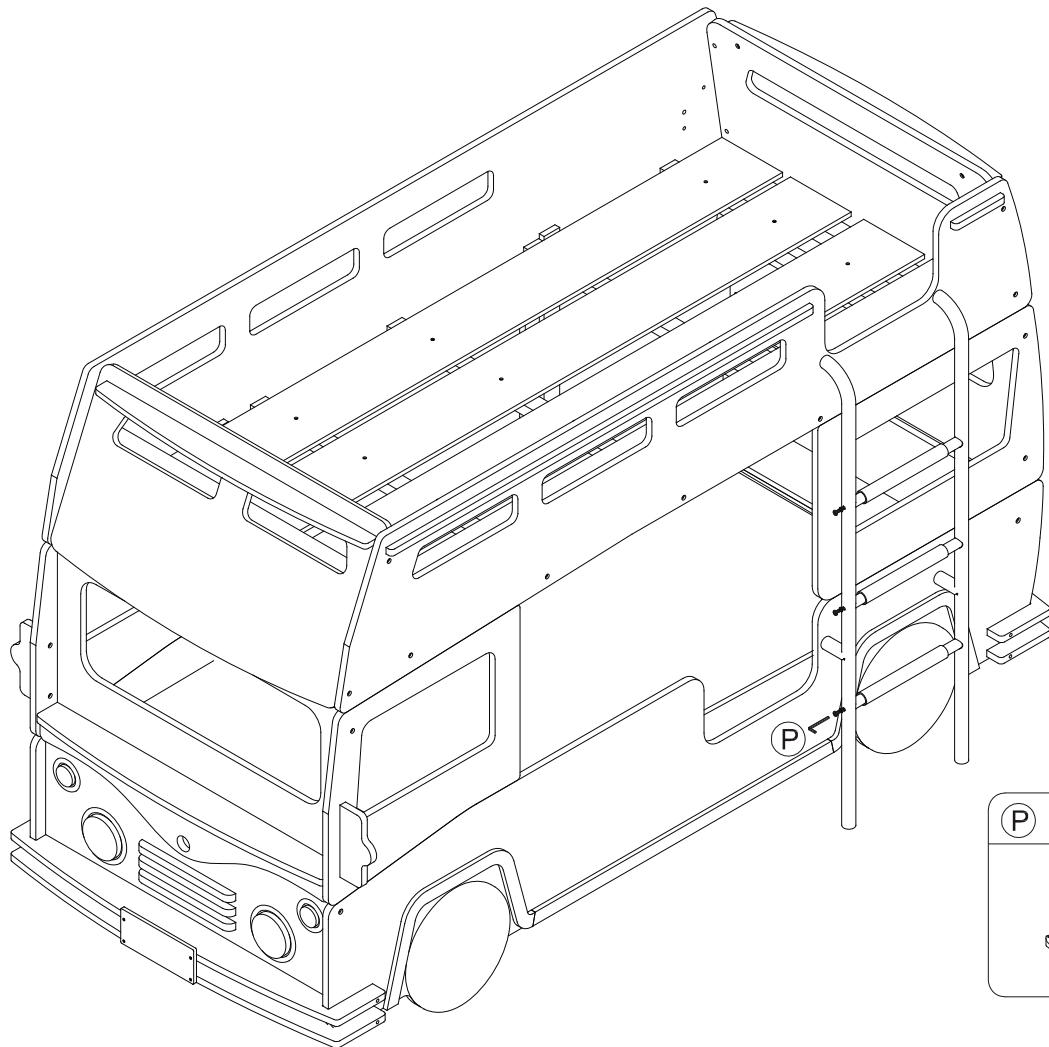

- P** x1

**END**

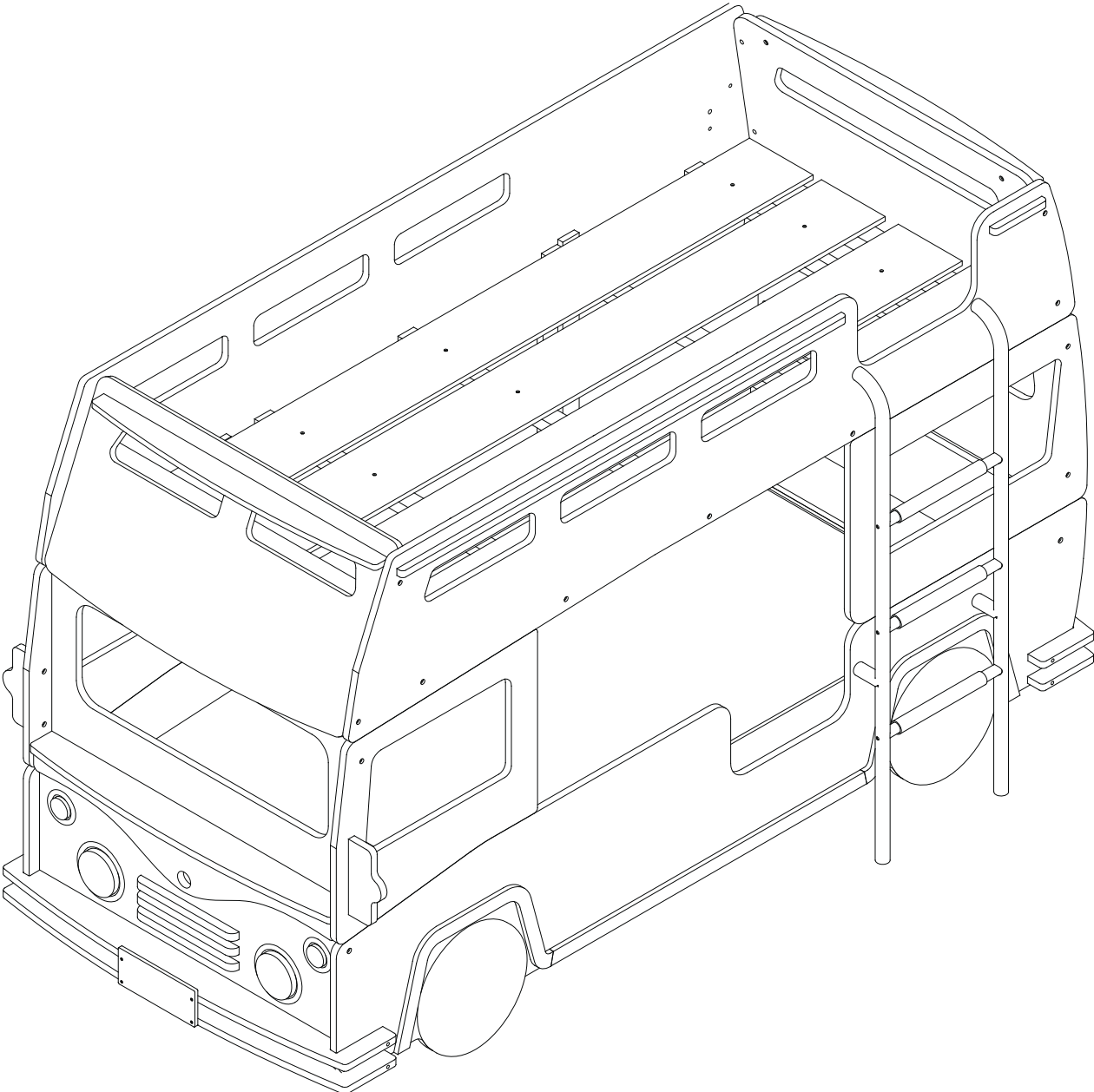

**SPANISH**

3325-02 08/04/2013

**IMPORTANTE - LEER ATENTAMENTE. CONSERVAR PARA REFERENCIA POST****DIMENSION DE COLCHON PARA ESTA CAMA : 90 X 200CM O 90 X 190 CM****LOS NINOS PUEDEN SER BLOQUEADOS ENTRE LA CAMA Y LA PARED, ENTONCES LA DISTANCIA ENTRE LOS 2 DEBE SER INFERIOR A 75MM O POR LO MENOS 230MM PARA SU SEGURIDAD.****CUIDADO CON LOS RIESGOS DE AHOGAMIENTO CON LOS OBJETOS FIJADOS EN LA CAMA****ITALIAN****IMPORTANTE - LEGGERE ATTENTAMENTE - DA CONSERVARE PER RIFERIMENTO ULTERIORE -****DIMENSIONE DEL MATERASSO RACCOMANDATA : 90x 200CM O 90 x 190 CM****I BAMBINI POSSONO RIMANERE INTRAPPOLATI TRA IL MURO E LA PARETE. PER EVITARE QUESTI RISCHI, LA DISTANZA TRA I DUE DEVE ESSERE INFERIORE A 75MM O ALMENO 230MM.****ATTENTO AI RISCHI DI STRANGOLAMENTO CON OGGETTI FISSATI SUL LETTO.****PORTUGUESE****IMPORTANTE - LER ATENTAMENTE - CONSERVAR PARA REFERENCIA ULTERIOR****TAMANHO DE COLCHAO RECOMENDADO 90 x 200CM OU 90 x 190 CM****AS CRIANCAS PODEM ENCONTRAR-SE BLOQUEADAS ENTRE A CAMA E A PAREDE. PARA EVITAR TAL COISA, A DISTANCIA TEM DE SER INFERIOR A 75MM OU PELO MENOS DE 230MM****CUIDADO COM OS RISCOS DE ESTRANGULAMENTO COM OBJECTOS FIXADOS NA CAMA.****DUTSH****OPGELET - AANDACHTIG LEZEN - TE BEWAREN VOOR LATERE REFERENTIE****AANBEVOLEN MATRASMAT 90 x 200CM OF 90 x 190 CM****KINDEREN KUNNEN KLEM KOMEN TE ZITTEN TUSSEN HET BED EN DE MUUR. OM DIT TE VERMIJDEN DIENT DE AFSTAND TUSSEN BED EN MUUR TEN HOOGSTE 75CM, EN MINSTENS 230MM TE BEDRAGEN.****OPGELET VOOR VERSTIKKINGSGEVAAR DOOR AAN HET BED BEVESTIGDE VOORWERPEN.****POLISH****WAŻNE - PRZECZYTAĆ UWAŻNIE I ZACHOWAĆ****ZALECANA WIELKOŚĆ MATERACA 90 x 200 CM O 90 x 190 CM****DZIECKO MOŻE SIĘ ZNALEŻĆ UWIĘZIONE MIĘDZY ŁÓŻKIEM A ŚCIANĄ. BY UNIKNAĆ RYZYKA DYSTANS MIĘDZY NIMI MUSI WYNOŚIĆ MNIEJ NIŻ 75 MM LUB WIĘCEJ NIŻ 230MM.****UWAGA NA RYZYKO UDUSZENIA PRZEDMIOTAMI PRZYWIĄZANYMI DO ŁÓŻKA.****GERMAN****Wichtig, aufmerksam lesen und aufbewahren****Die Grösse der Matratze muss 90 x 200 betragen Oder 90 x 190 CM****Die Kinder können sich zwischen dem Bett und der Wand einklemmen. Um diese Risiko zu vermeiden, muss der Abstand unter 75mm liegen oder höher als 230mm.****Achtung mit Teilen die am Bett befestigt sind, Erstickungsgefahr.****ENGLISH****IMPORTANT - PLEASE READ CAREFULLY - TO BE KEPT FOR FUTURE REFERENCE****MATRESS SIZE TO BE ADVISED 90 x 200CM OR 90 x 190 CM****CHILDREN COULD BE STUCKED BETWEEN THE BED AND THE WALL. TO AVOID THESE RISKS THE DISTANCE BETWEEN THEM SHOULD BE LESS THAN 75MM OR AT LEAST 230MM.****BE CAREFUL TO THE STRANGLING RISKS WITH ANY OBJECTS FIXED ONTO THE BED.****FRENCH****IMPORTANT - LIRE ATTENTIVEMENT. A CONSERVER POUR REFERENCE ULTERIEURE****TAILLE DE MATELAS RECOMMANDEE 90 x 200CM OU 90 x 190 CM****LES ENFANTS PEUVENT SE RETROUVER PIEGES ENTRE LE LIT ET LE MUR. POUR EVITER SES RISQUES LA DISTANCE ENTRE LES DEUX DOIT ETRE INFERIEURE A 75MM OU AU MOINS 230MM.****ATTENTION AUX RISQUES D'ETRANGLEMENT AVEC DES OBJETS FIXES SUR LE LIT.**