

Model : 5001727

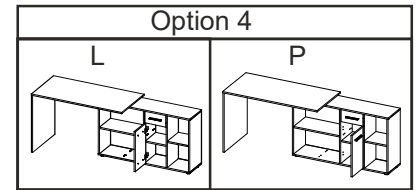

- | | |
|--------------------------------|------------------------------|
| D Montageanleitung | GB Assembly instruction |
| NL Handleiding voor de montage | PL Instrukcja montażu |
| TR Montaj talimatı | RU Инструкция по монтажу |
| FR Instructions de montage | IT Istruzioni di montaggio |
| CZ Montážní návod | RO Instrucțiuni de asamblare |
| HU Összeszerelési útmutató | SK Montážny návod |

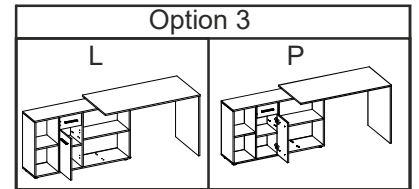
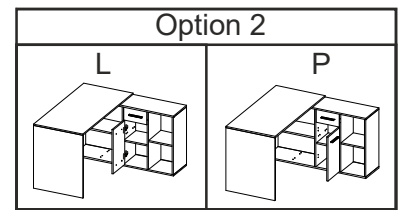
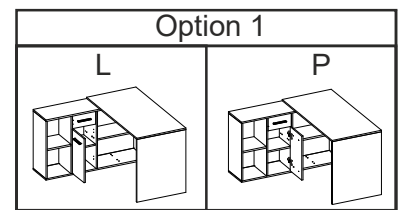
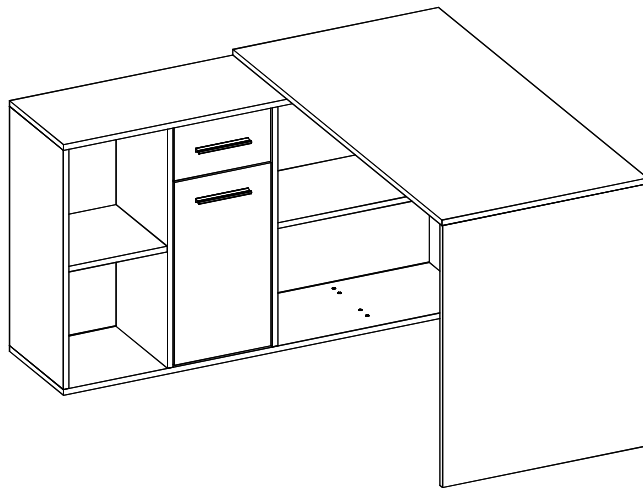
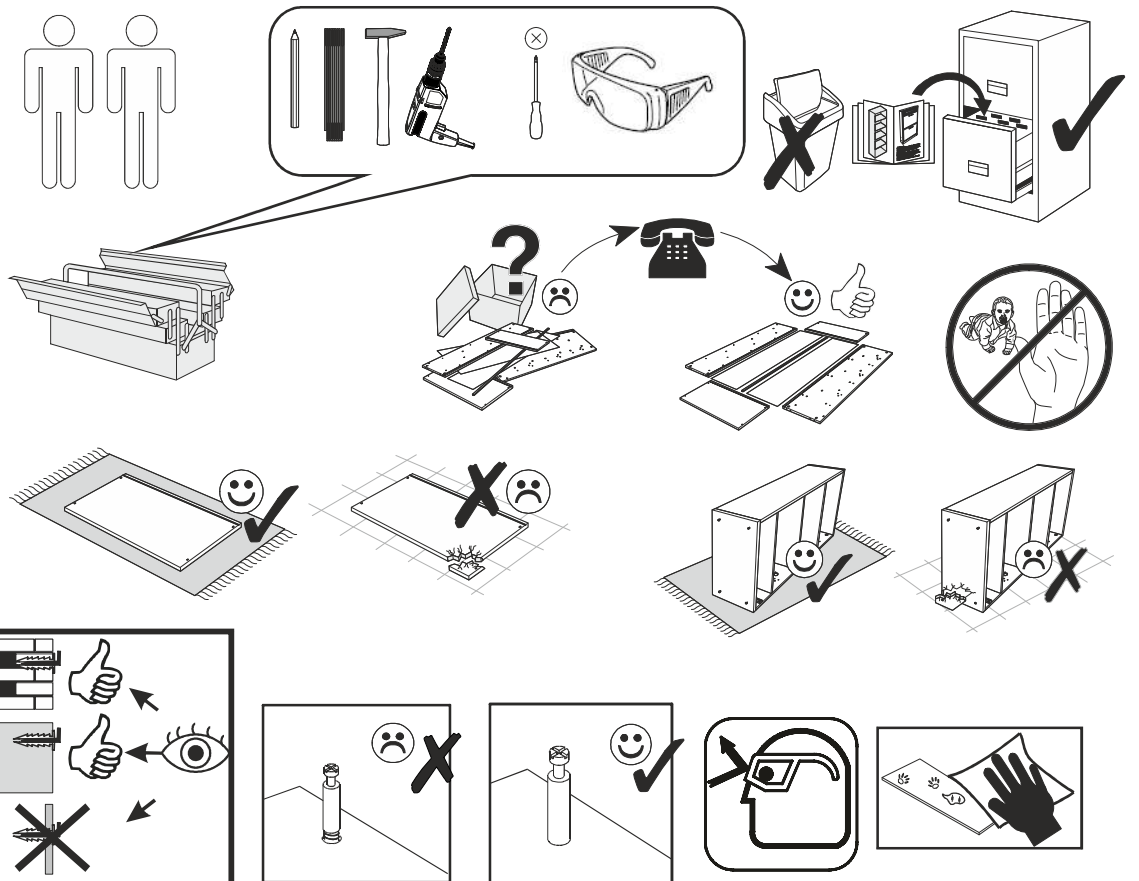

Service • Assistenza • Dienstverlening • Serwis • Servis • Szerviz • Сервисная сл ужба

Name • Nom • Nome • Naam Nazwa • Jméno • Názov • Név Denumire • Ísim • Название	5001727
Nr. No. • N° Номер • Č • Sz Typ • Type • Tip • Típus • Típo • Тип	Biurko

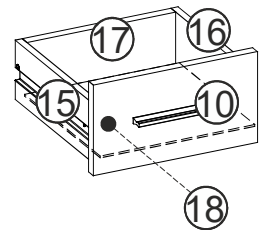
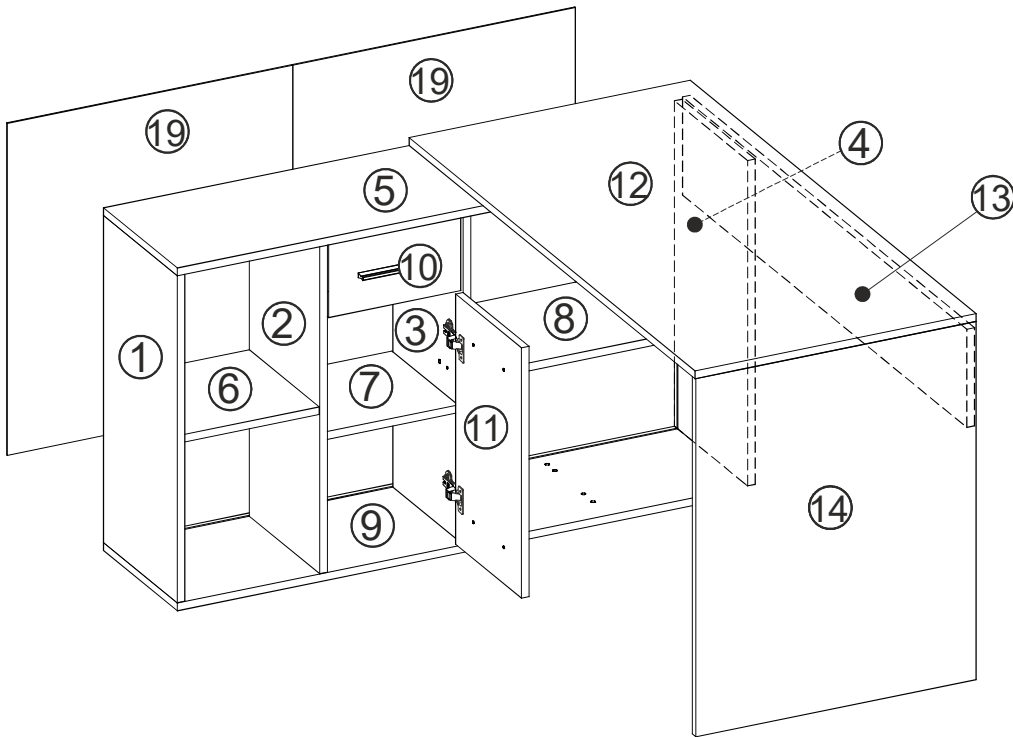
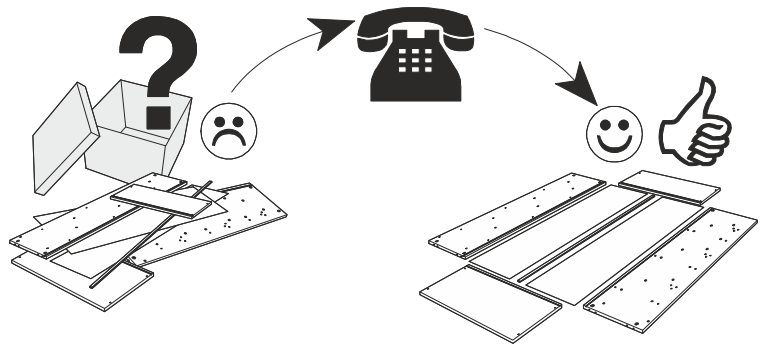
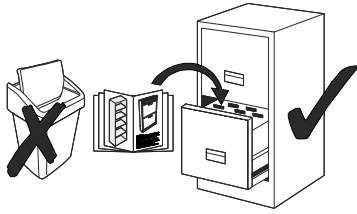

a0 6x30 x...(x4)	a1 8x35 x...(x28)	b x...(x2)	b02 x...(x2)	b3 x...(x2)	c2 Euro 6,3x13 x...(x4)	d1 x...(x4)				
e0 x...(x25)	e1 x...(x25)	f1 x...(x25)	g1 7x50 x...(x10)	h1 x...(x2)	k3 6.3x45 x...(x4)	k5 4x9 x...(x2)	k9 4x27 x...(x4)	m x...(x1)		
n1 3,5x16 x...(x4)	n3 3x20 x...(x6)	n4 x...(x5)	o2 x...(x2)	o18 x...(x5)	p0 n5 x...(x14)	p8 n8 x...(x16)	p9 x...(x4)	r1 x...(x6)	r4 x...(x12)	s x...(x1)



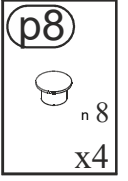
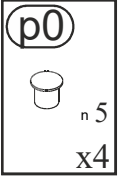
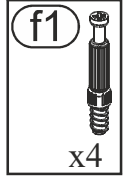
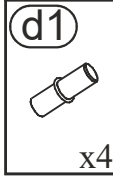
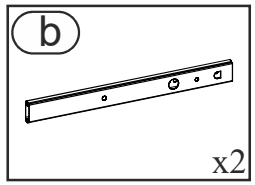
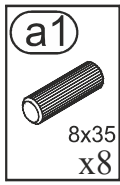
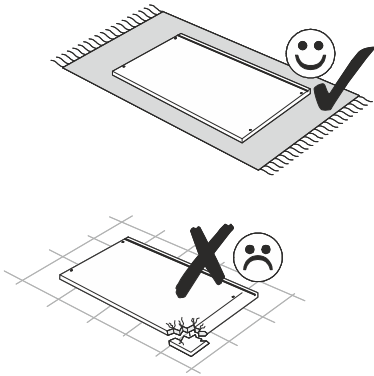

1

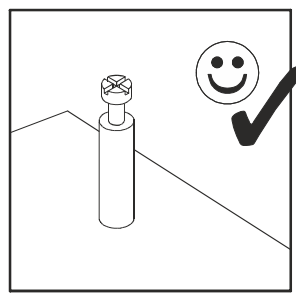
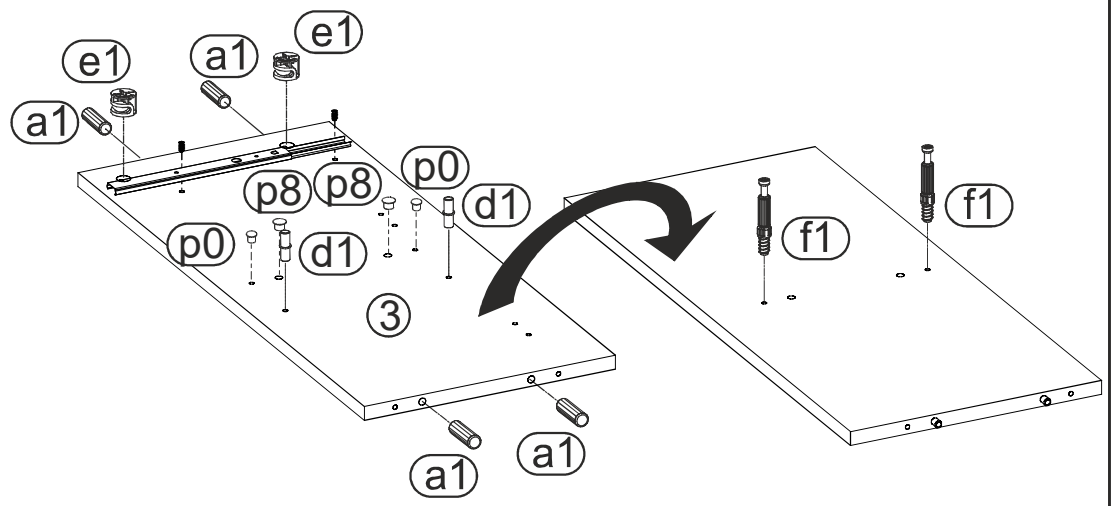
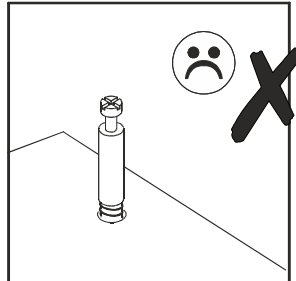
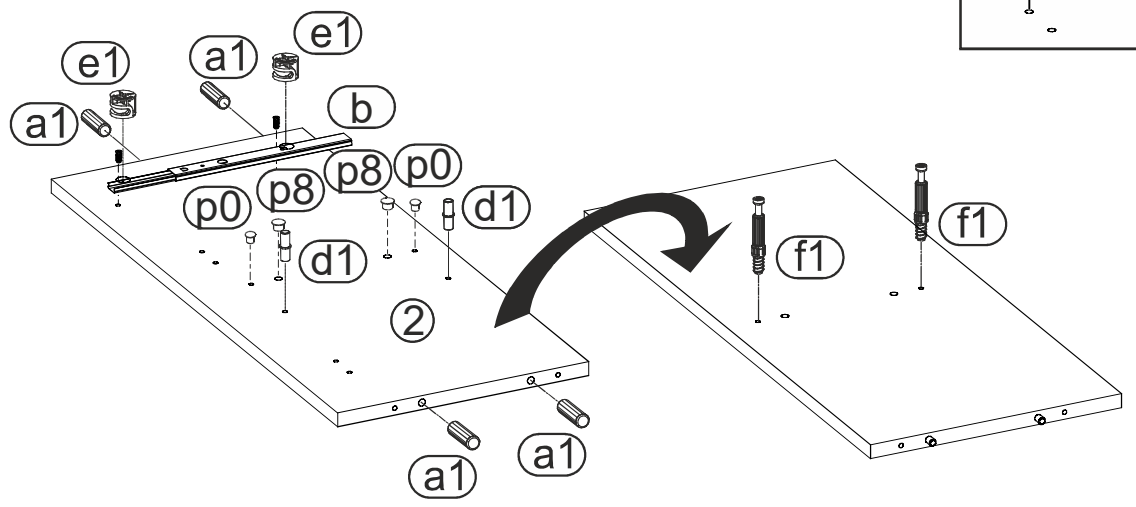
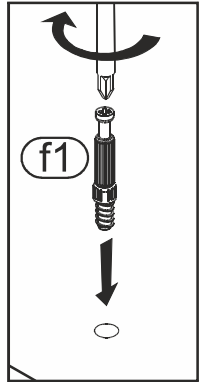
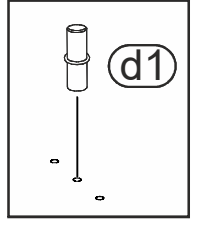
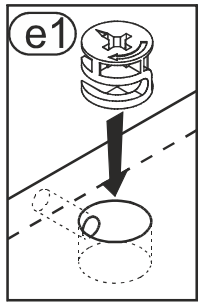
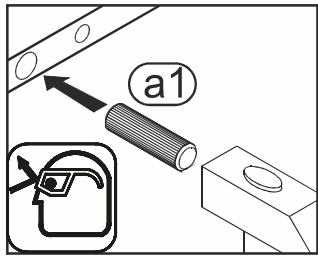
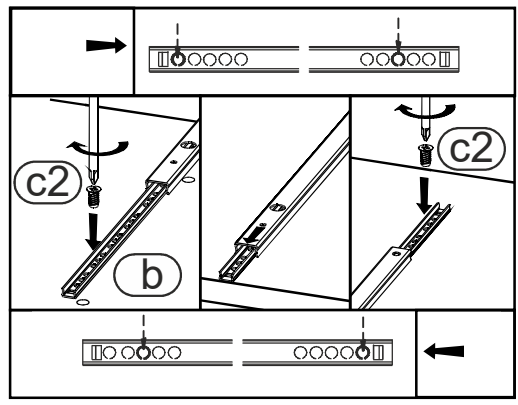

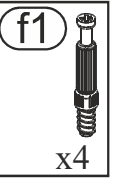
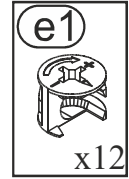
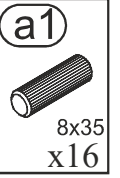
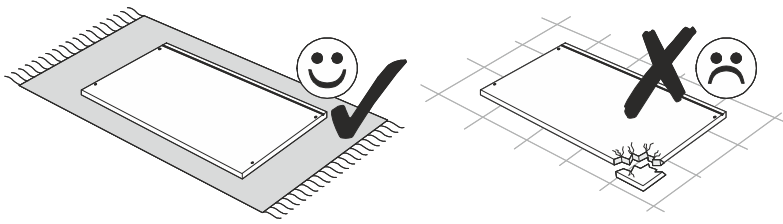

2

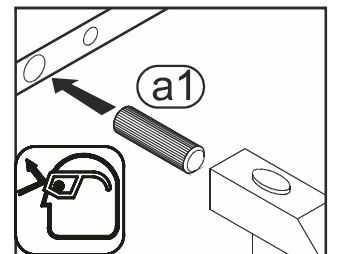
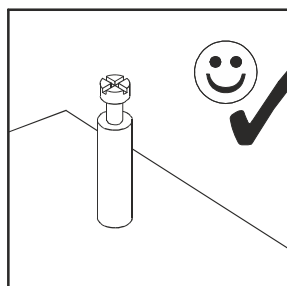
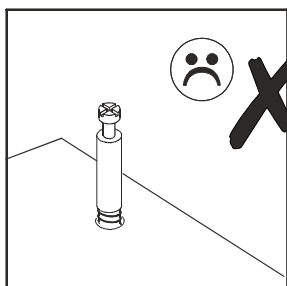
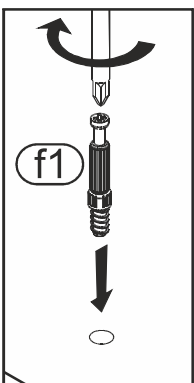
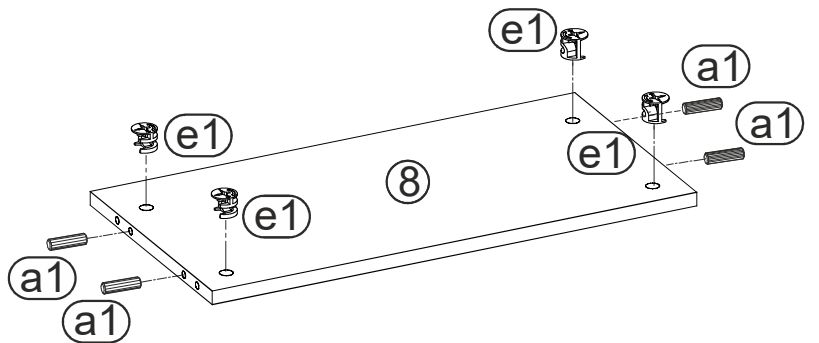
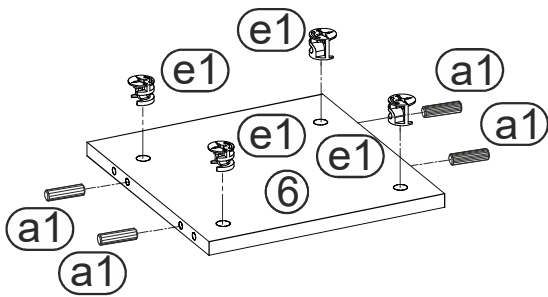
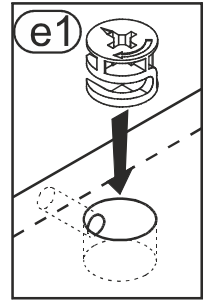
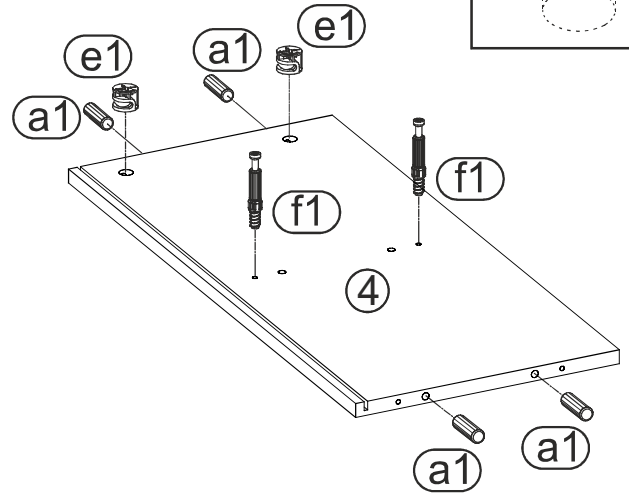
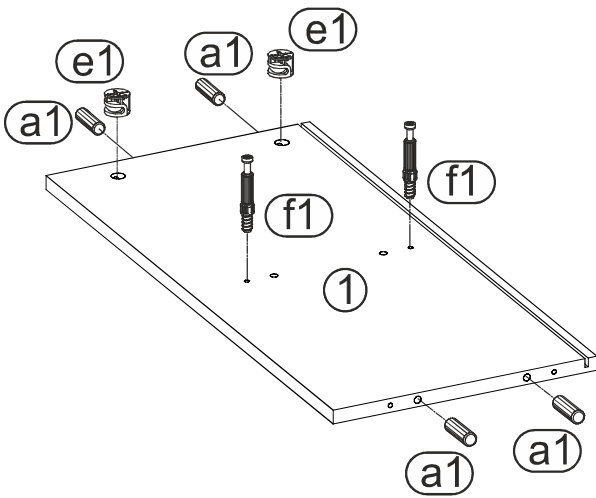

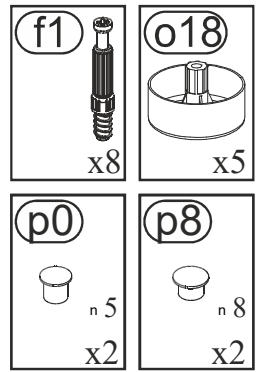
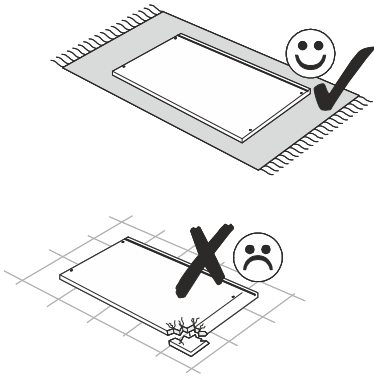

3

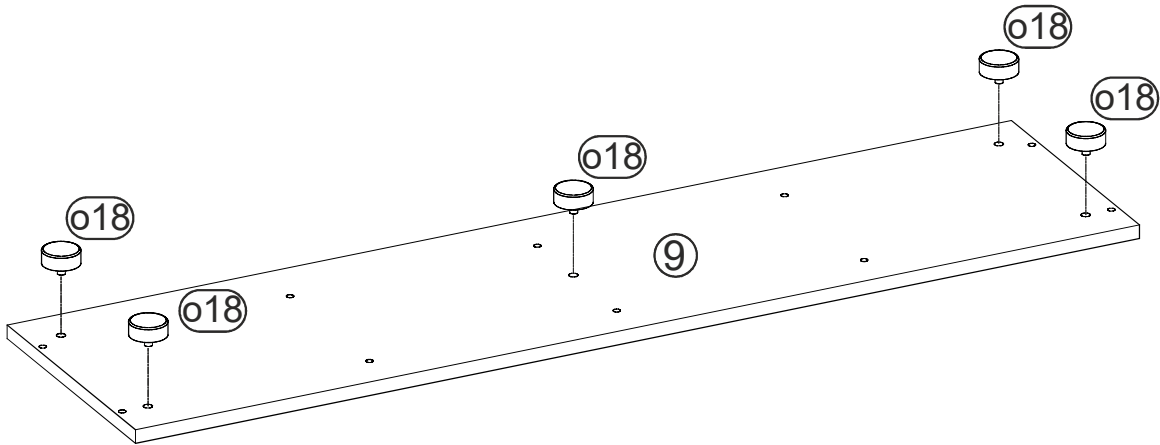

4

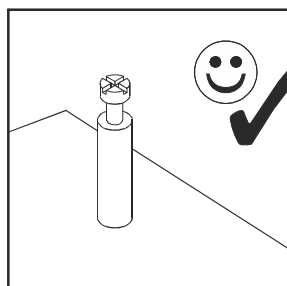
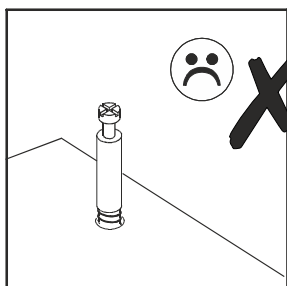
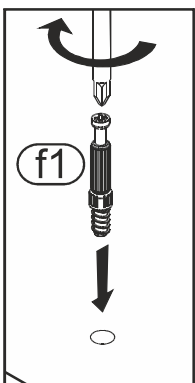
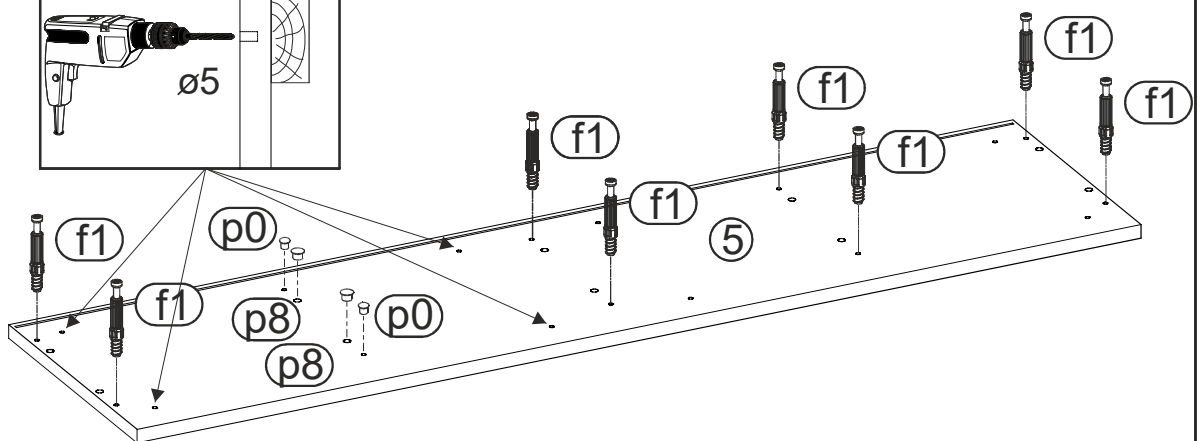
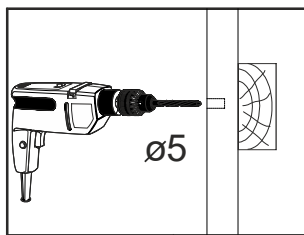
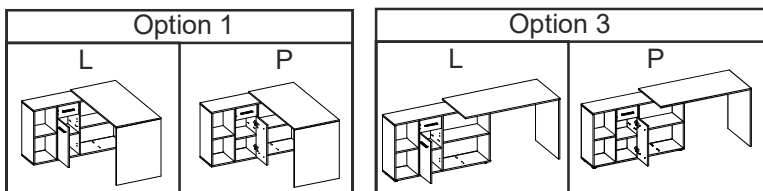

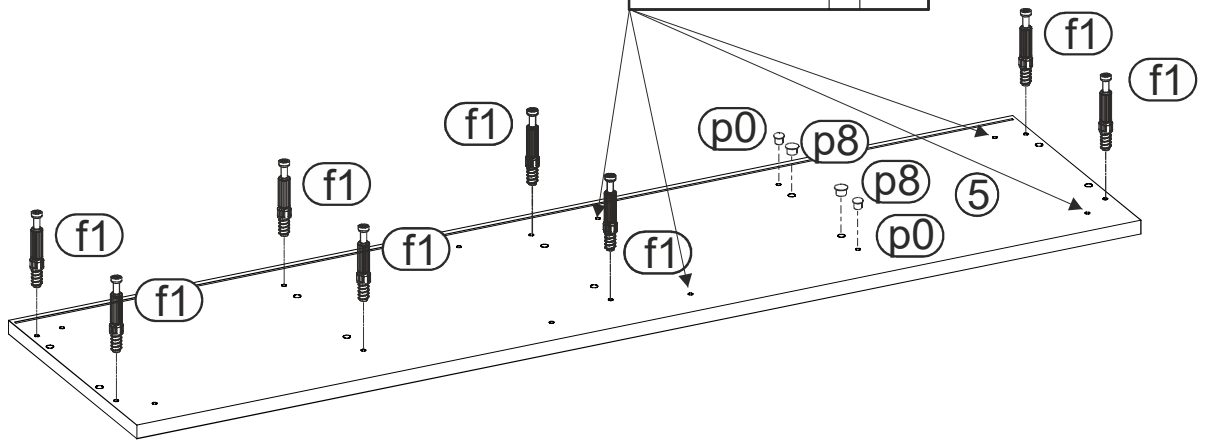
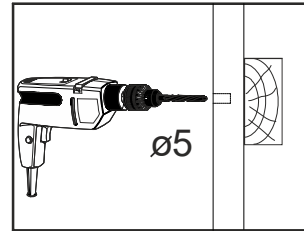
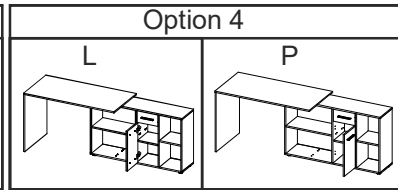
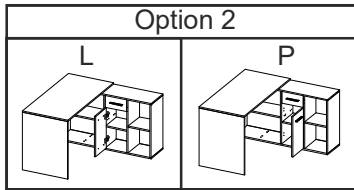
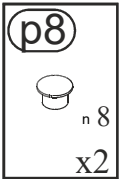
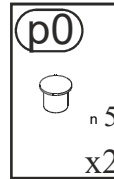
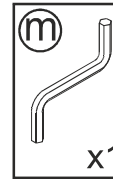
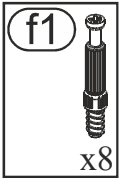
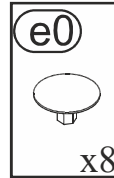
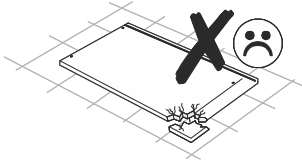
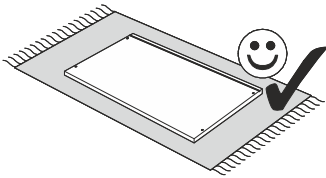

5

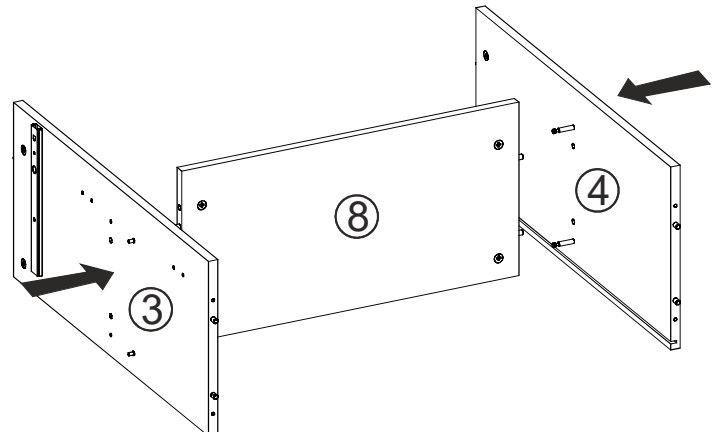
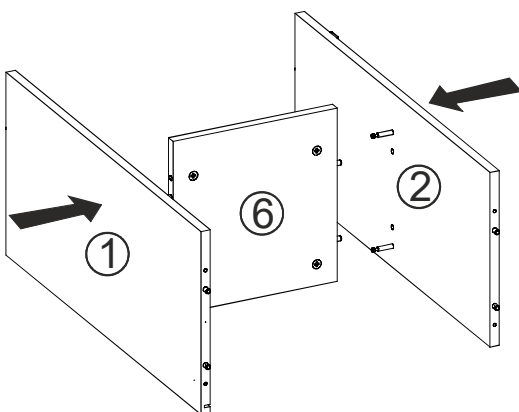
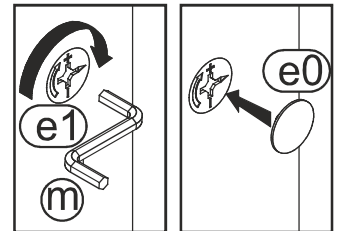
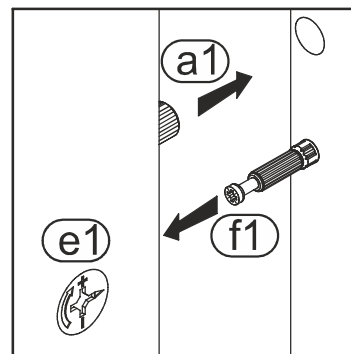
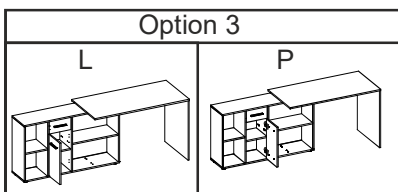
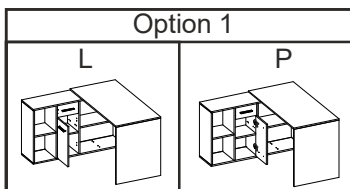

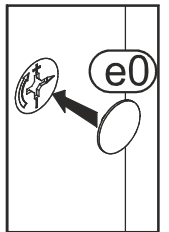
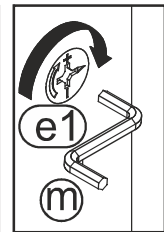
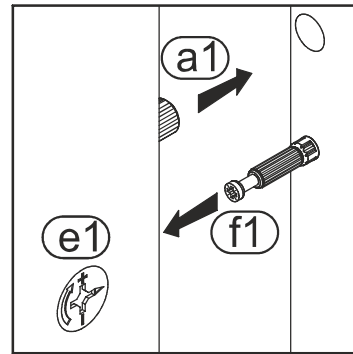
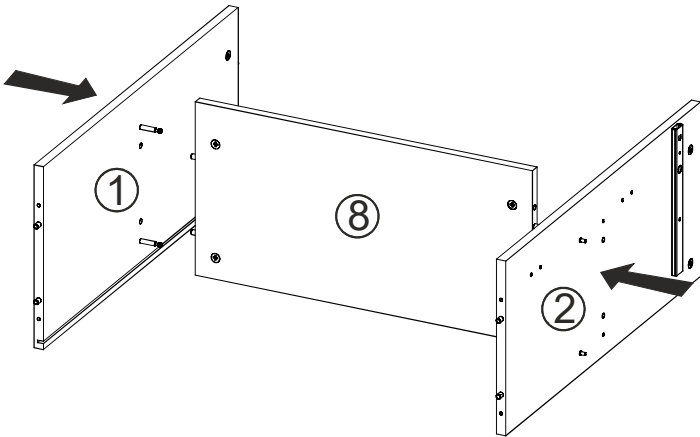
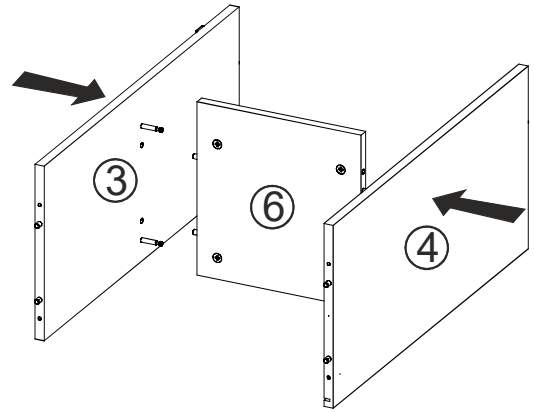
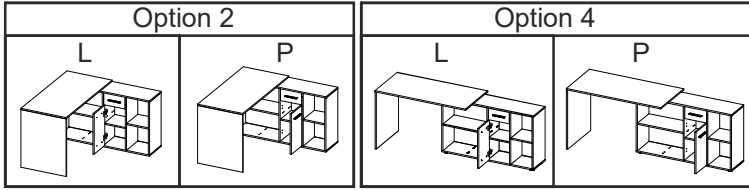
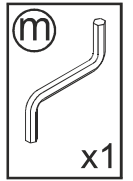
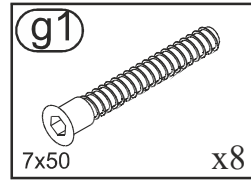
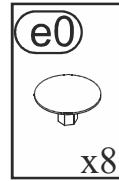
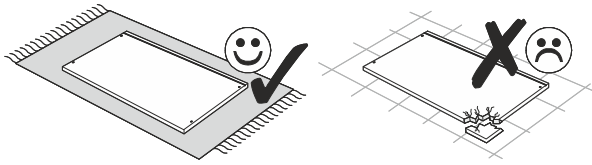

6

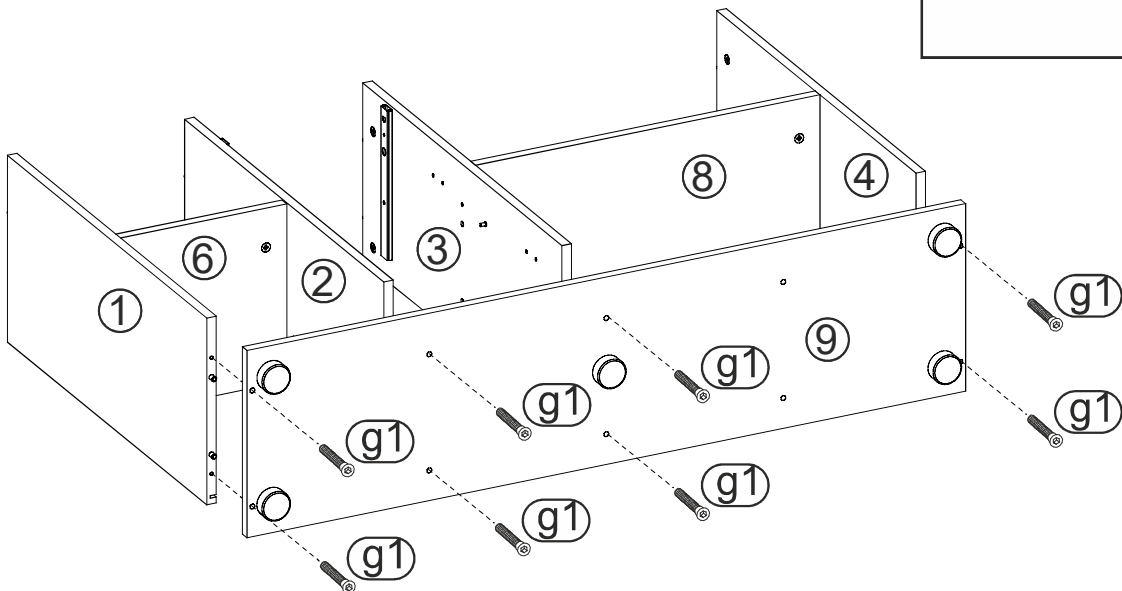
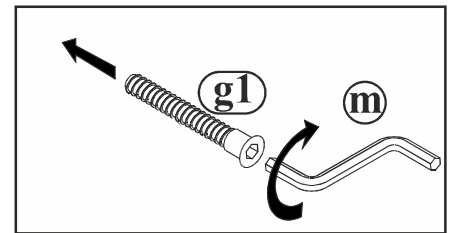
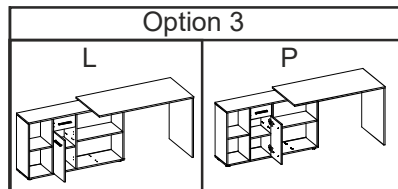
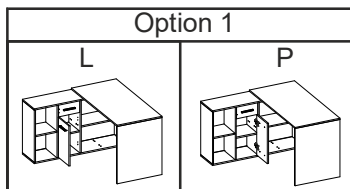

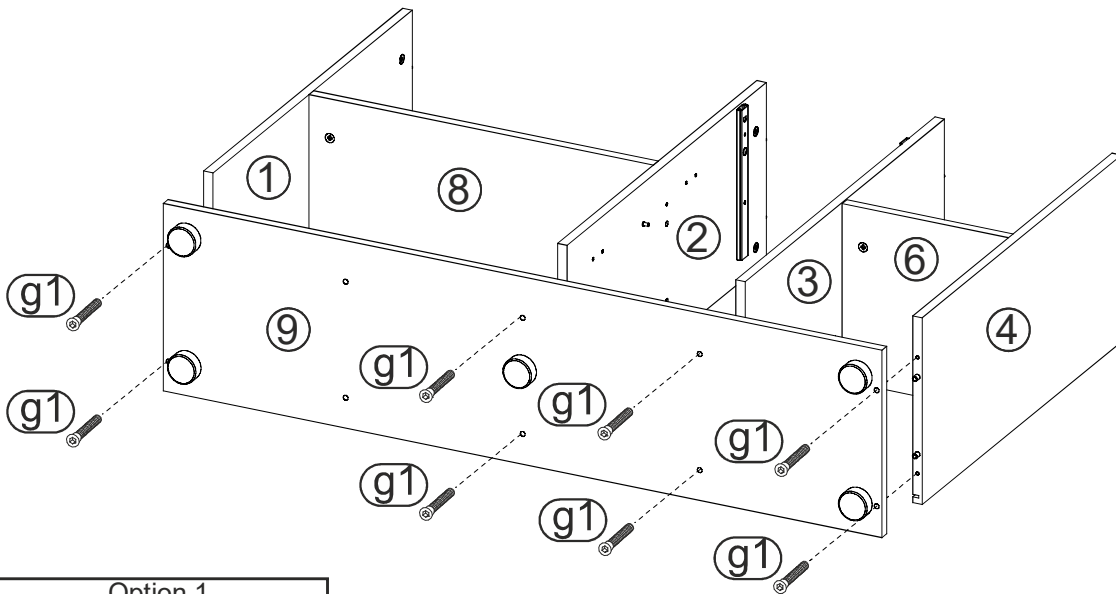
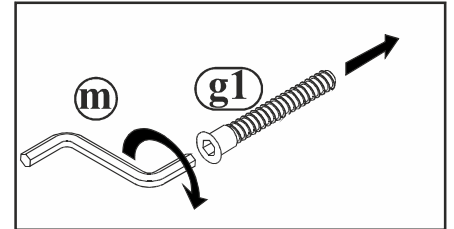
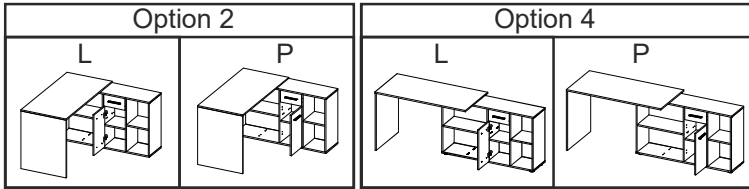
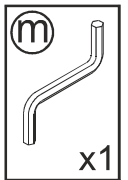
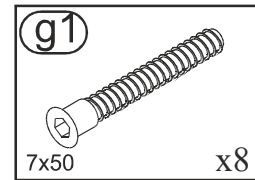
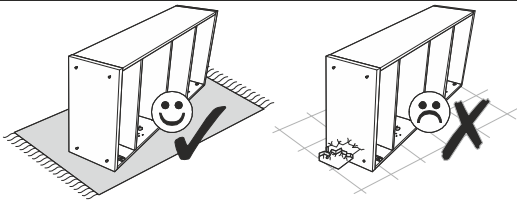

7

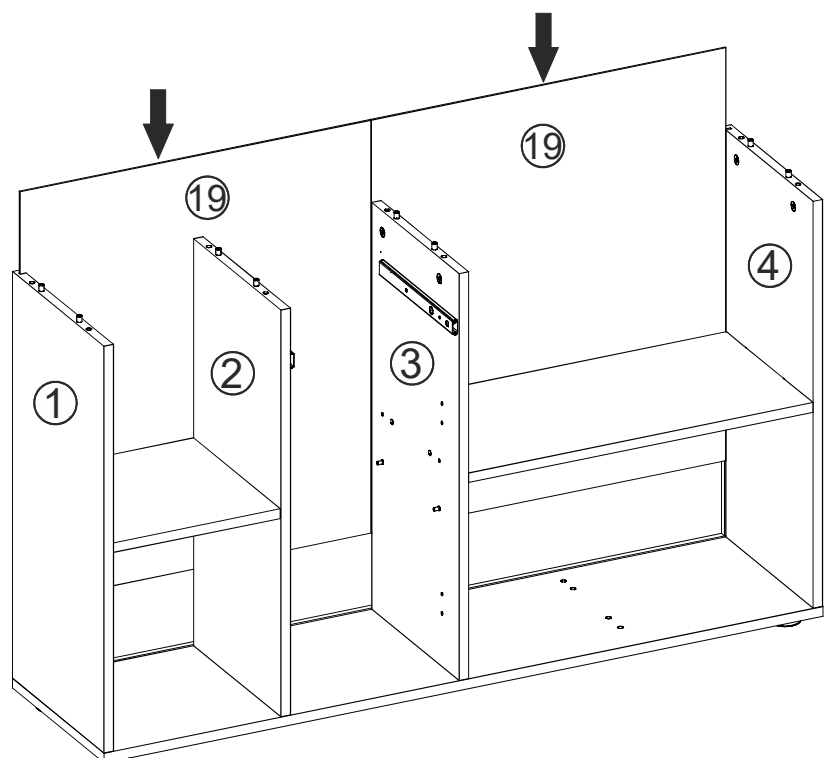
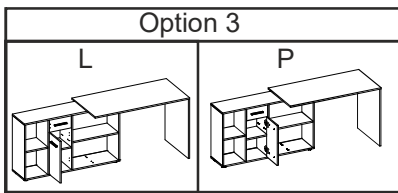
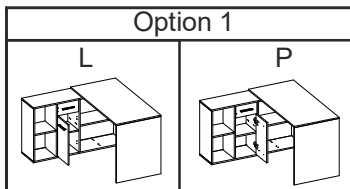

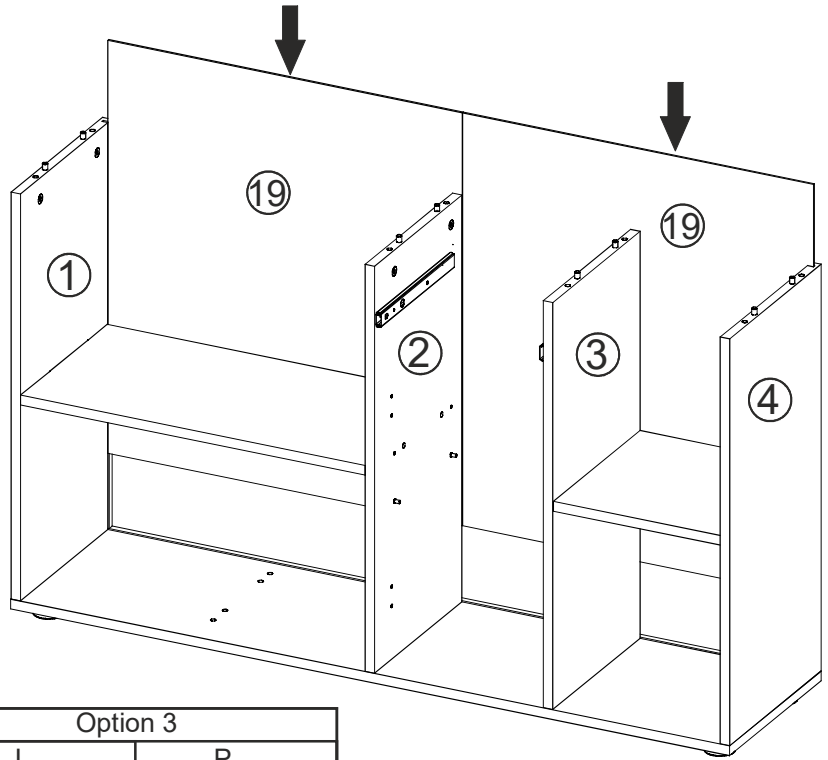
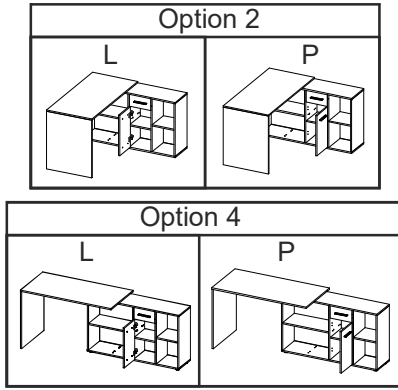
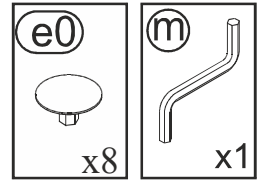
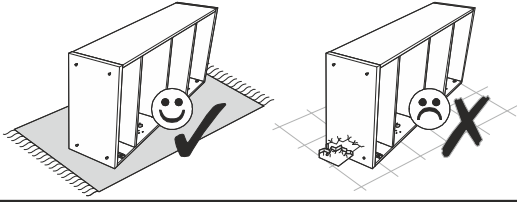

8

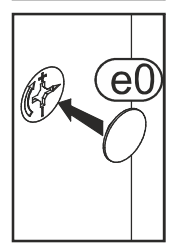
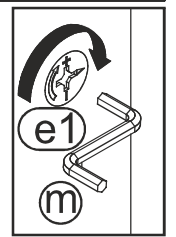
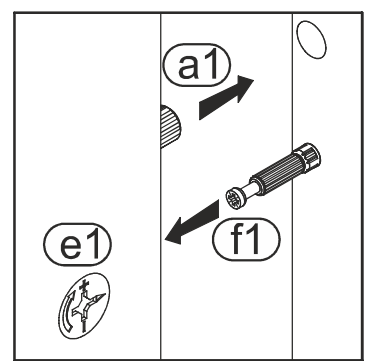
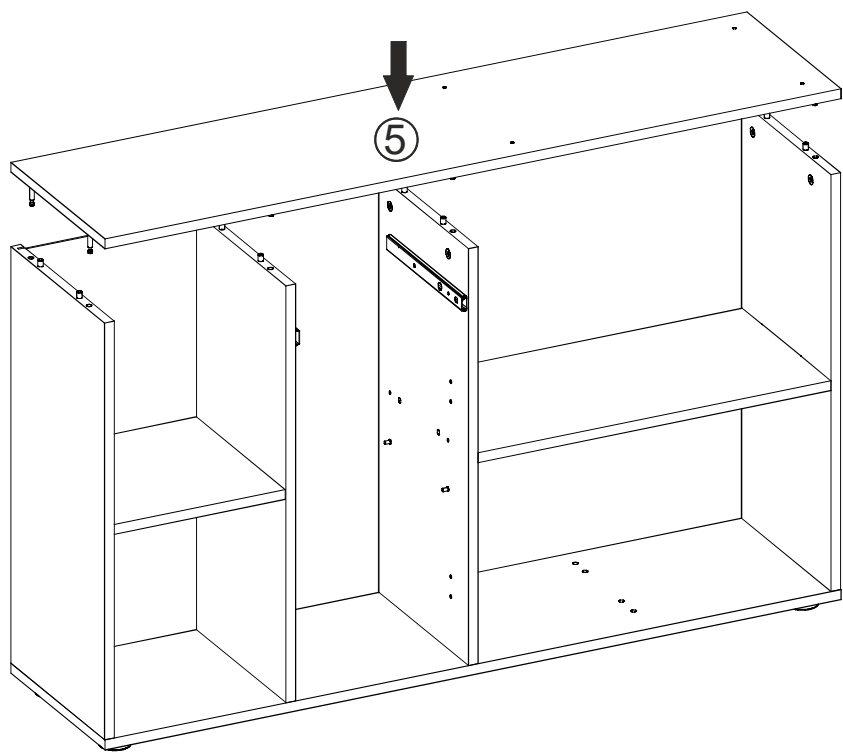
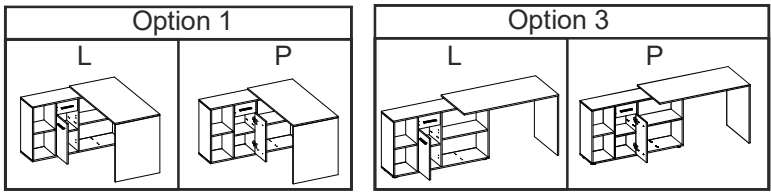

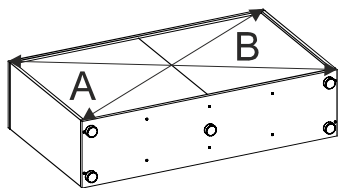
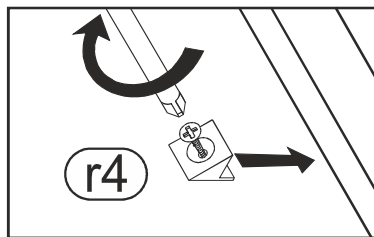
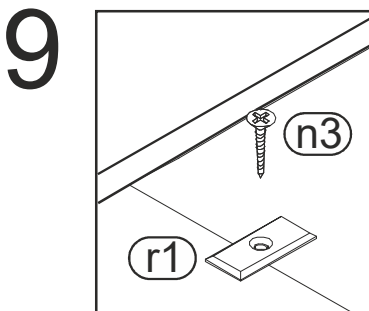
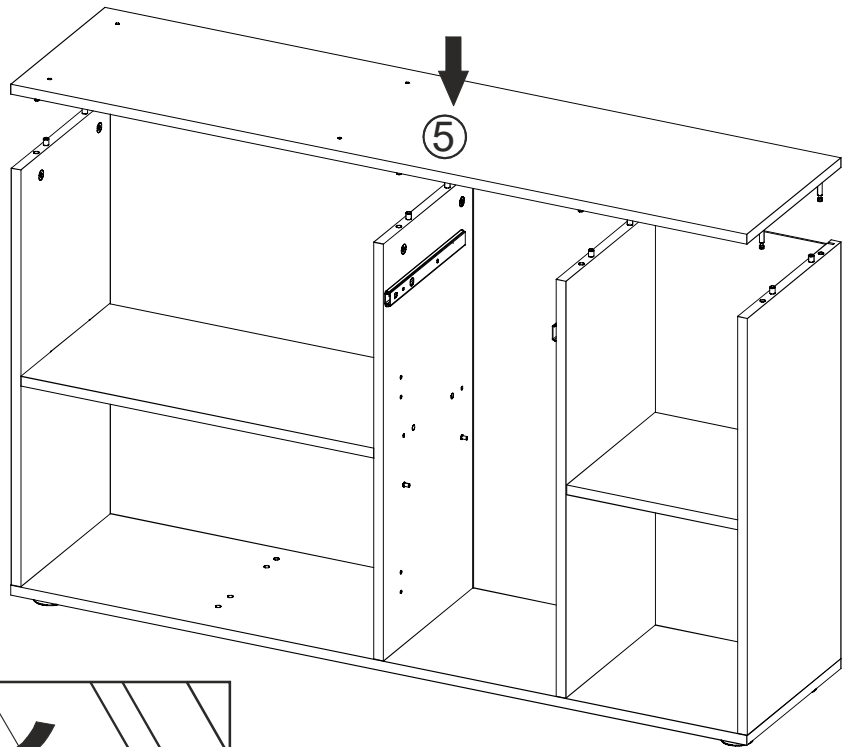
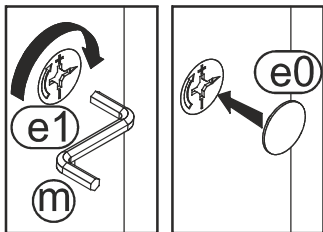
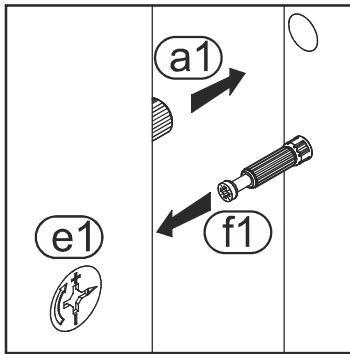
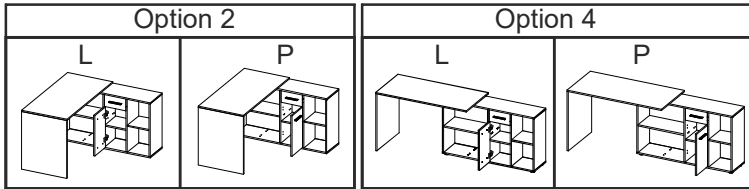
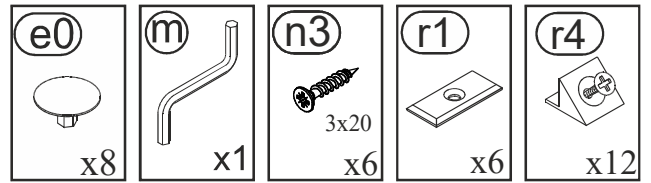
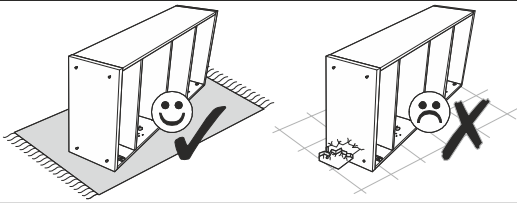

A=B

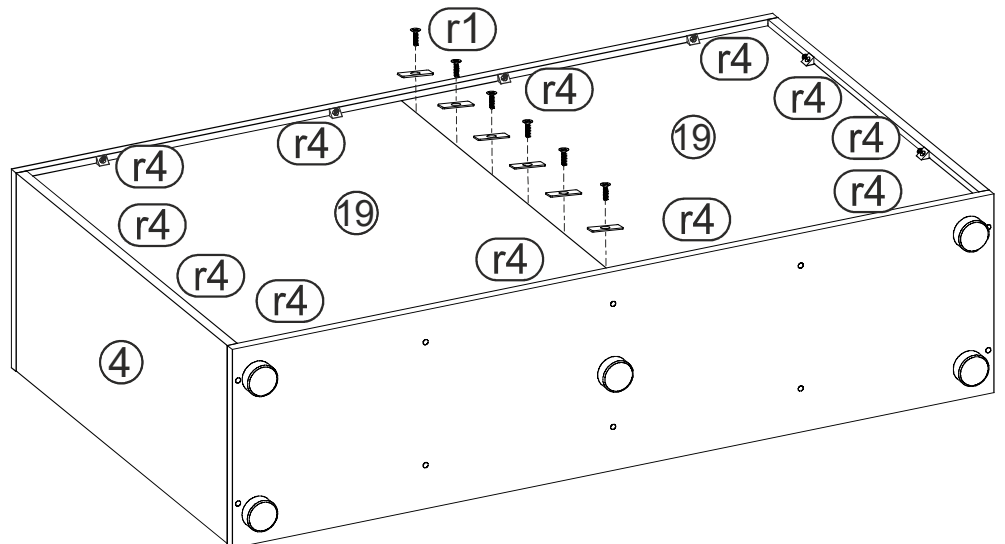

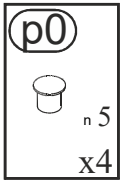
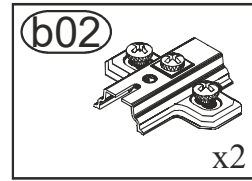
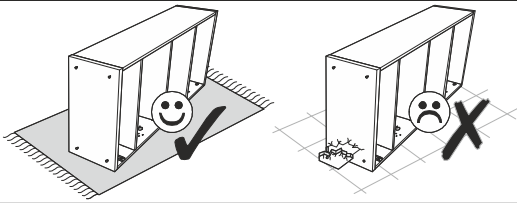

10

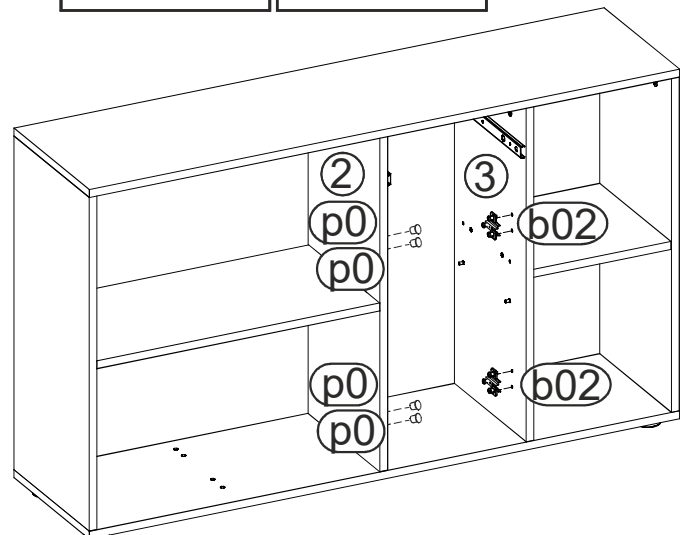
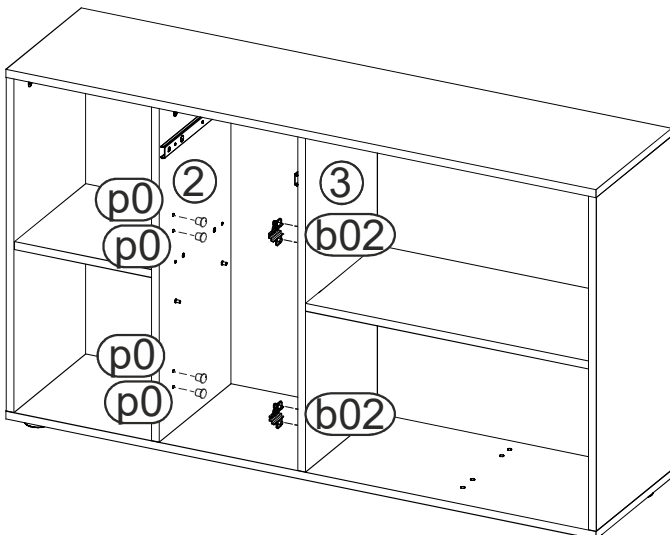
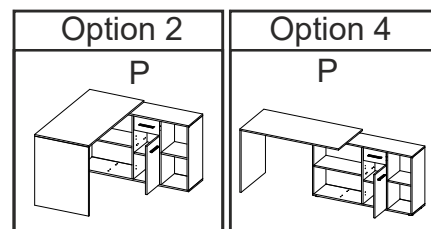
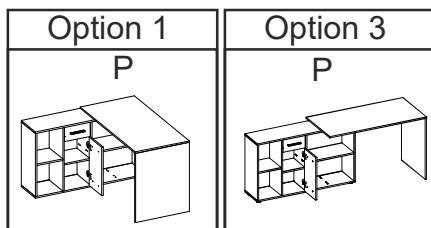
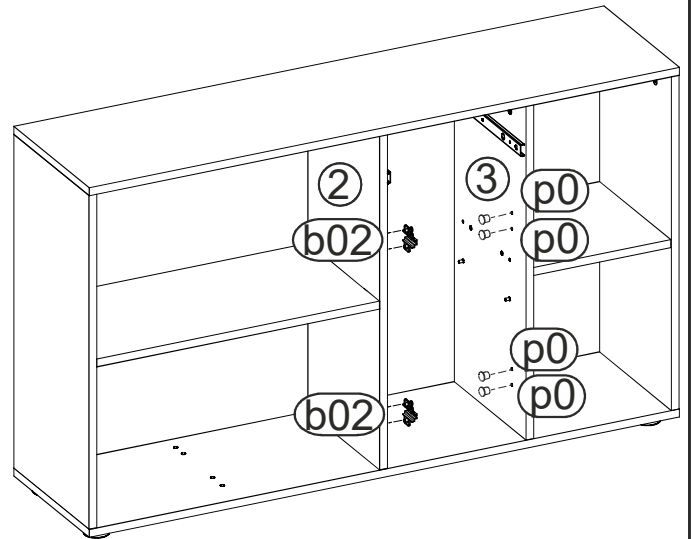
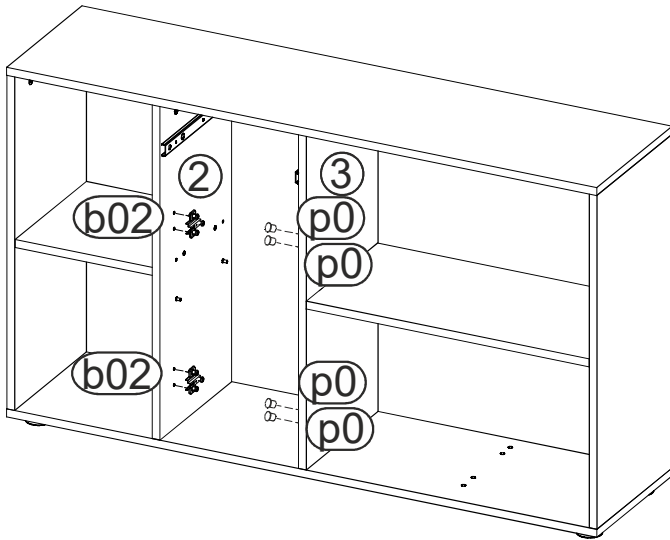
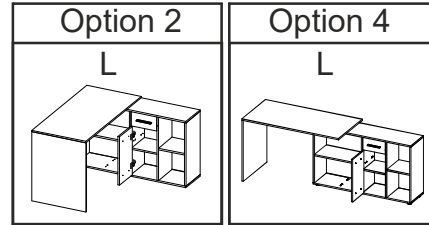
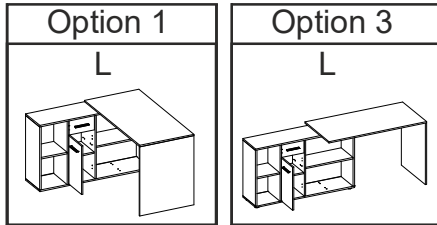

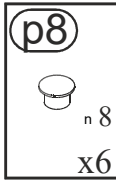
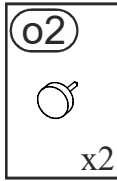
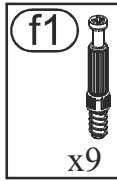
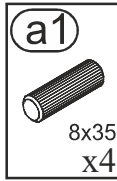
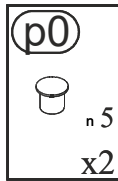
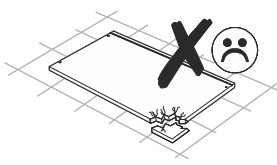
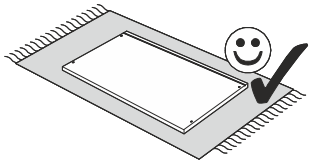

11

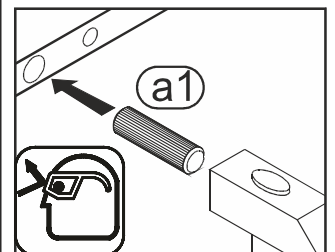
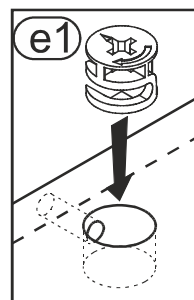
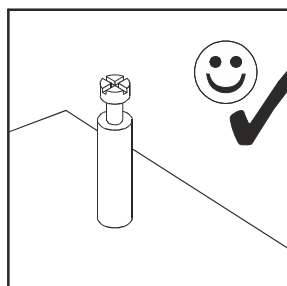
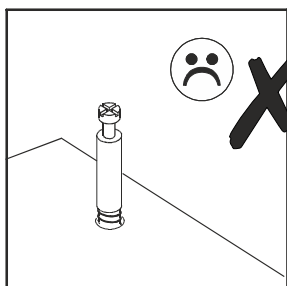
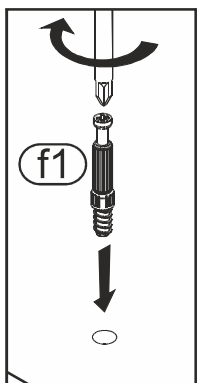
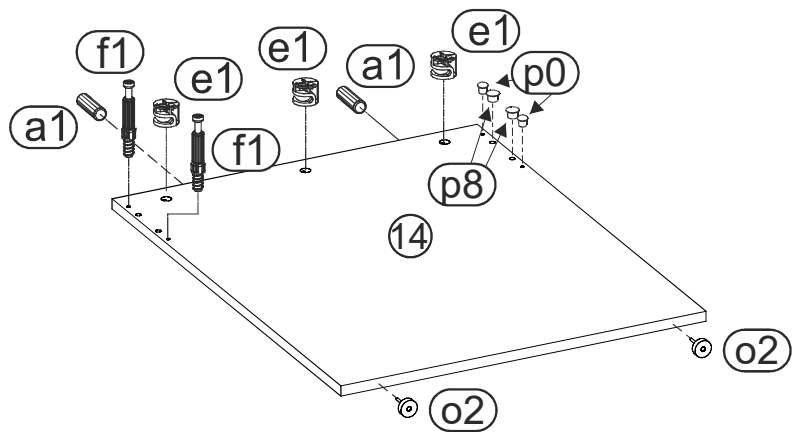
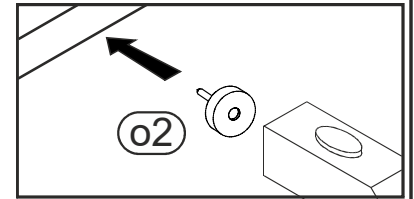
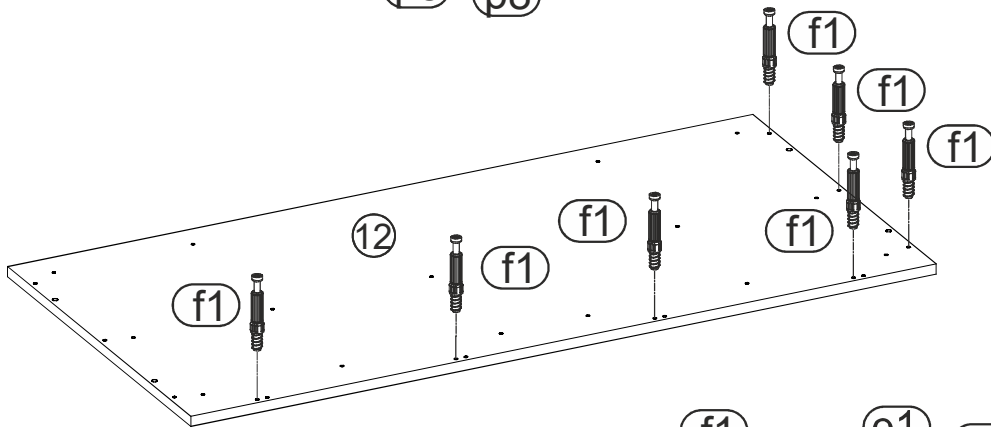
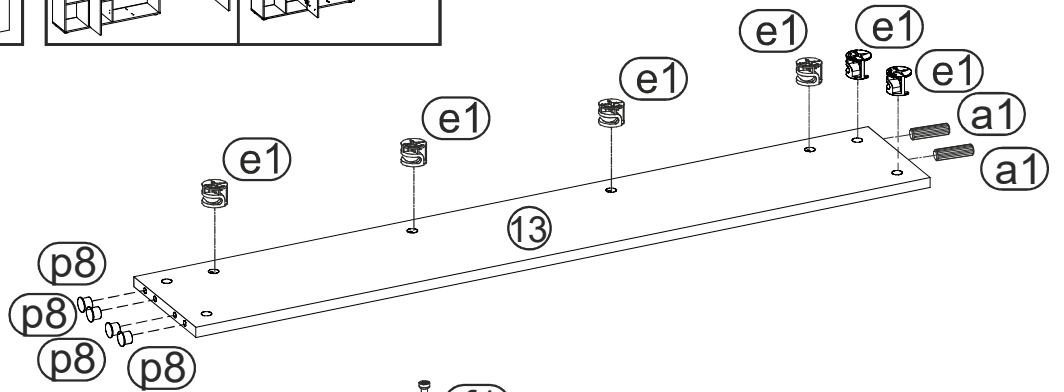
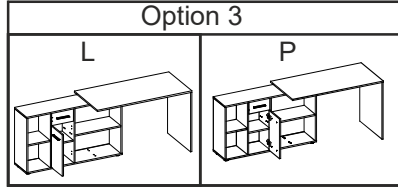
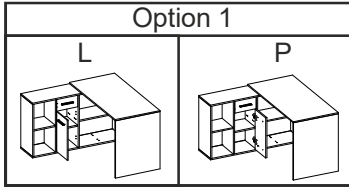

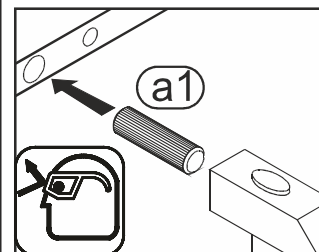
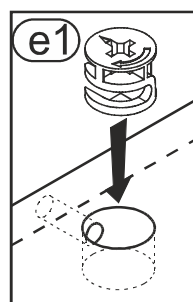
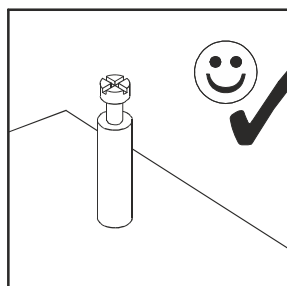
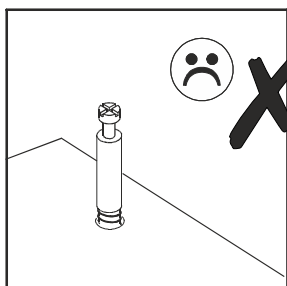
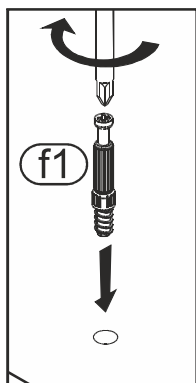
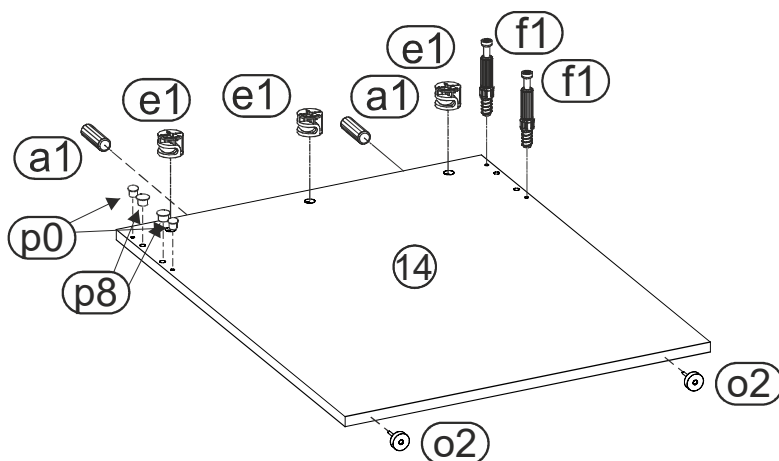
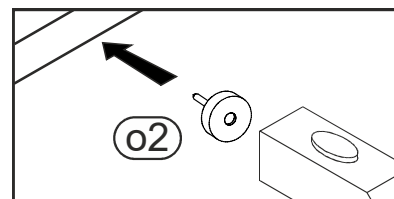
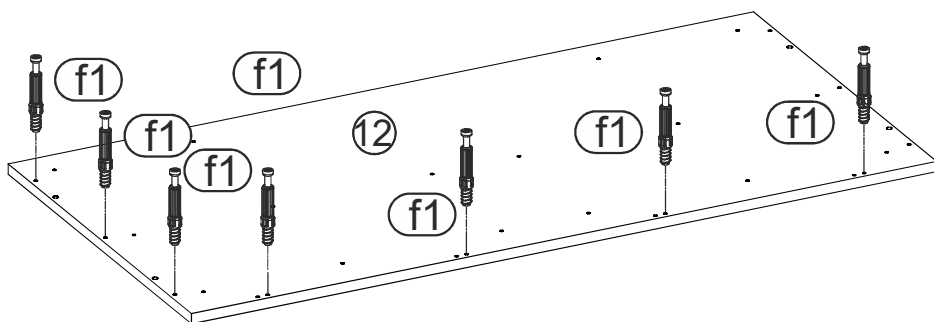
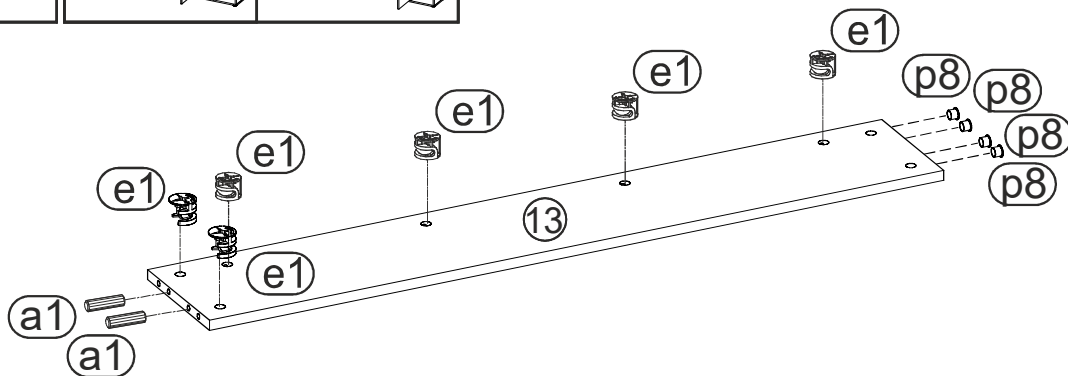
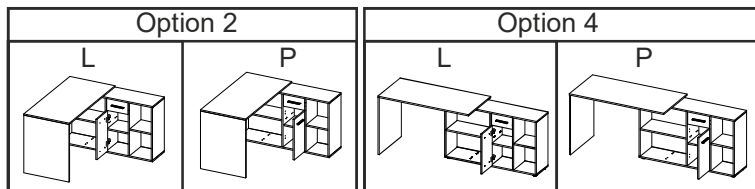
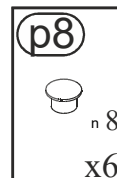
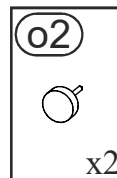
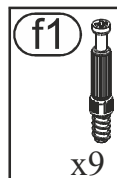
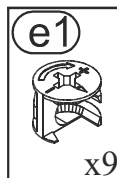
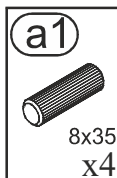
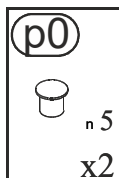
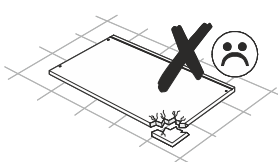
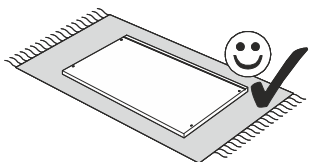

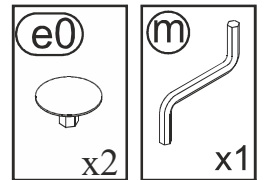
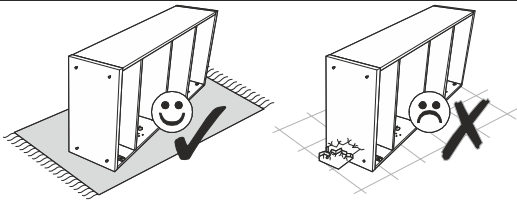

12

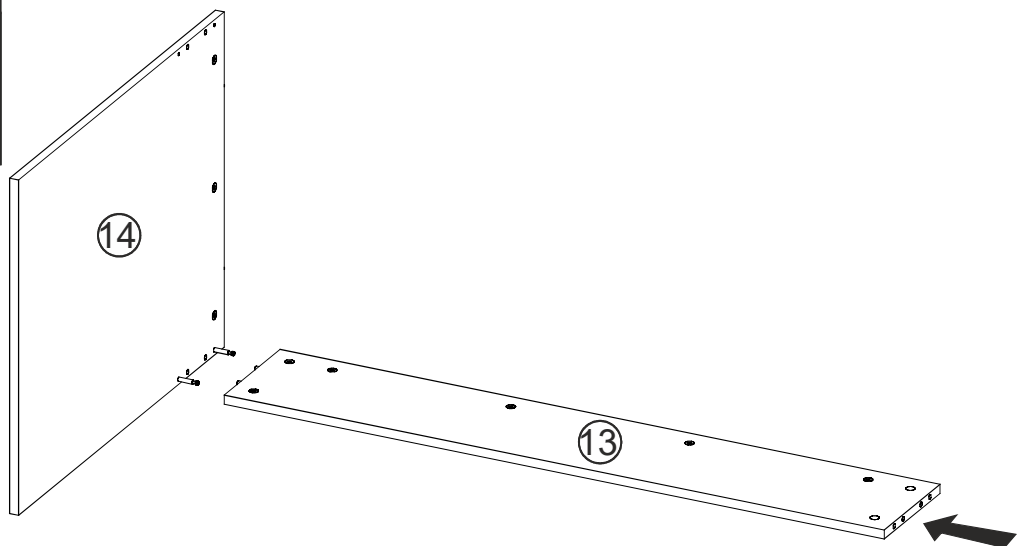
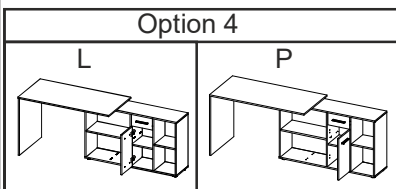
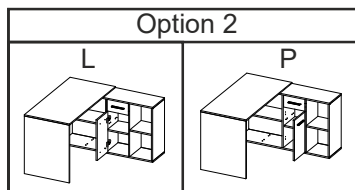
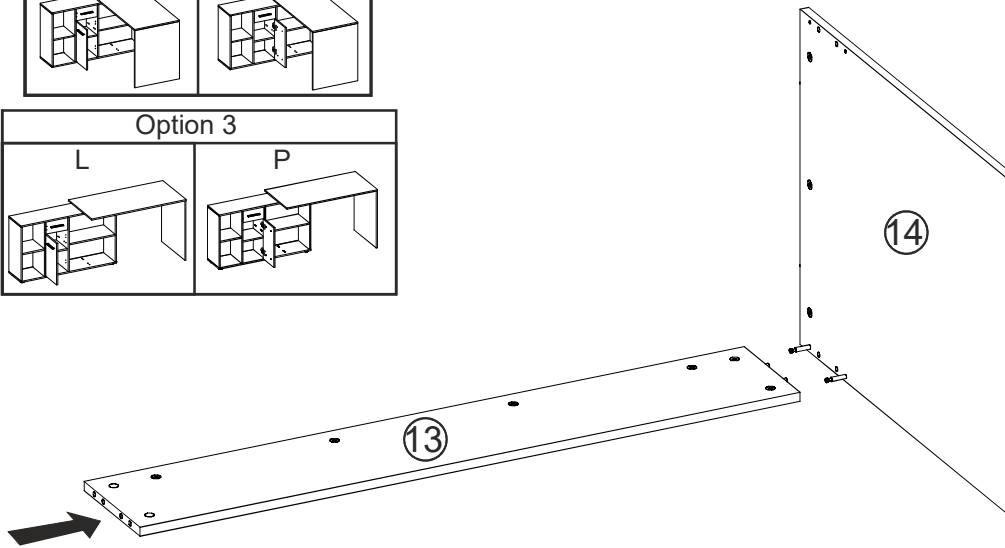
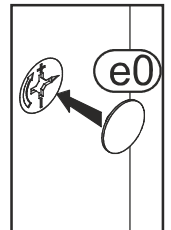
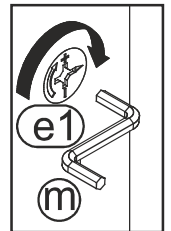
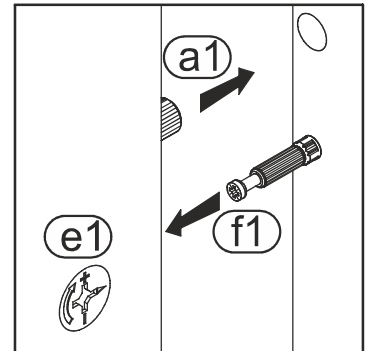
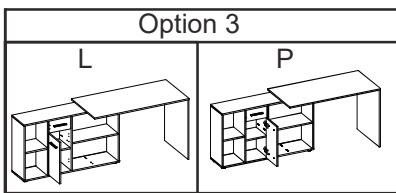
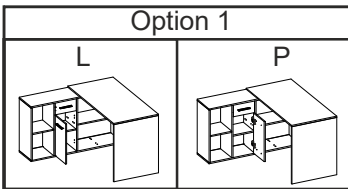

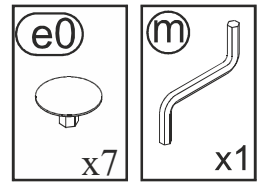
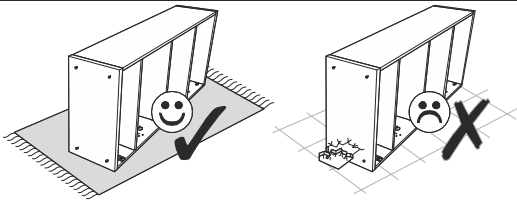

13

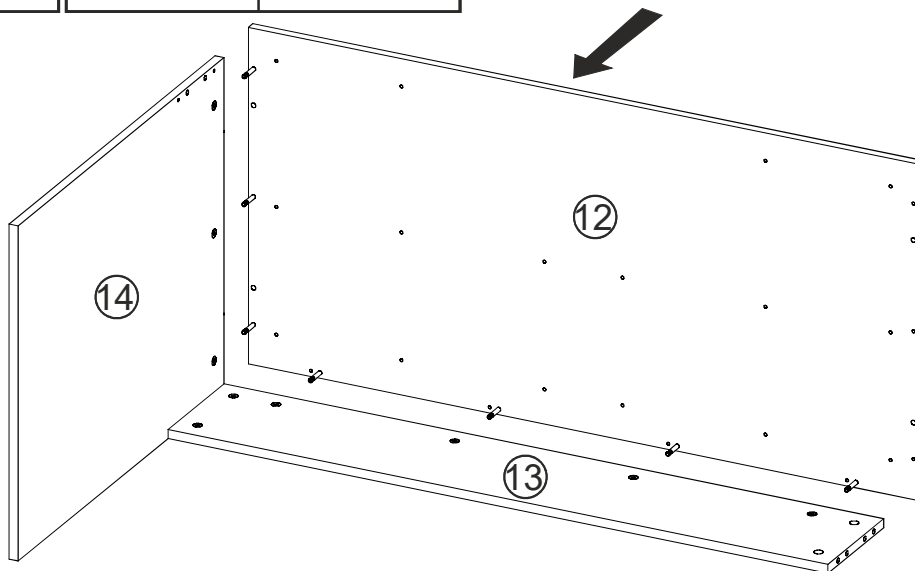
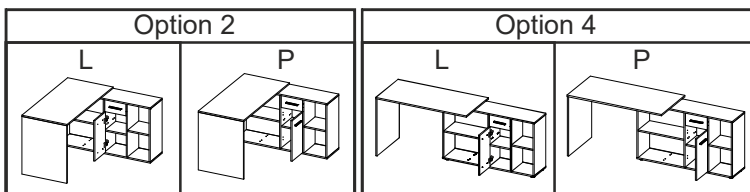
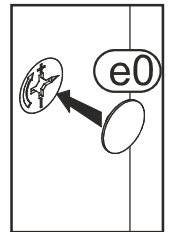
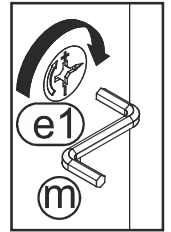
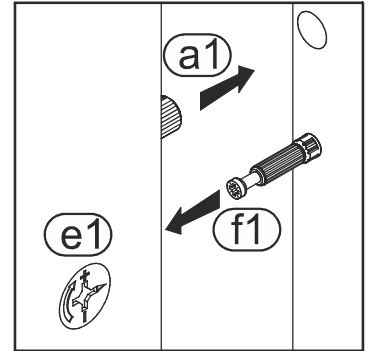
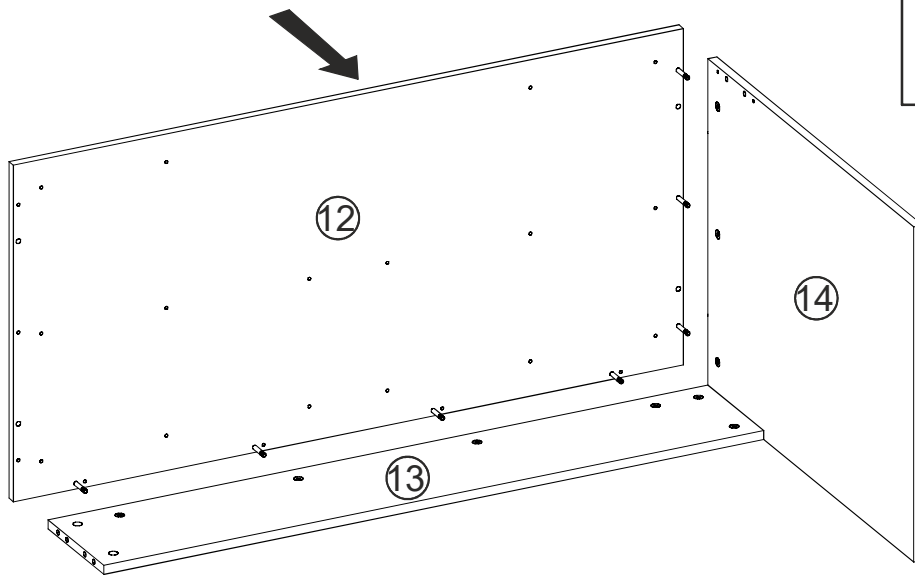
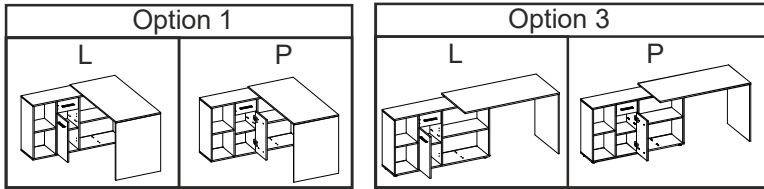

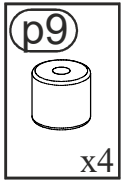
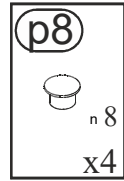
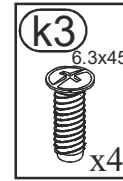
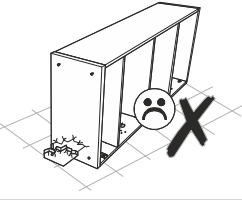
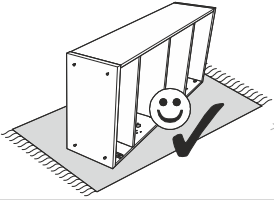

14

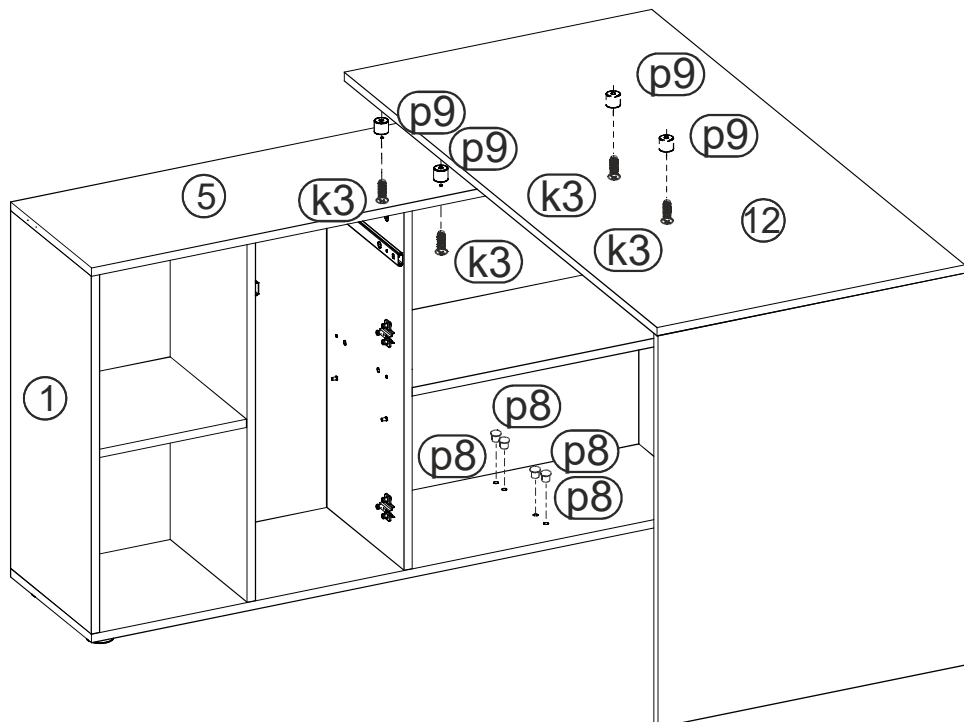
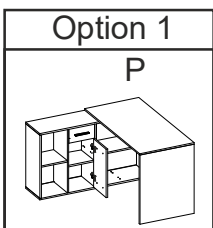
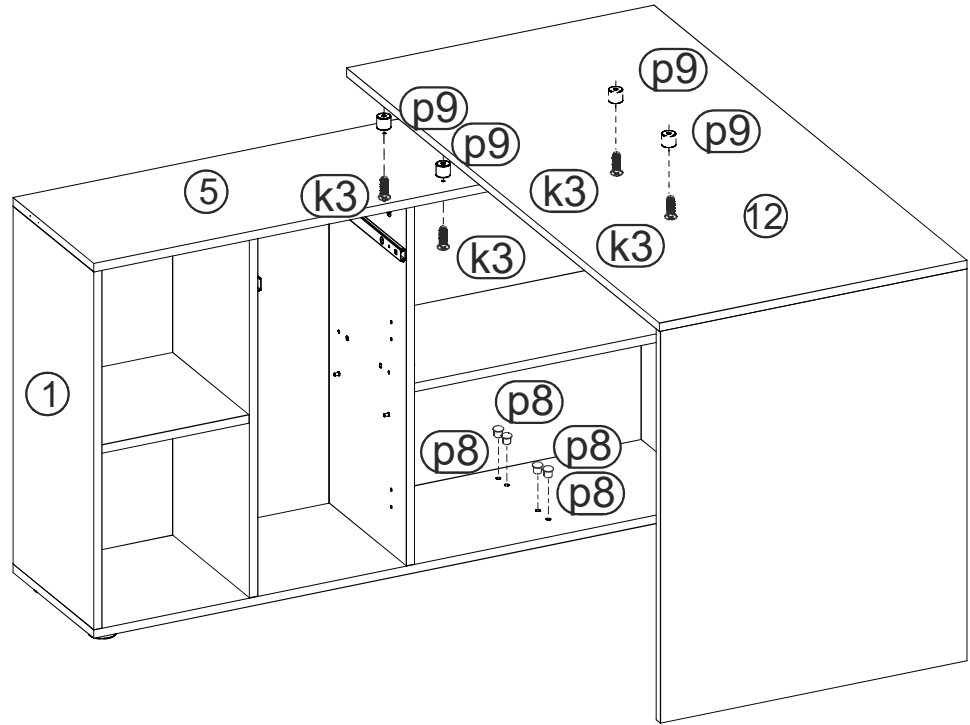
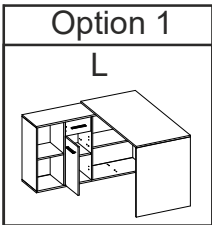

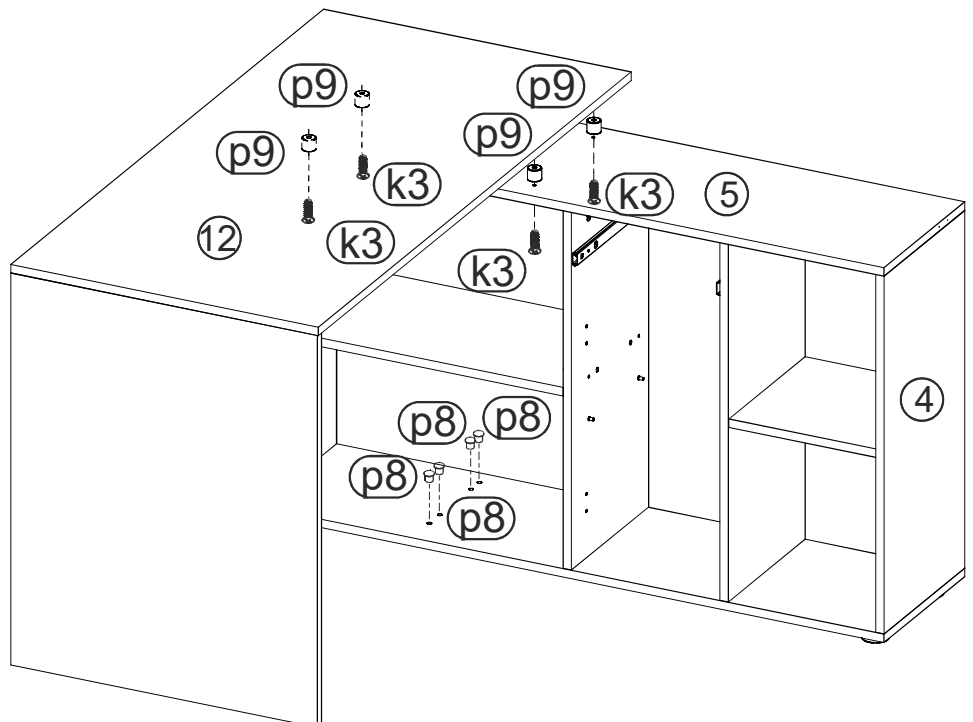
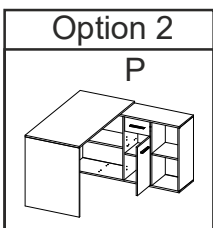
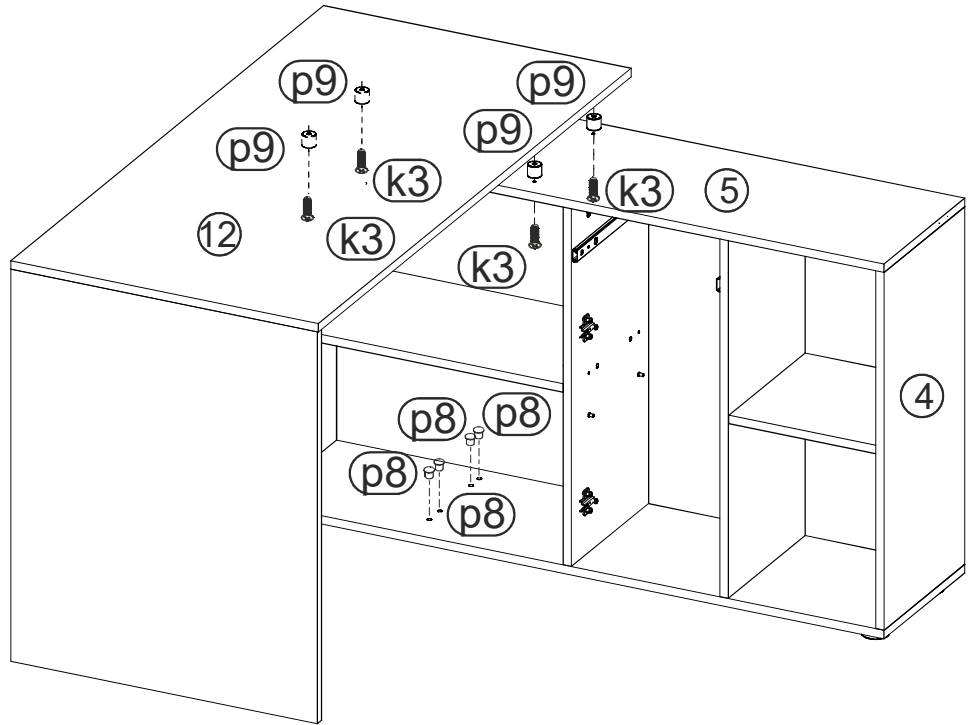
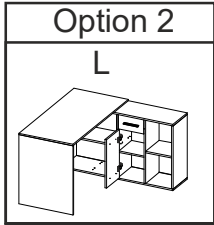
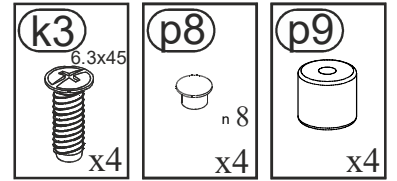
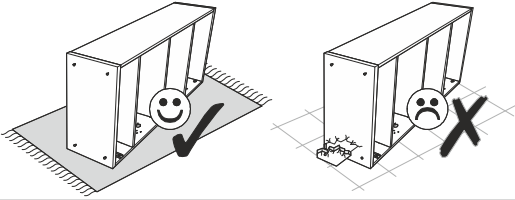

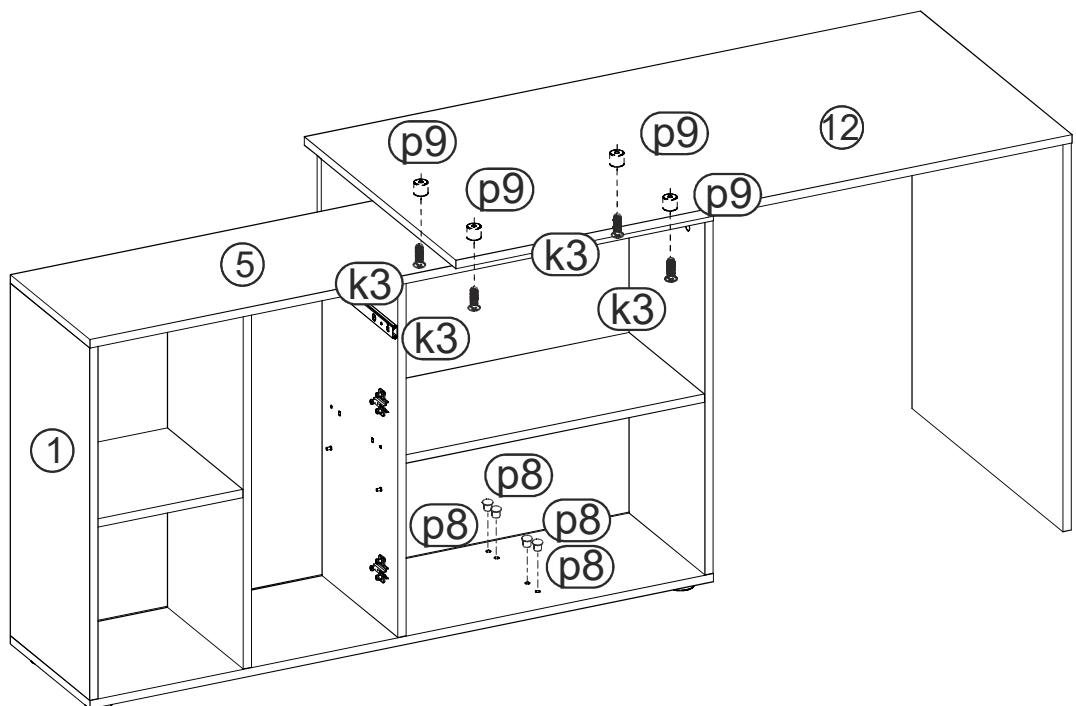
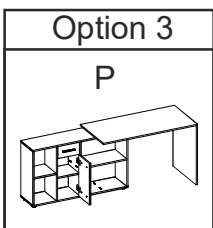
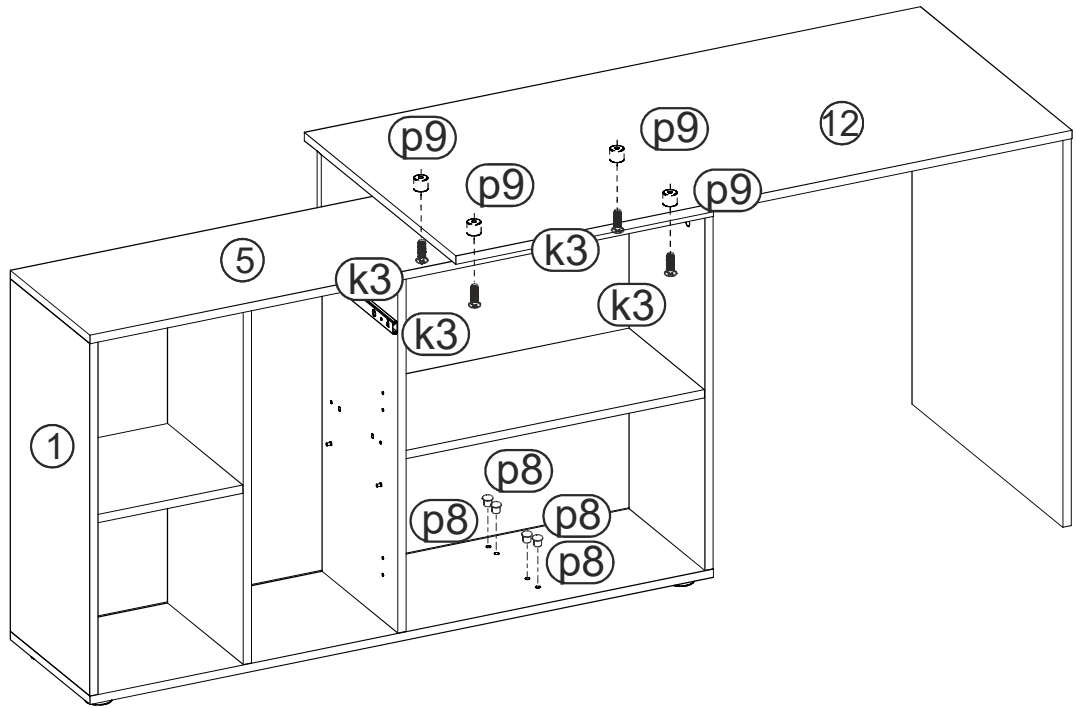
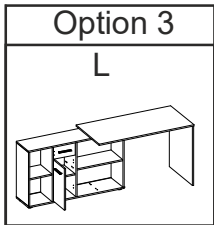
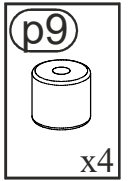
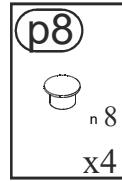
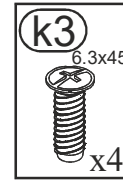
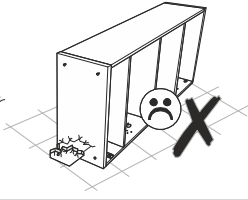
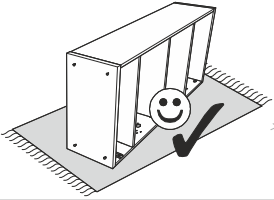

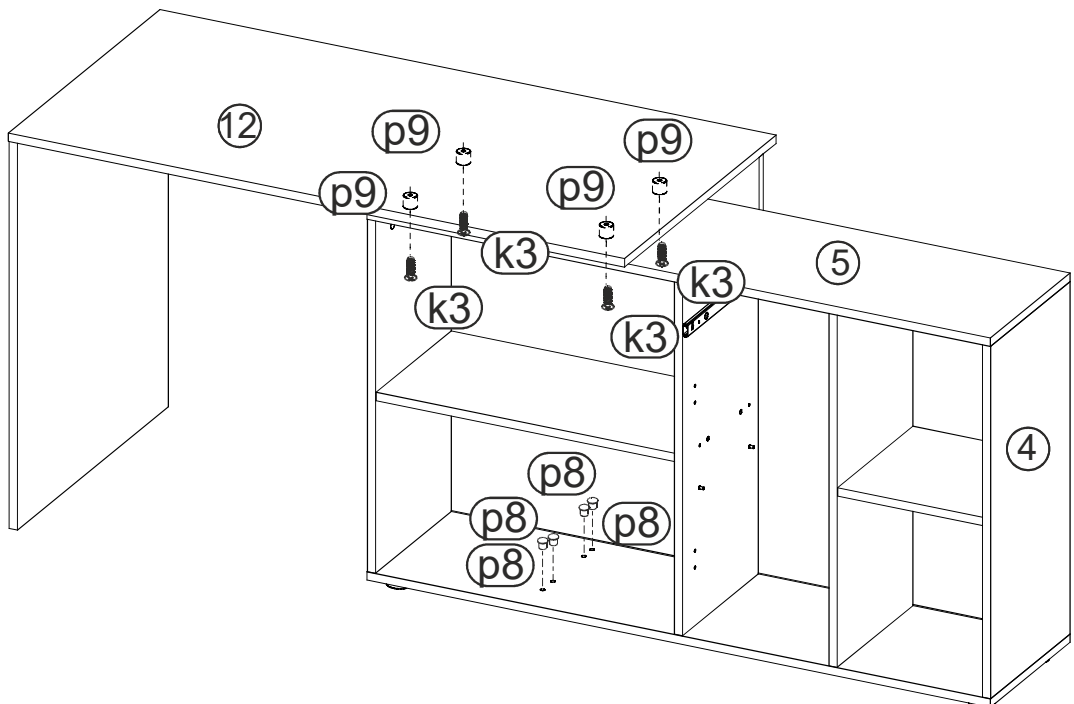
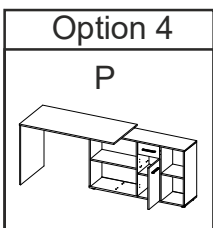
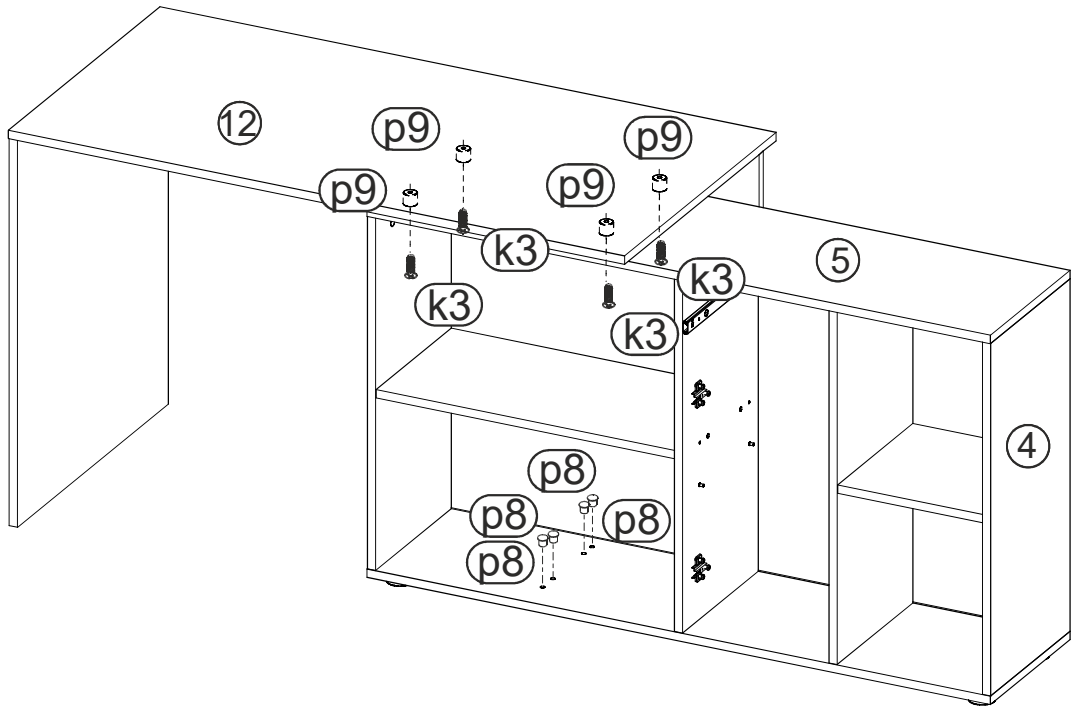
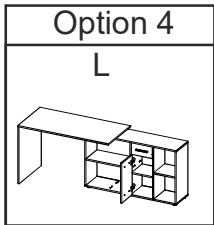
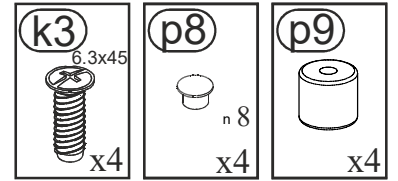
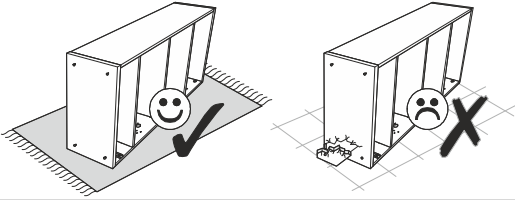

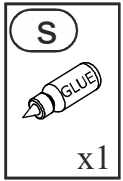
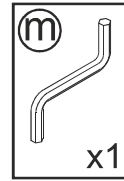
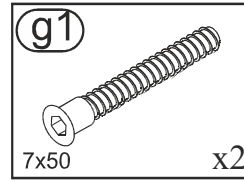
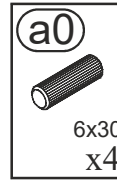
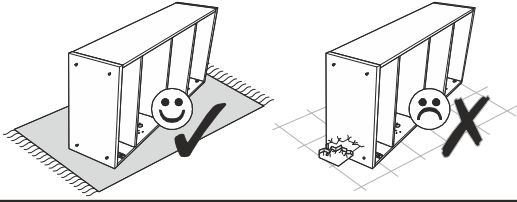

15

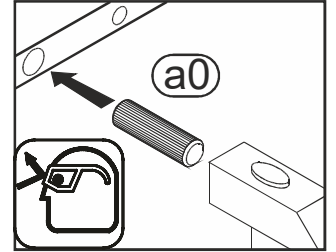
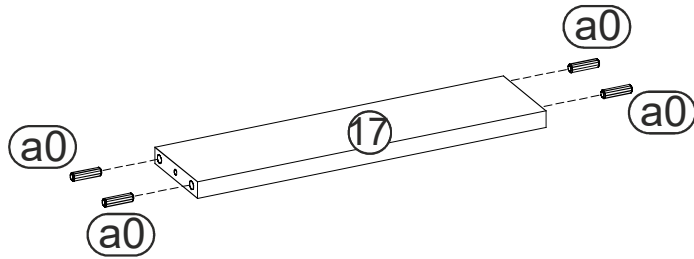

16

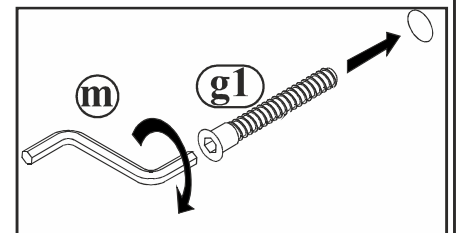
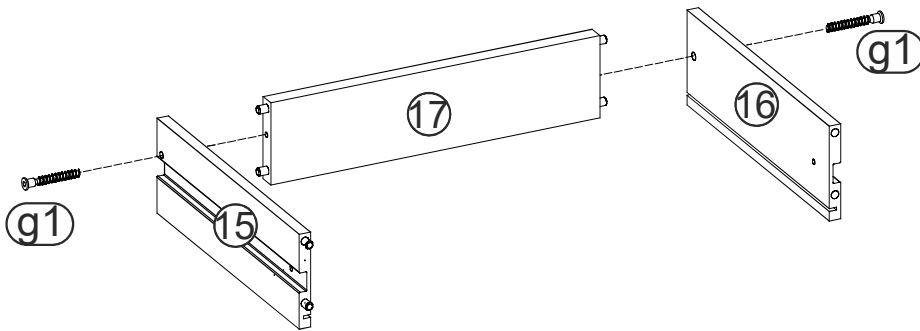

17

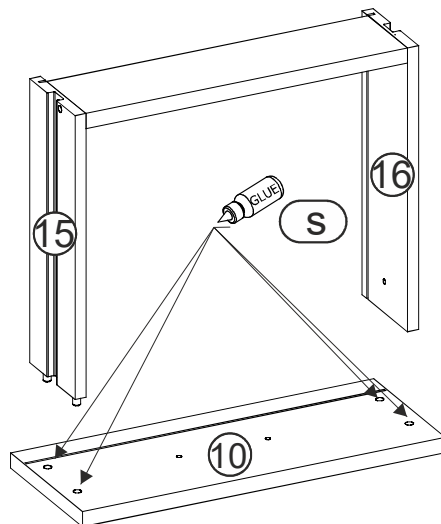

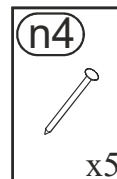
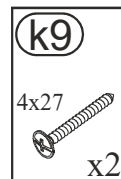
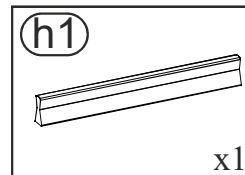
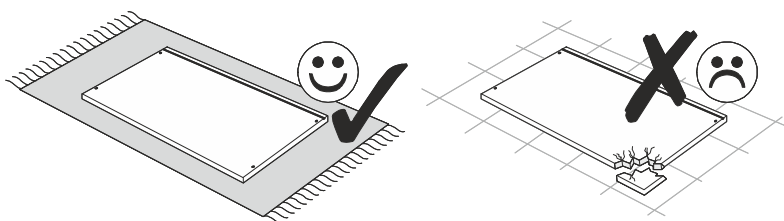

18

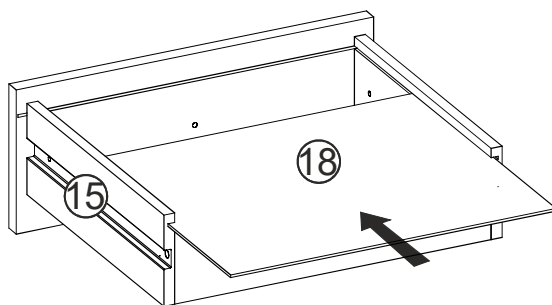

19

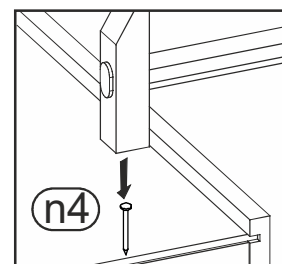
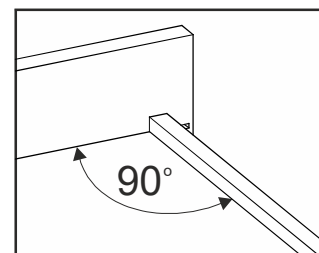
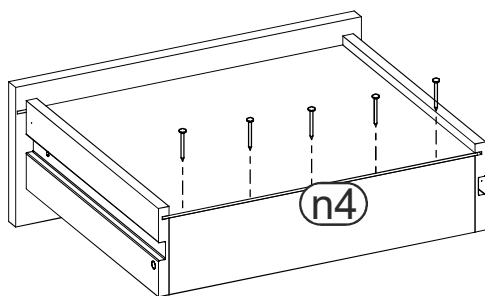

20

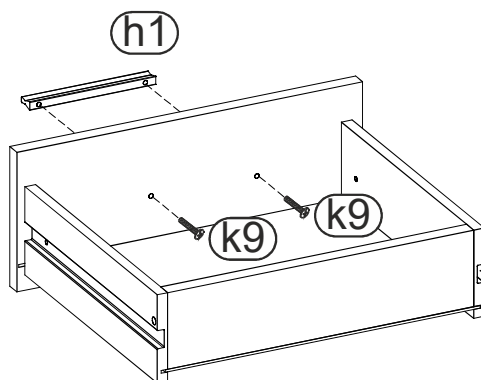

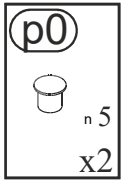
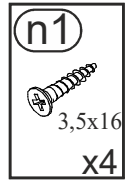
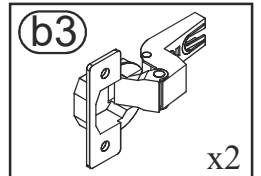
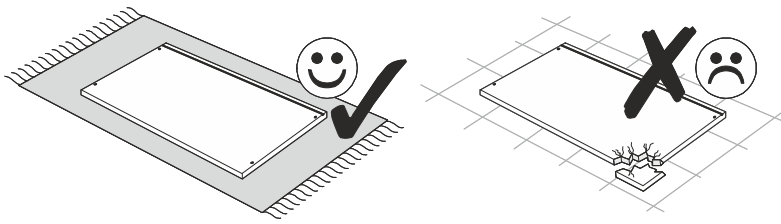

21

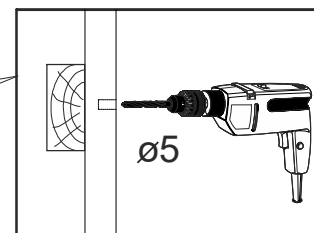
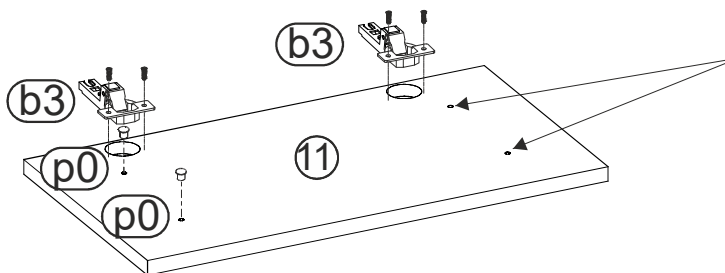
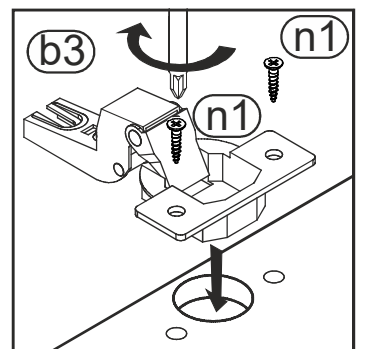
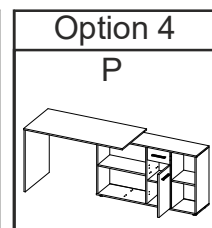
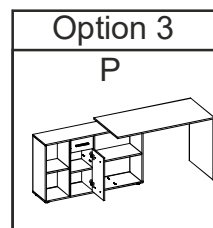
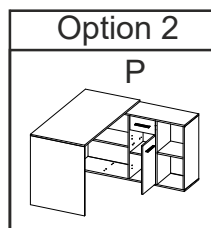
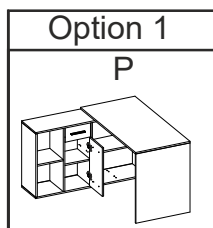
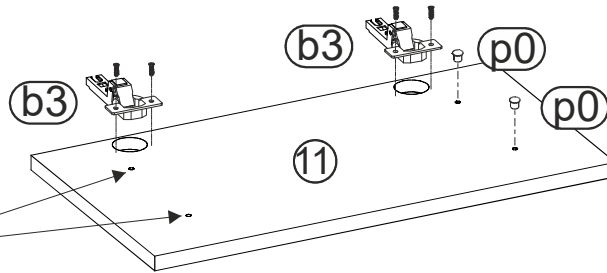
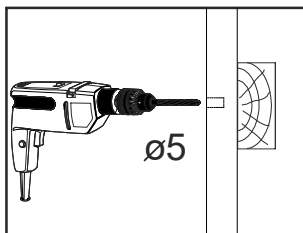
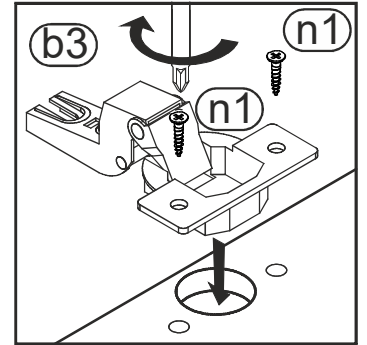
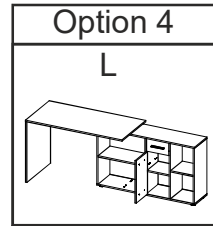
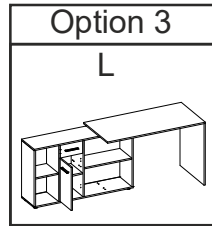
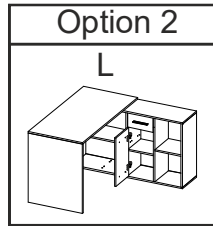
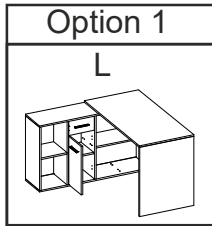

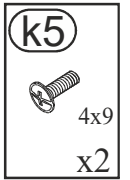
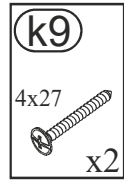
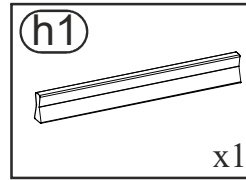
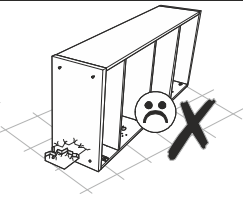
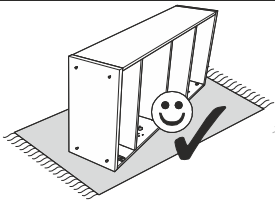

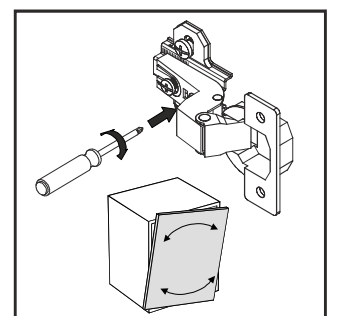
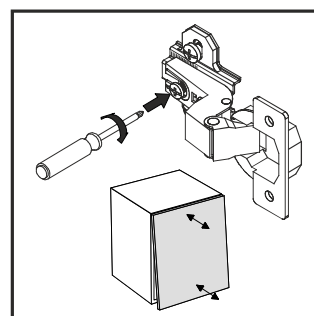
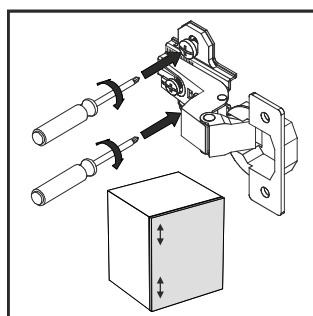
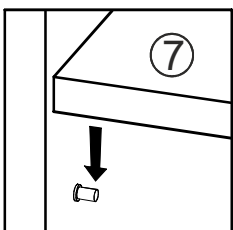
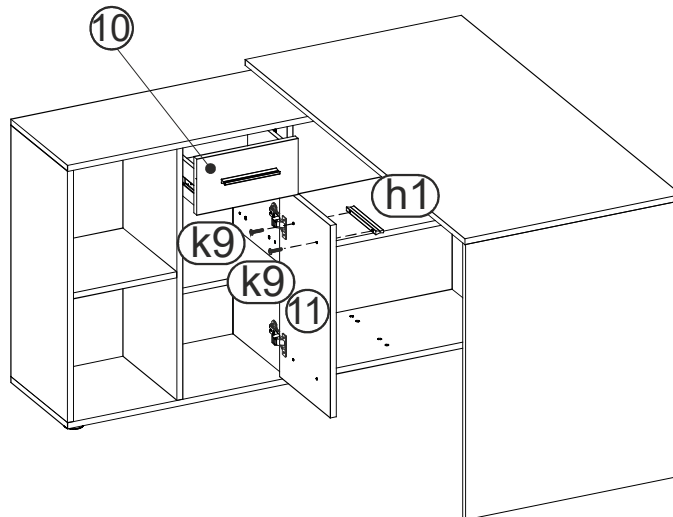
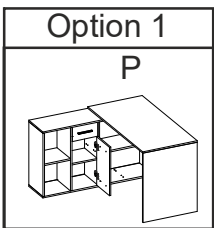
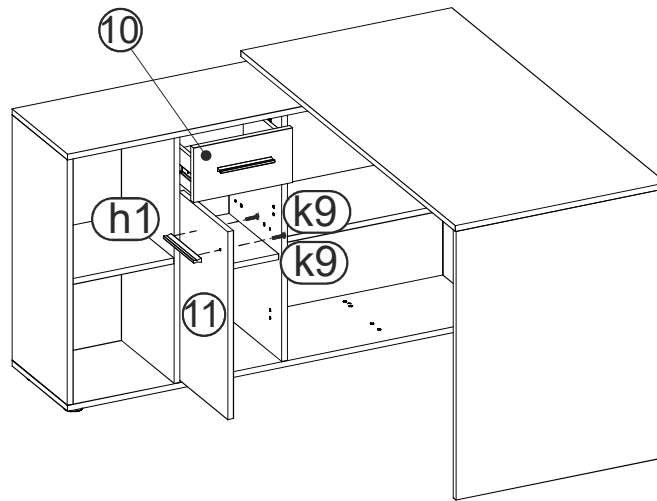
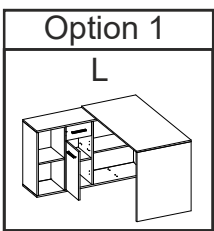
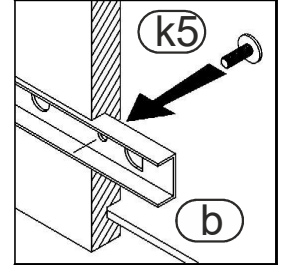
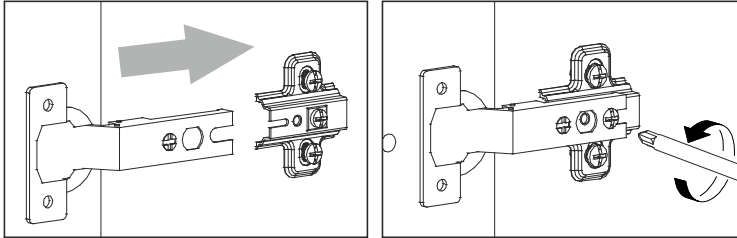

22

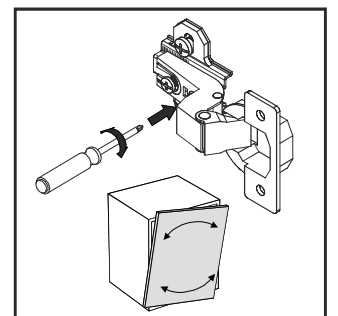
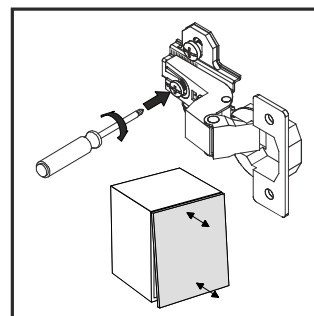
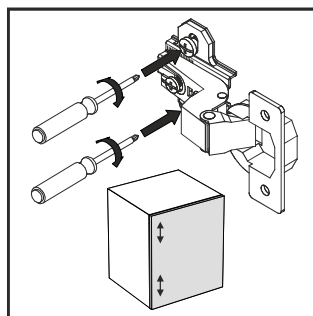
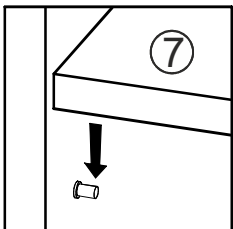
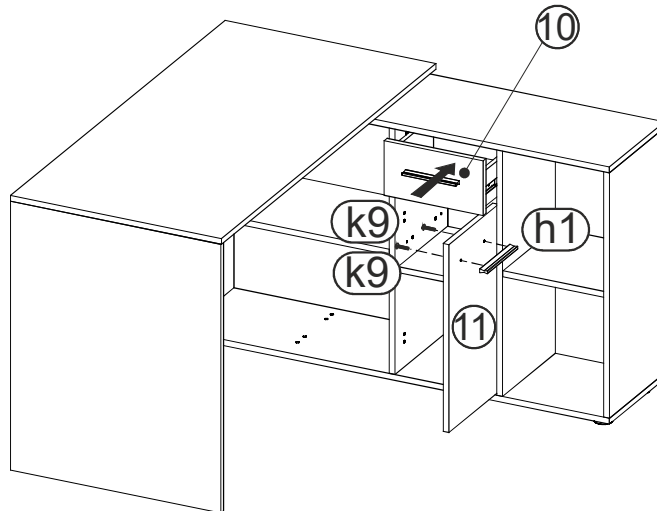
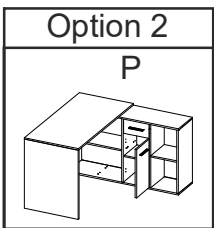
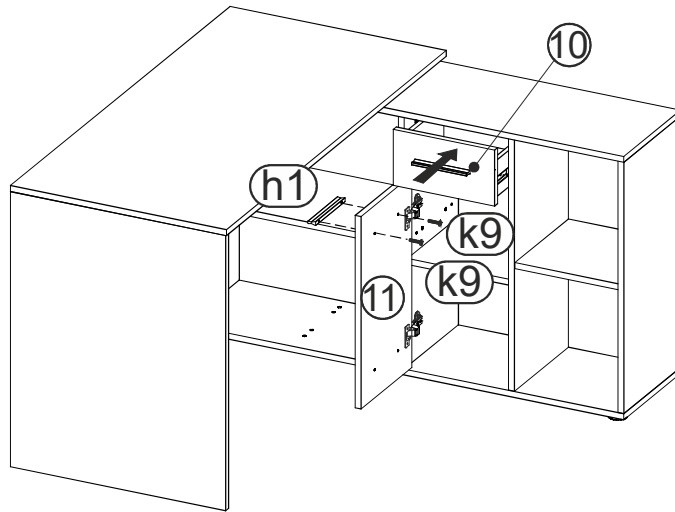
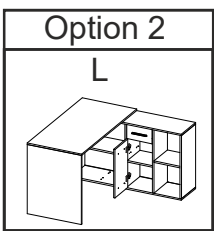
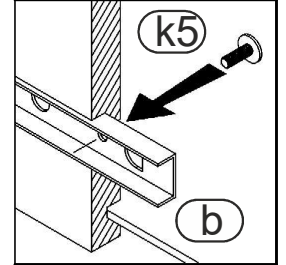
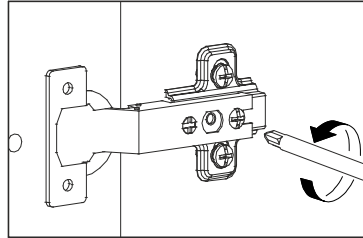
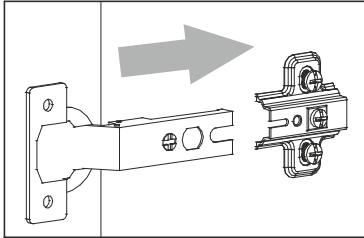
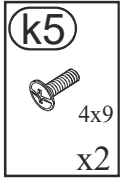
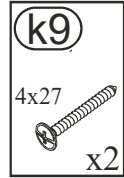
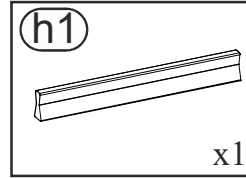
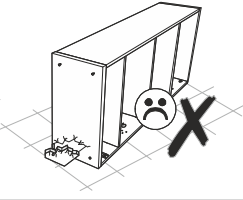
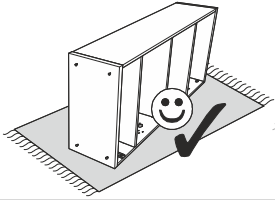

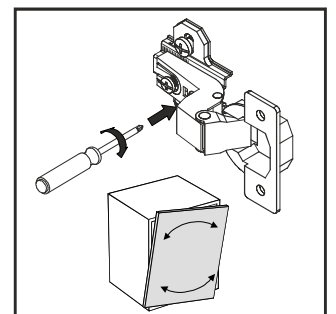
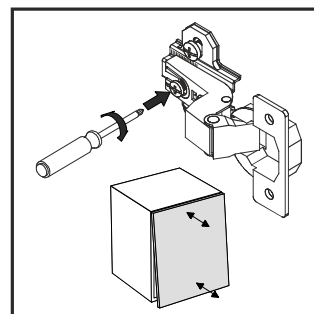
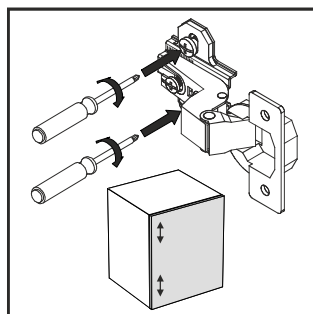
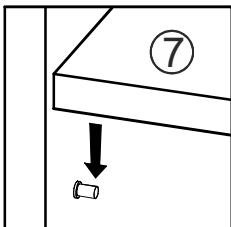
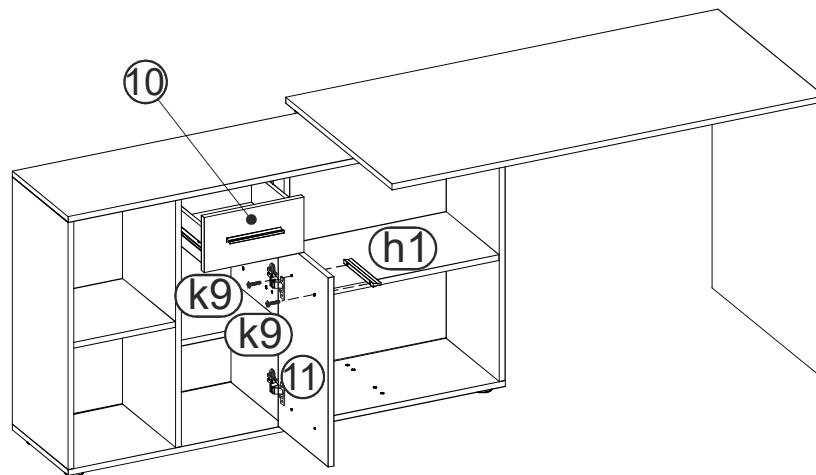
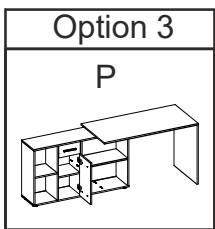
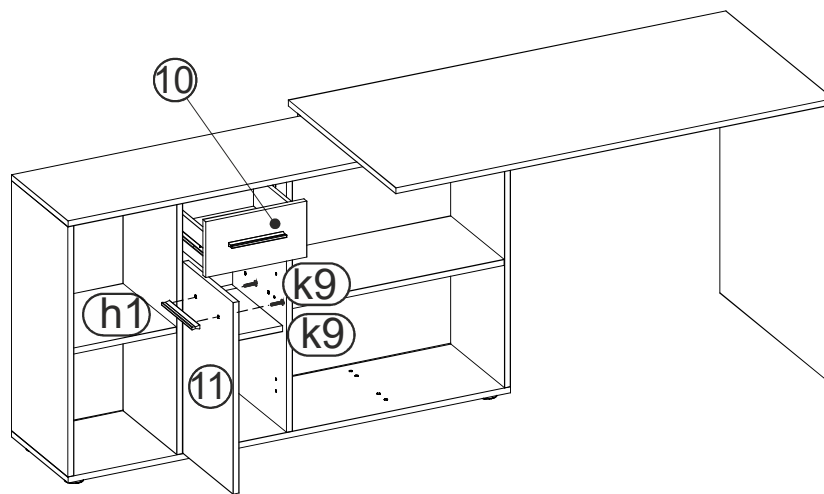
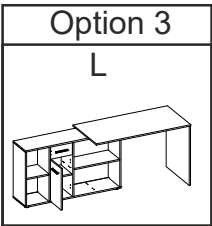
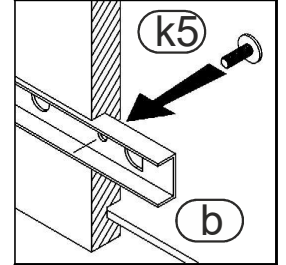
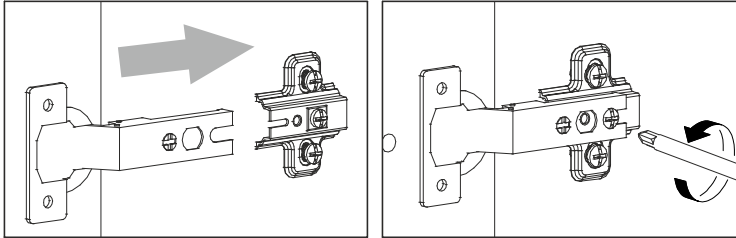
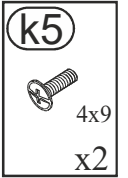
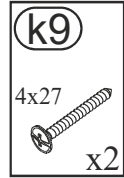
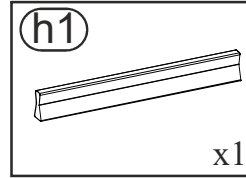
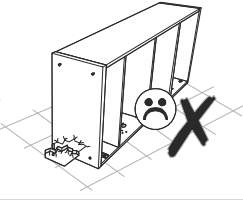
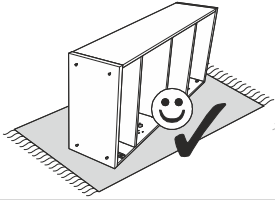

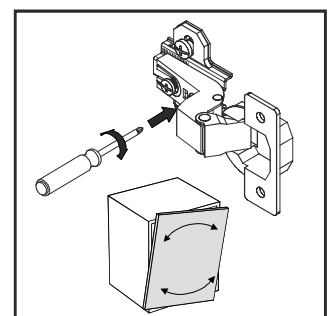
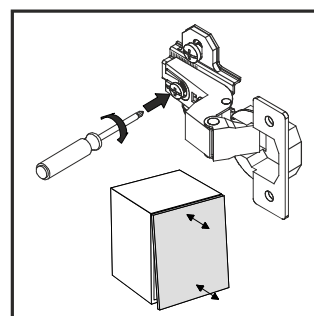
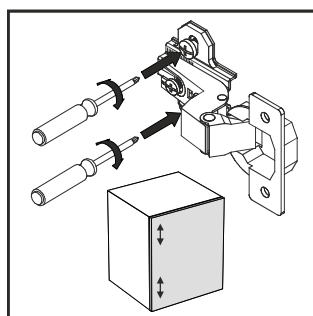
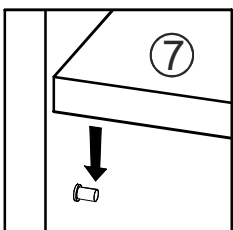
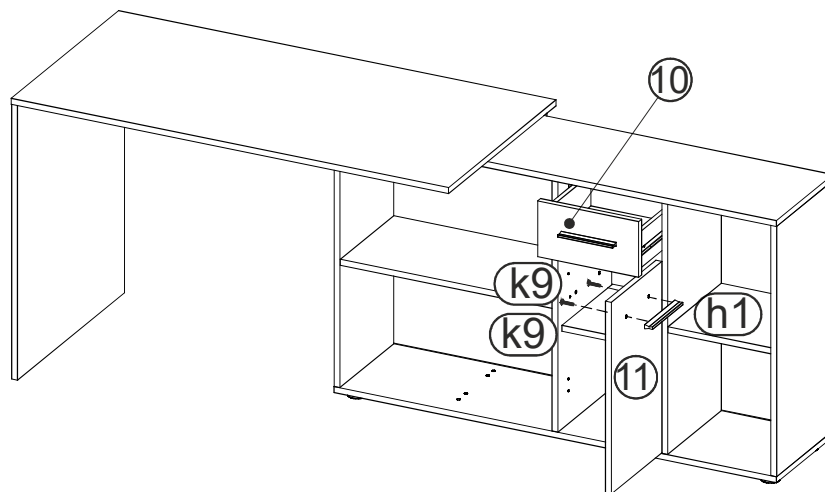
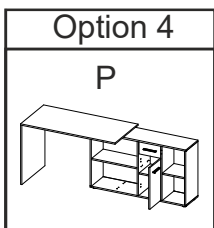
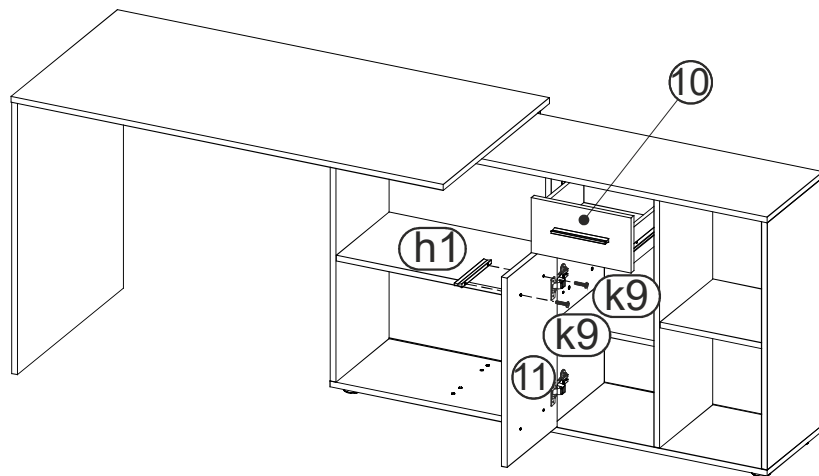
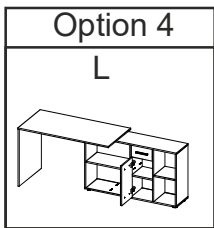
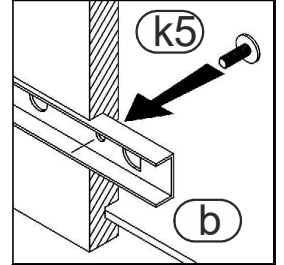
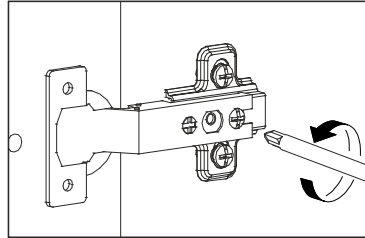
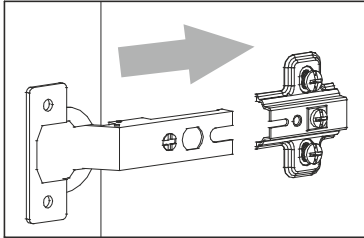
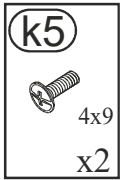
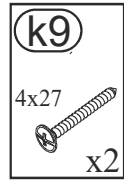
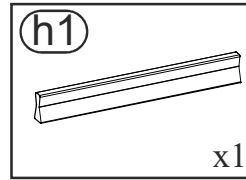
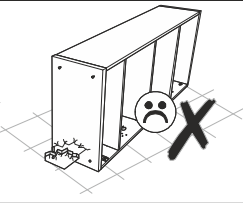
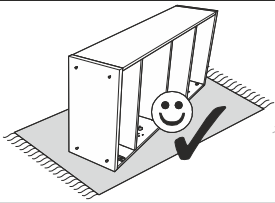



 Achtung • Opgelet • Uwaga • Dikkat • Внимание • Attention Upozornění • Figyelem • Attenzione • Atenție 	
D	Überschreiten Sie angegebenen Maximalbelastungen nicht. Andernfalls kann das Möbelstück beschädigt oder zerstört werden.
GB	Do not exceed the maximum loads specified. Otherwise, the furniture may sustain damage or be irreparably damaged.
NL	Overschrijd de aangegeven maximale belastingen niet. Anders kan het meubelstuk worden beschadigd of vernield.
PL	Nie wolno przekraczać podanych maksymalnych wartości obciążenia. W przeciwnym razie mebel może zostać uszkodzony lub zniszczony.
TR	Belirtilen azami yük değerini aşmayınız, aksi taktirde mobilya parçası zarar görebilir veya kullanılamaz hale gelebilir.
RU	Не допускается превышение указанных максимальных нагрузок. В противном случае возможно повреждение или разрушение мебели.
FR	Ne dépassez pas les charges maximum indiquées. Sinon, le meuble peut être endommagé ou détruit.
CZ	Nepřekračujte uvedená maximální zatížení. V opačném případě může dojít k poškození nebo zničení nábytku.
HU	Tartsa be az engedélyezett maximális terhelhetőséget/teljesítményt. Különben a bútor és annak alkatrészei megsérülhetnek, tönkre mehetnek.
IT	Non superare il carico massimo indicato. Altrimenti il mobile rischia di rovinarsi o frantumarsi.
RO	Nu depășiți solicitările maxime specificate. Altfel puteți să deteriorați sau să distrugeți piesa de mobilier.
SK	Neprekročte uvedené maximálne zaťaženia. V opačnom prípade sa môže nábytok poškodiť alebo zničiť.
Wall Mounting Instructions	
D	Die Befestigung des Möbelstückes an der Wand muss von einer fachkundigen Person vorgenommen werden, da für die Montage an die Wand angepasste Dübel erforderlich sind.
GB	A qualified professional is required when mounting furniture to the wall since dowels corresponding to the wall are required for this.
NL	Een vakkundige persoon dient het meubelstuk aan de muur te bevestigen; voor de montage aan de muur zijn immers aangepaste pluggen vereist.
PL	Mocowanie mebla do ściany mogą przeprowadzić wyłącznie wykwalifikowane osoby, z uwagi na zastosowanie odpowiednio dopasowanych kołków do rodzaju ściany.
TR	Mobilya parçasının duvara sabitlenmesi, duvar montajı için özel uyarlanmış dübeller gerektirdiğinden bu iş sadece bu konuda uzman bir kişi tarafından gerçekleştirilmelidir.
RU	Поскольку для монтажа на стене необходимо использовать специальные дюбели, мебель должна быть закреплена на стене квалифицированным персоналом.
FR	La fixation du meuble contre le mur doit être effectuée par une personne compétente car, pour le montage mural, il faut utiliser des chevilles adaptées.
CZ	Montáž nábytku na stěnu musí provést odborník, protože k montáži na stěnu jsou zapotřebí upravené hmoždinky.
HU	A bútorelemek falra rögzítését szakembernek kell végeznie, mert a rögzítéshez megfelelő tiplit kell használni.
IT	Il fissaggio del mobile alla parete deve essere eseguito da persone esperte, dato che occorrono tasselli adeguati.
RO	Fixarea la perete a piesei de mobilier se realizează numai de către personal competent, deoarece montajul de perete necesită dibluri adecvate.
SK	Upevnenie nábytku na stenu musí vykonať odborník, nakoľko sú pre montáž na stenu potrebné vhodné hmoždinky.