

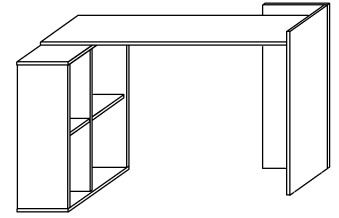

HEROS

→ 122 ↑ 81 ↘ 72



x 8



x 15



x 11



(a)

(b)

(c)

x 11



x 9



x 4

(3,5x30)



x 1

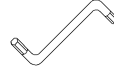

(d)

(e)

(f)

(h)

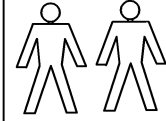

50 min



1

x 3



x 6



(b)

(c)

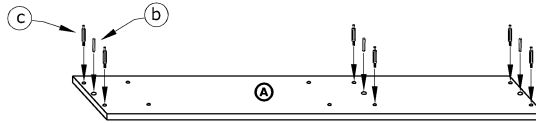

2

x 8



(b)

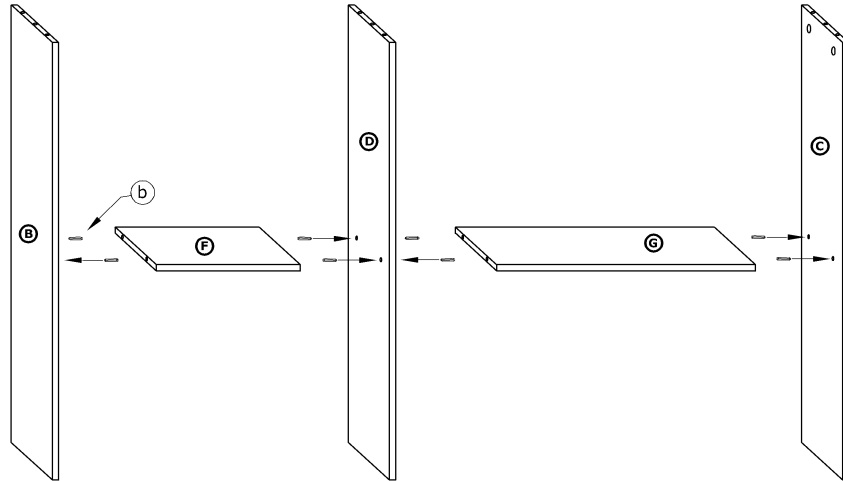

3

x 6



(a)

x 6



(d)

x 5



(e)

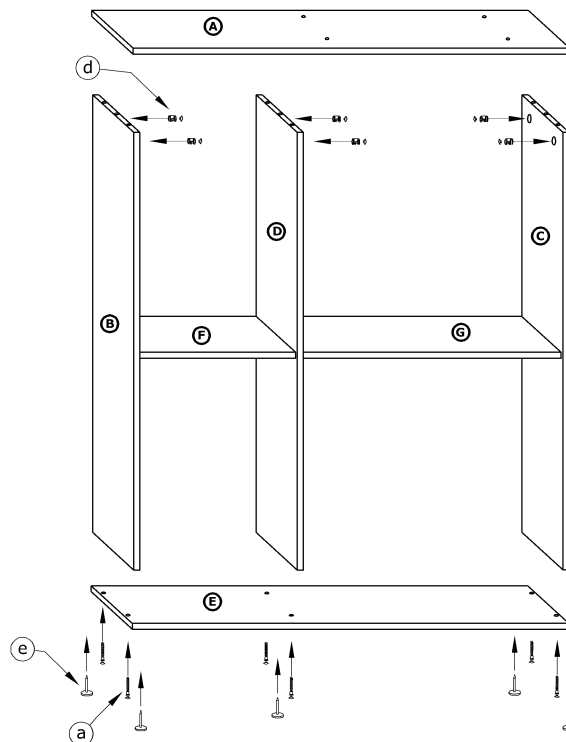

4

x 3



(b)

x 5



(c)

x 4

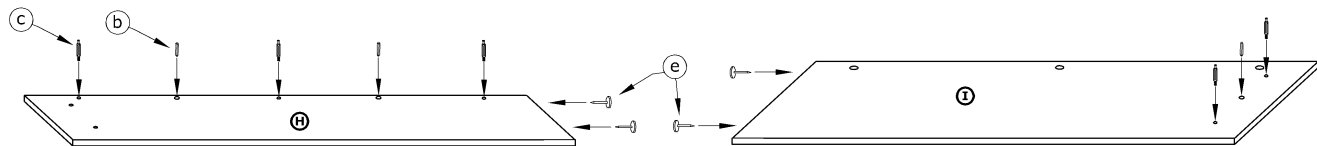

(e)

**5**

x 5

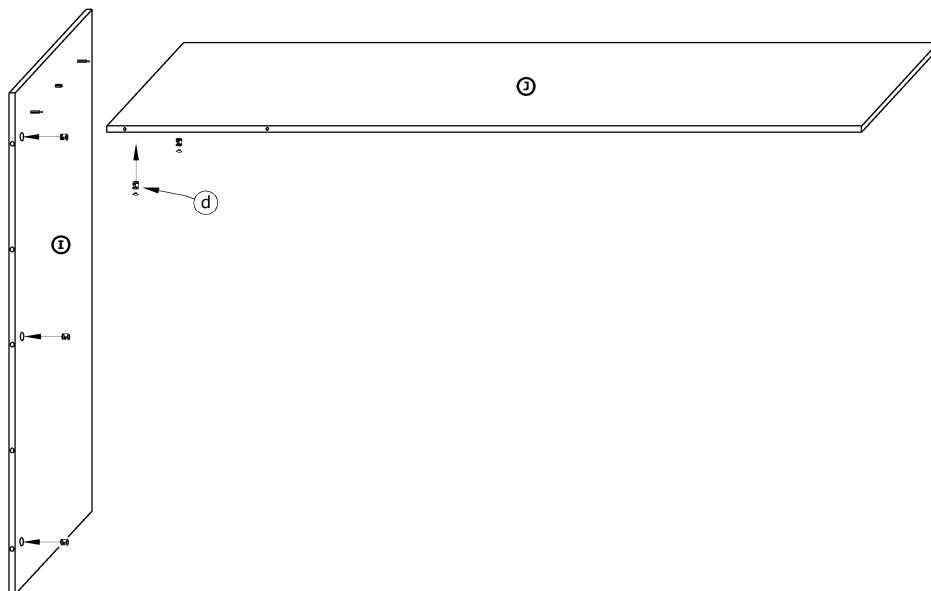

(d)

**6**

x 2



(a)

x 4

(3,5x30)



(f)

