

ELÉMENT BAS DE SALLE DE BAINS

N° 783911/12

GB - fitted basin unit

D - Waschbeckeneinbaumöbel

E - mueble de encastrar para pila

P - móvel para pia embutida

I - mobile da incastro per vasca

NL - inbouwkastje voor fonteintje



AVERTISSEMENT. Cette notice est destinée à repérer les pièces et à faciliter le montage du meuble et ne peut en aucun cas être contractuelle, en effet les caractéristiques des produits sont susceptibles d'être modifiées sans préavis par le fabricant afin d'en améliorer la qualité.

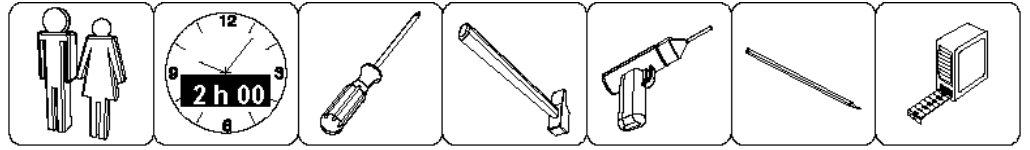

GB - IMPORTANT. These instructions are to be used to identify the parts and facilitate furniture assembly and are in no case binding. Product characteristics are subject to change without notice from the manufacturer to improve quality.

D - HINWEIS. Diese Anleitung dient nur zum Erkennen der Teile und zur Erleichterung der Montage des Möbels und ist keinesfalls verbindlich, da die Merkmale des Produkts ohne Vorbescheid des Herstellers geändert werden können, um ihre Qualität zu verbessern.

E - ADVERTENCIA: este folleto explicativo está destinado a identificar las piezas y facilitar el montaje del mueble, en ningún caso podrá ser considerado como un contrato. El fabricante puede modificar las características del producto sin previo aviso para mejorar su calidad.

P - AVISO: Este folheto destina-se a identificar as peças e a facilitar a montagem do móvel e não pode, de modo algum, ser contratual. De facto, as características do produto podem ser modificadas sem aviso prévio pelo fabricante para a melhorar a sua qualidade.

I - AVVERTENZA - Queste istruzioni sono destinate a distinguere i pezzi e a facilitare il montaggio del mobile e non sono in nessun caso contrattuali; le caratteristiche del prodotto sono infatti soggette a modifiche senza preavviso da parte del costruttore al fine di migliorarne la qualità.

NL - WAARSCHUWING. Deze handleiding is bedoeld om de verschillende onderdelen te herkennen en het monteren van de meubels te vergemakkelijken en is in geen geval bindend, daar zonder voorafgaand bericht van de fabrikant de eigenschappen van het product gewijzigd kunnen worden, teneinde de kwaliteit hiervan te verbeteren.

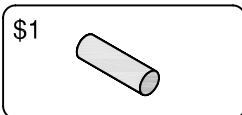
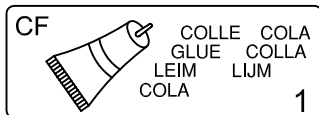
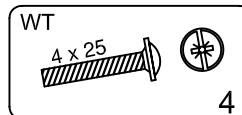
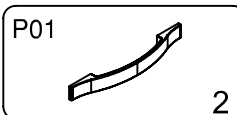
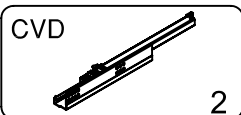
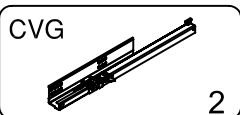
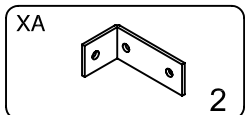
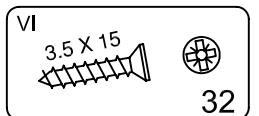
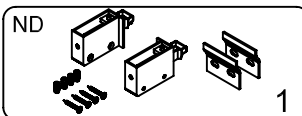
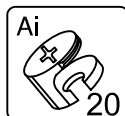
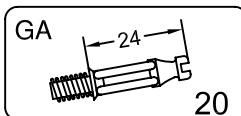
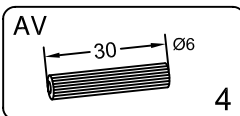
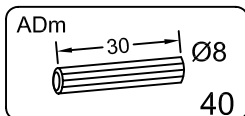
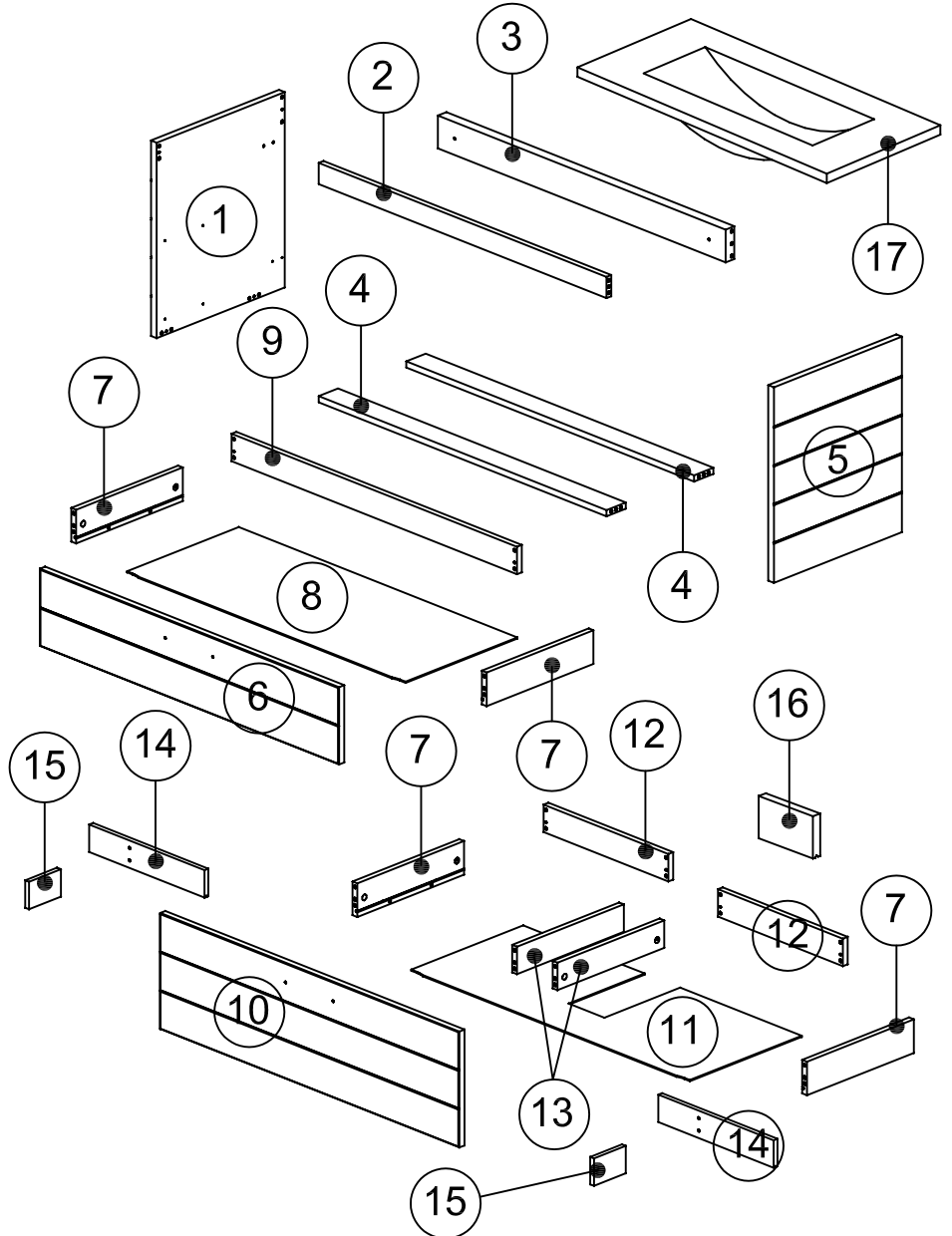
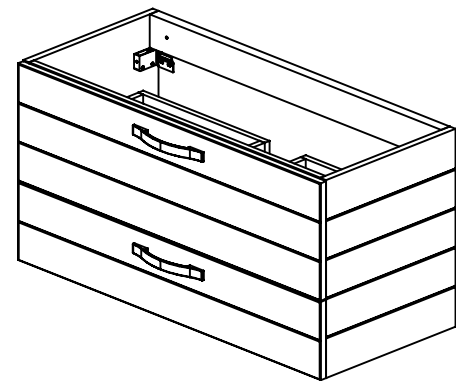

COLLE COLA
GLUE COLLA
LEIM LIJM
COLA

1

- GA 24 4
- CVG 2
- XA 1
- ND 1
- VI 3.5 X 15 6

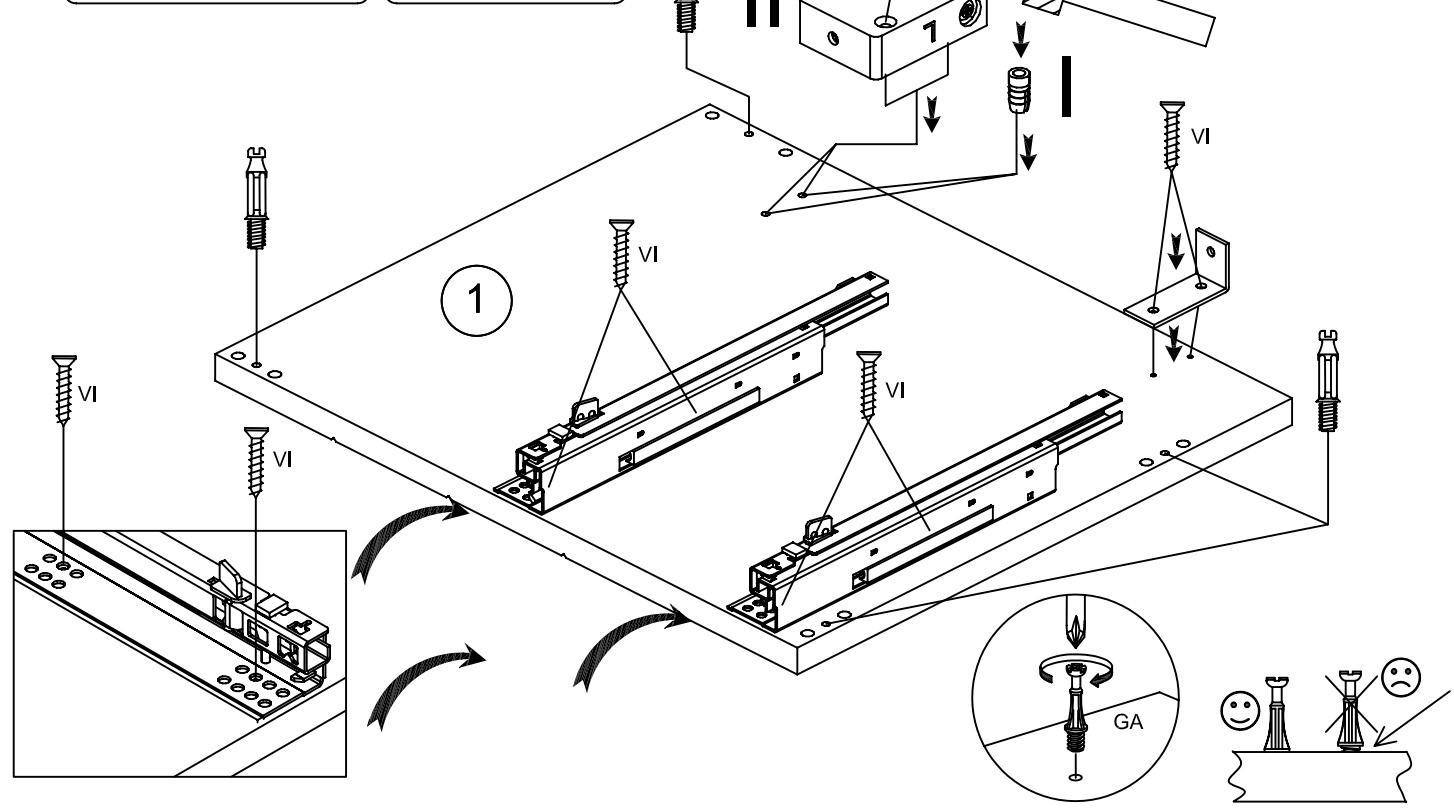

2

- GA 24 4
- CVD 2
- VI 3.5 X 15 6
- XA 1
- ND 1

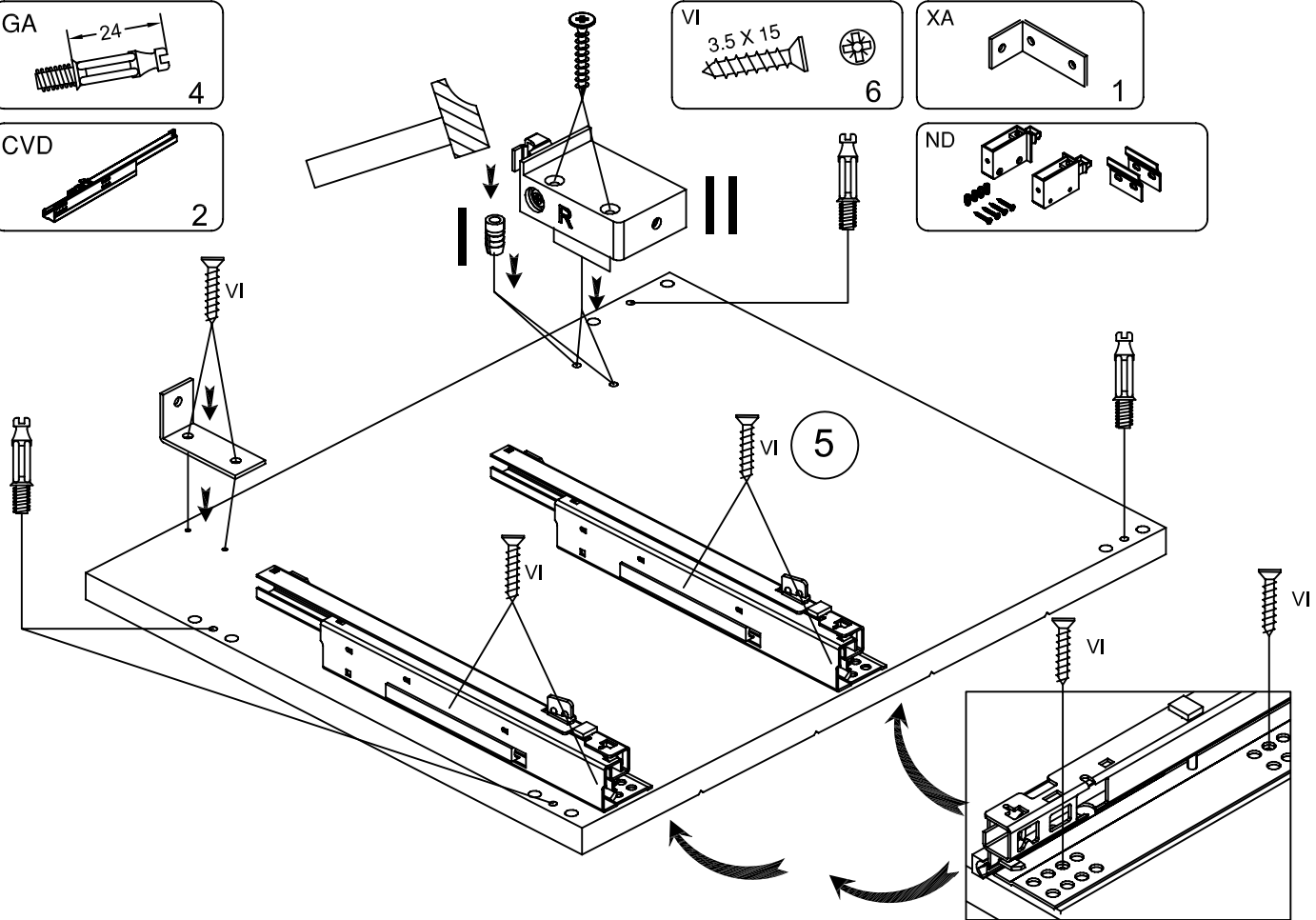

783911/12.2

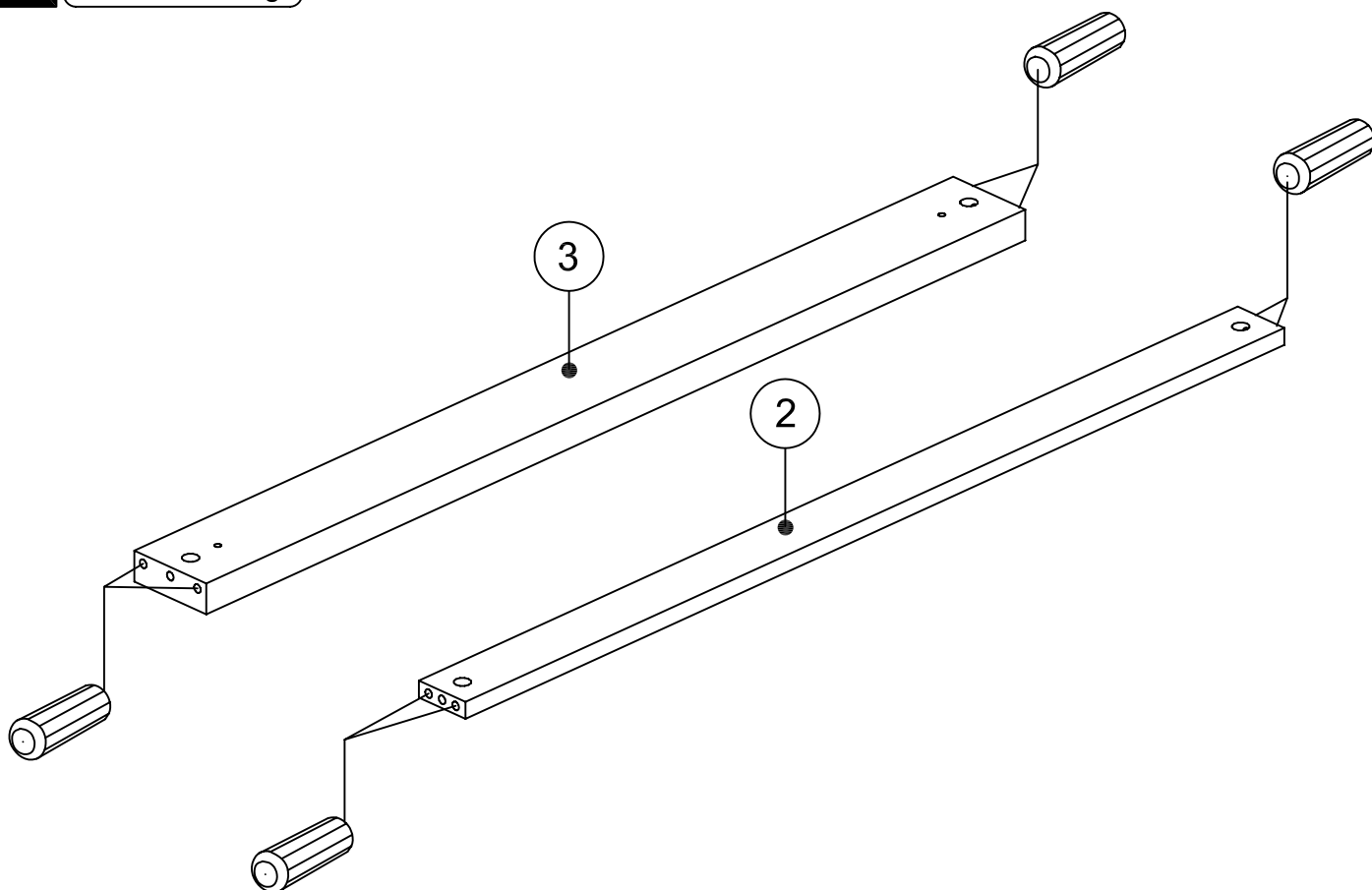
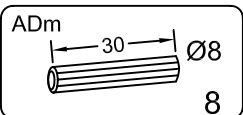
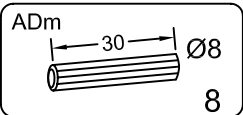
3**4****2 PIECES**

- Ⓒ 2 PARTS
- Ⓓ 2 STÜCKEN
- Ⓔ 2 PIEZAS
- Ⓕ 2 PECAS
- Ⓖ 2 PEZZI
- Ⓝ 2 STUKS

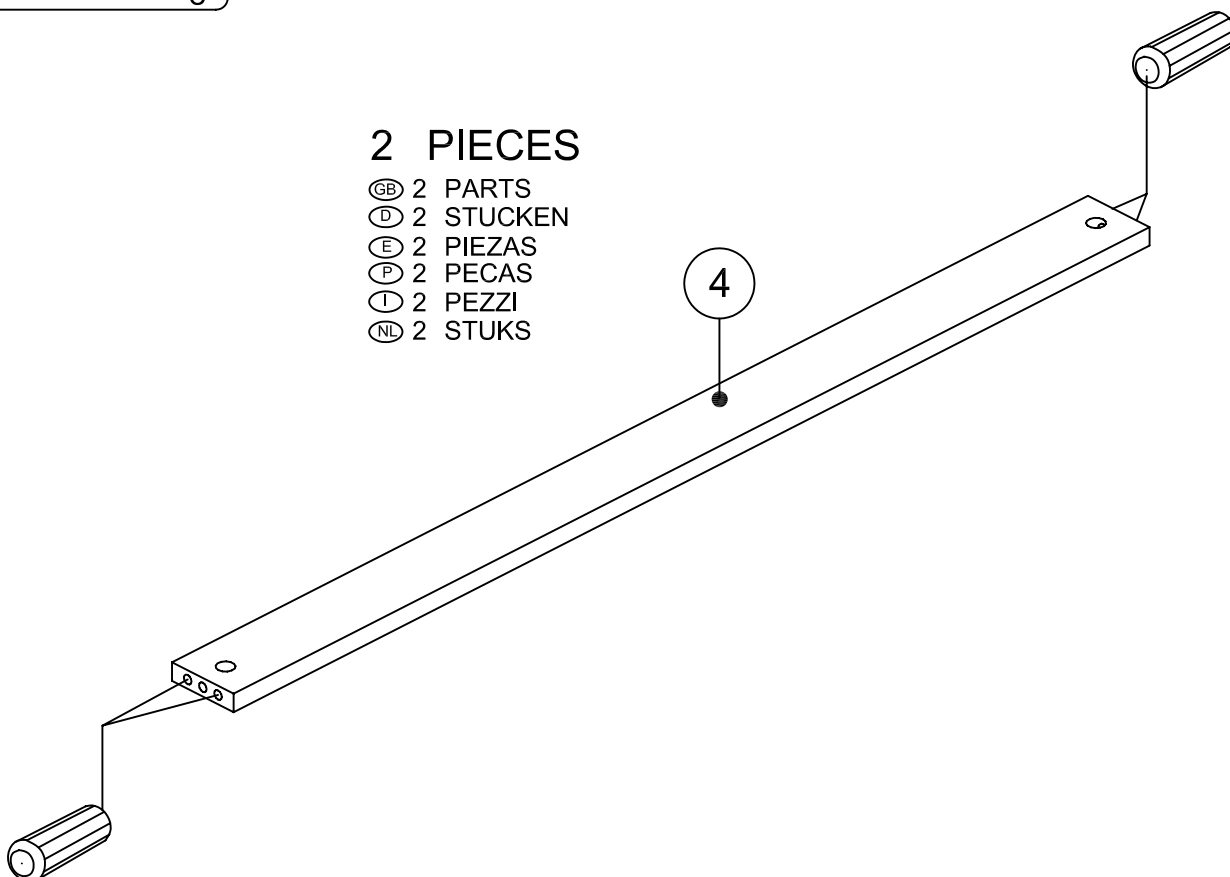

783911/12.3

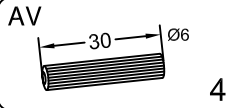
5

COLLE COLA
GLUE COLLA
LEIM LIJM
COLA

1

REMUER AVANT EMPLOI

2 PIECES

- Ⓒ 2 PARTS
- Ⓓ 2 STUCKEN
- Ⓔ 2 PIEZAS
- Ⓕ 2 PECAS
- Ⓖ 2 PEZZI
- Ⓗ 2 STUKS

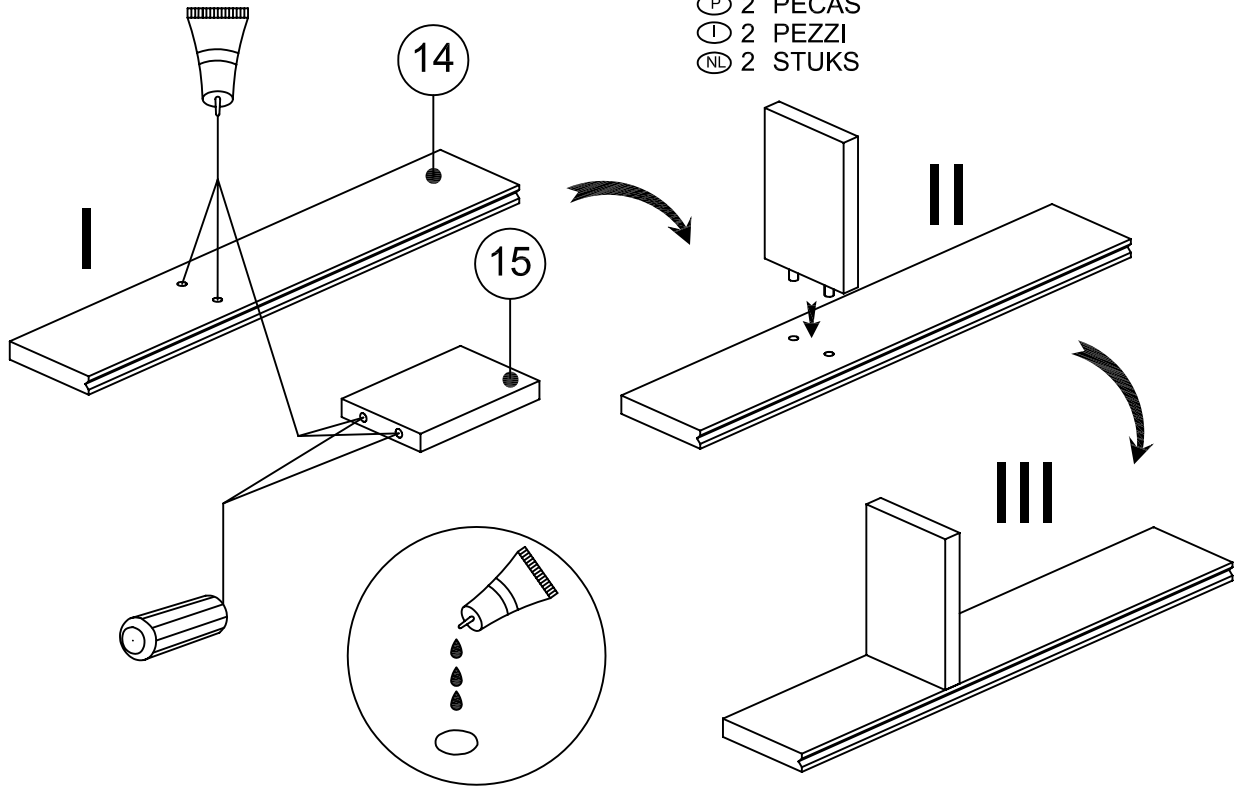
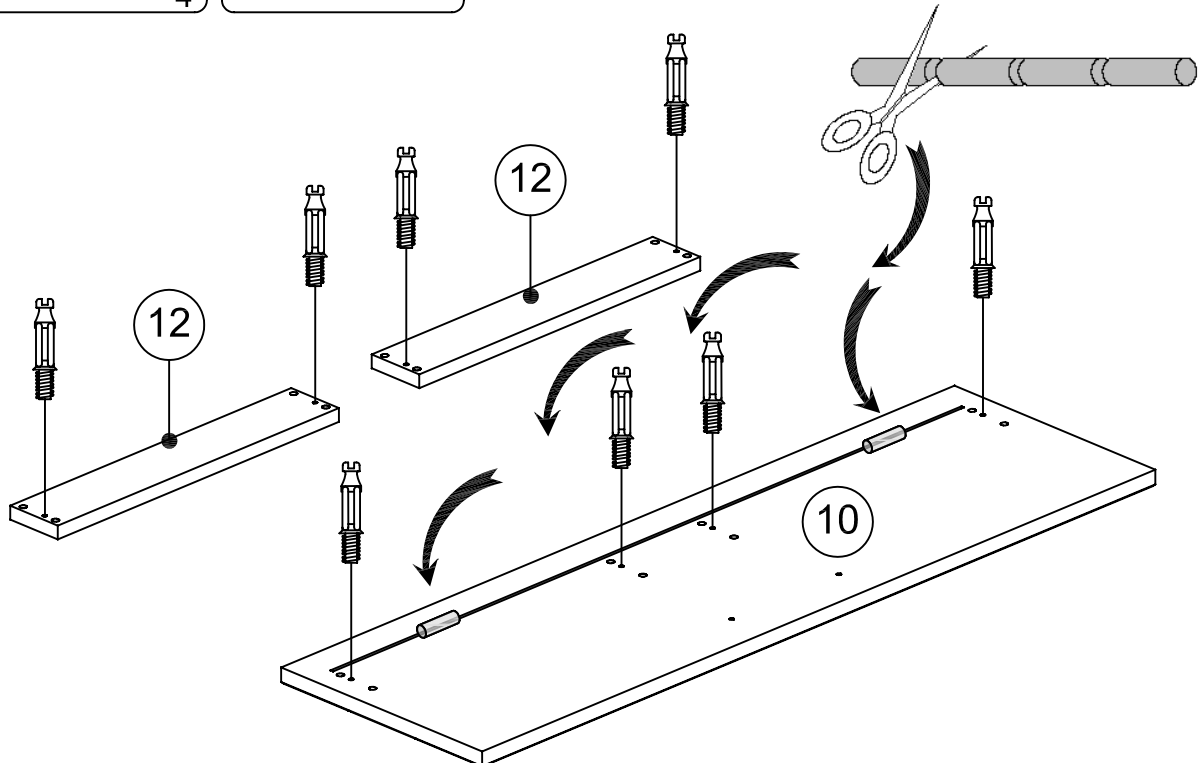
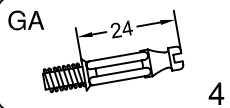
**6**

783911/12.4

7

GA

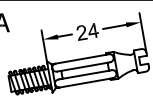

4

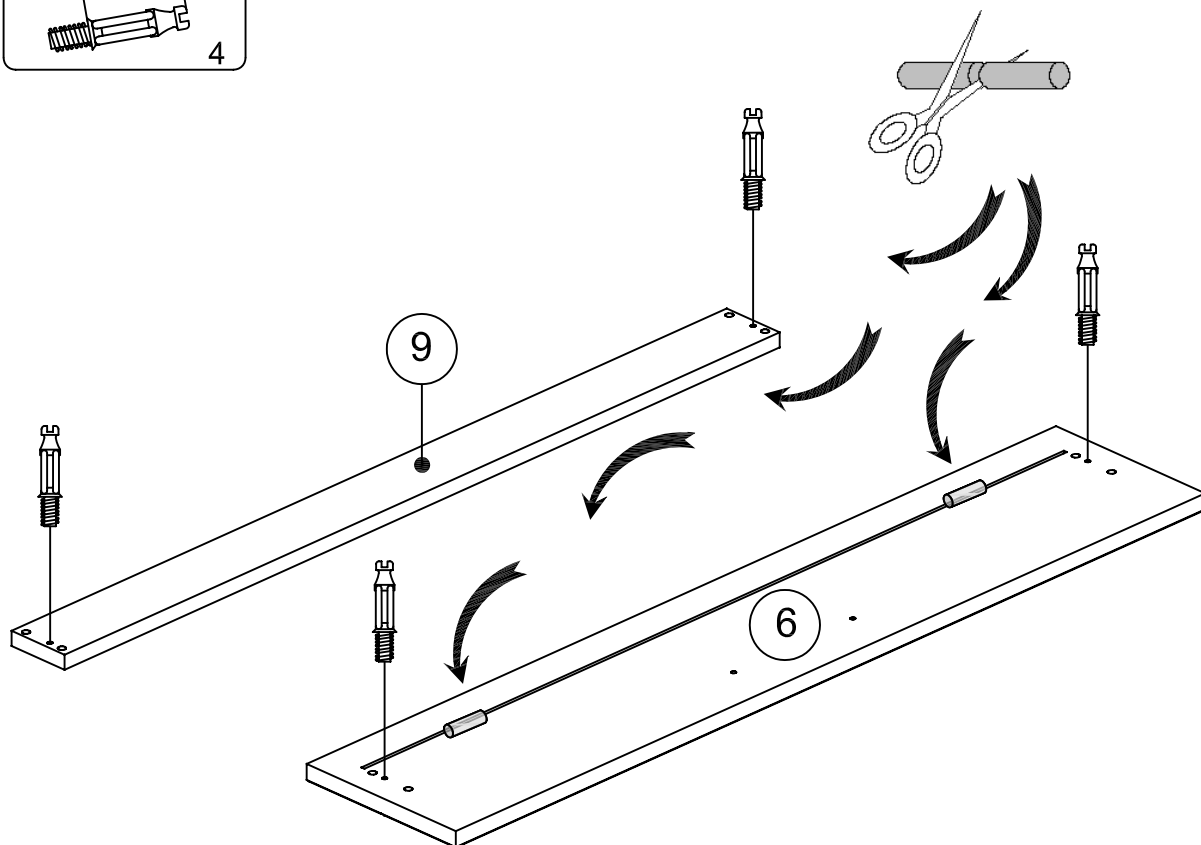

8

ADm

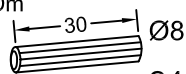

24

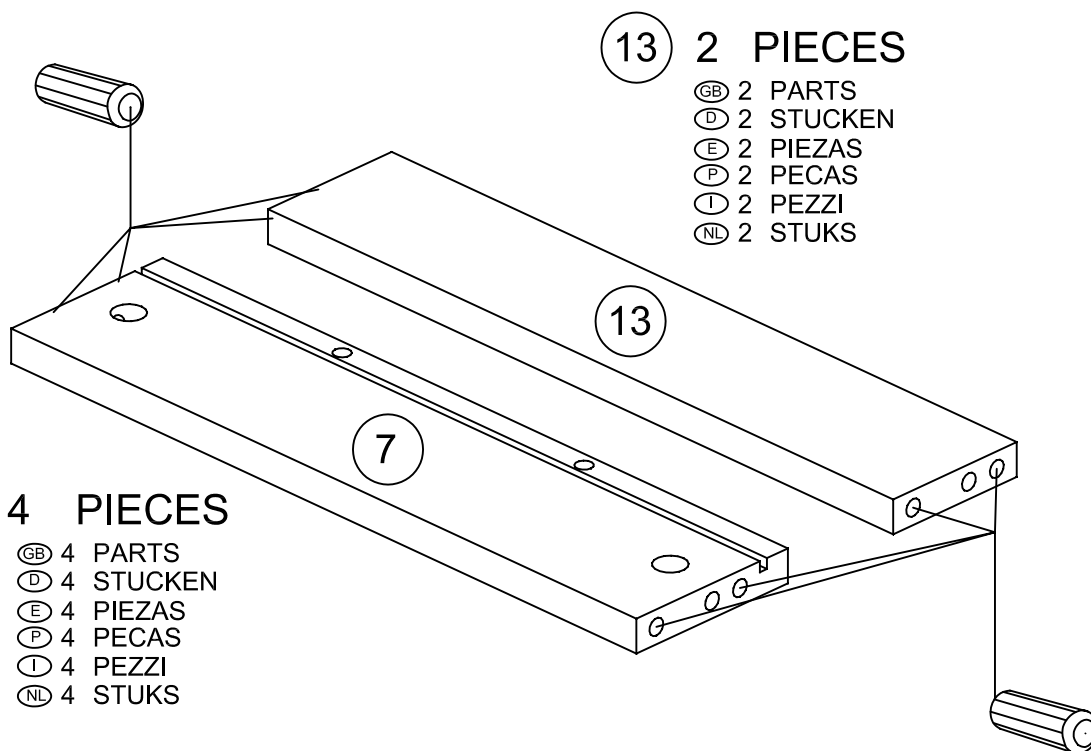

13 2 PIECES

- Ⓒ 2 PARTS
- Ⓓ 2 STÜCKEN
- Ⓔ 2 PIEZAS
- Ⓕ 2 PECAS
- Ⓖ 2 PEZZI
- Ⓗ 2 STUKS

7 4 PIECES

- Ⓒ 4 PARTS
- Ⓓ 4 STÜCKEN
- Ⓔ 4 PIEZAS
- Ⓕ 4 PECAS
- Ⓖ 4 PEZZI
- Ⓗ 4 STUKS

783911/12.5

9

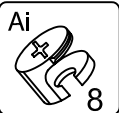

MAINTENIR

- Ⓒ TO HOLD
- Ⓓ ZUSAMMENHALTEN
- Ⓔ SOSTENER
- Ⓕ SEGURAR
- Ⓖ MANTENER
- Ⓝ IN STAND HOUDEN

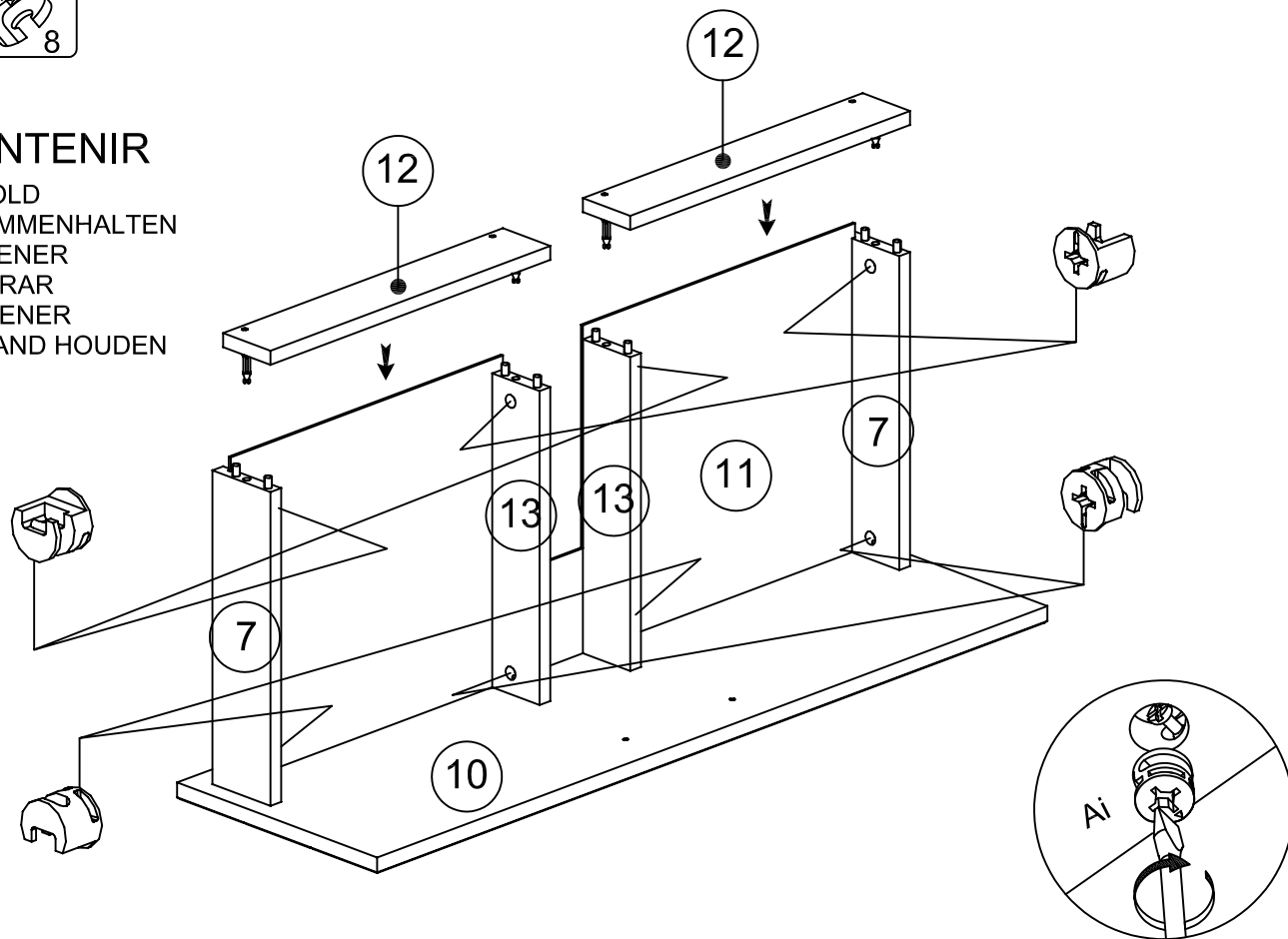

10

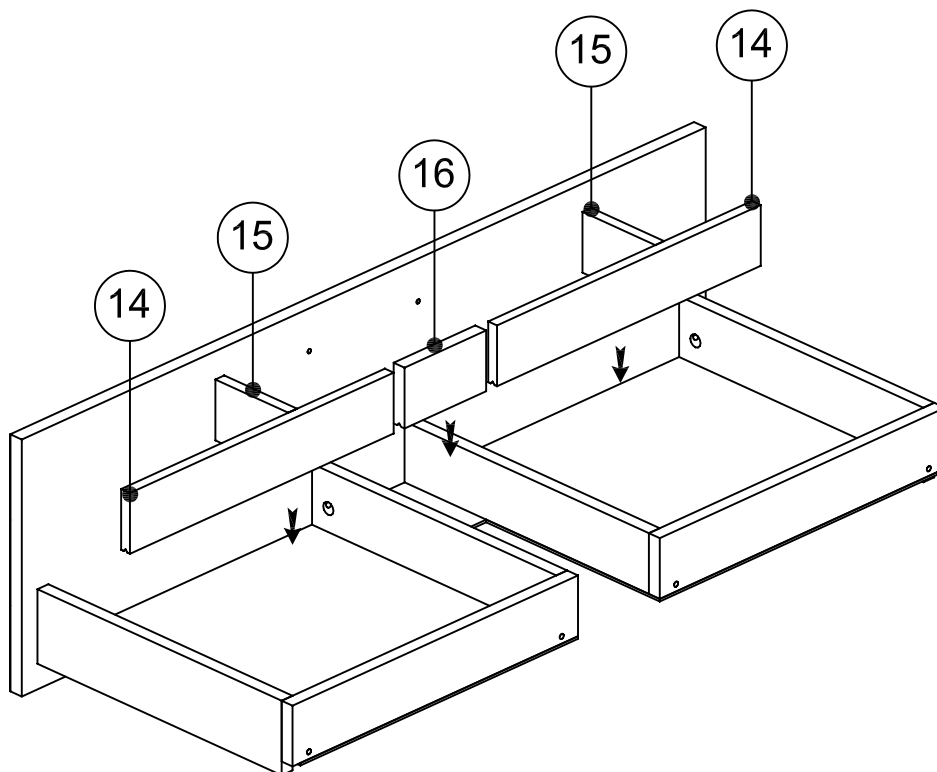

11

VI

3.5 X 15



16

MAINTENIR

- Ⓒ TO HOLD
- Ⓓ ZUSAMMENHALTEN
- Ⓔ SOSTENER
- Ⓕ SEGURAR
- Ⓖ MANTENER
- Ⓝ IN STAND HOUDEN

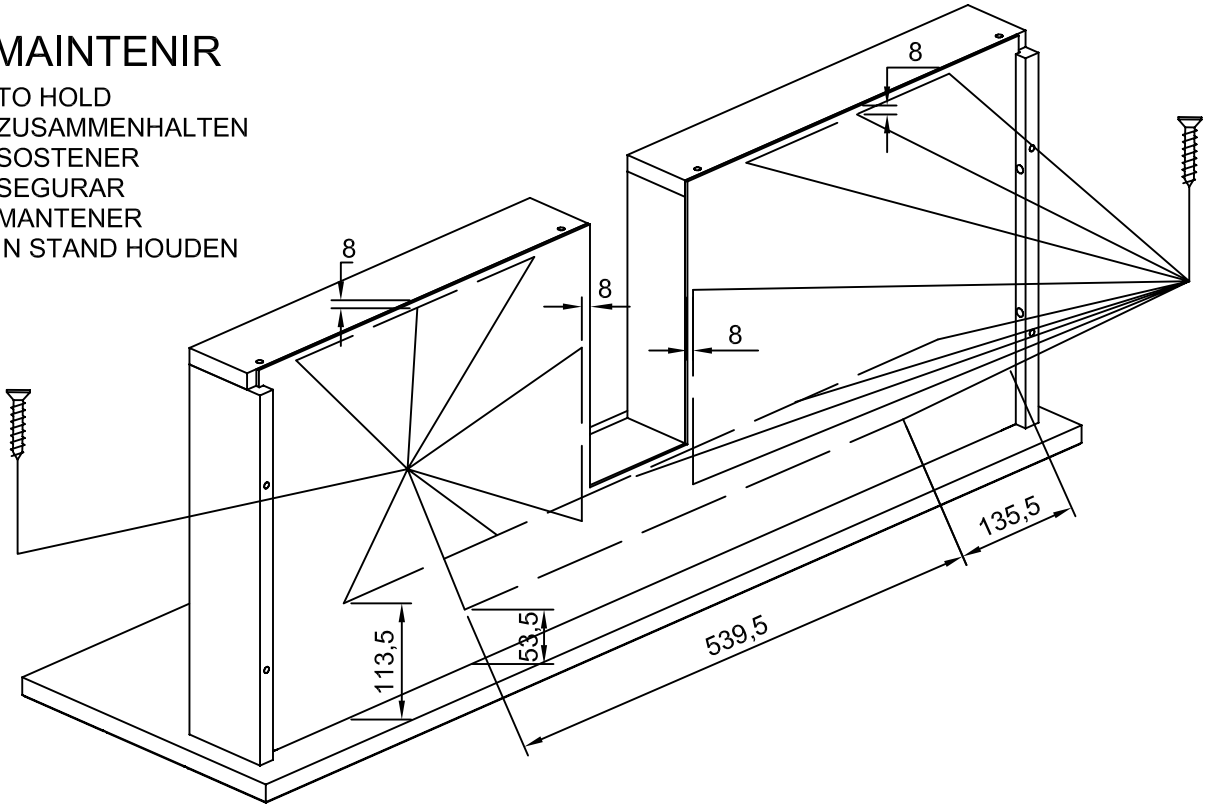

12

P01

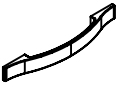

1

WT



2

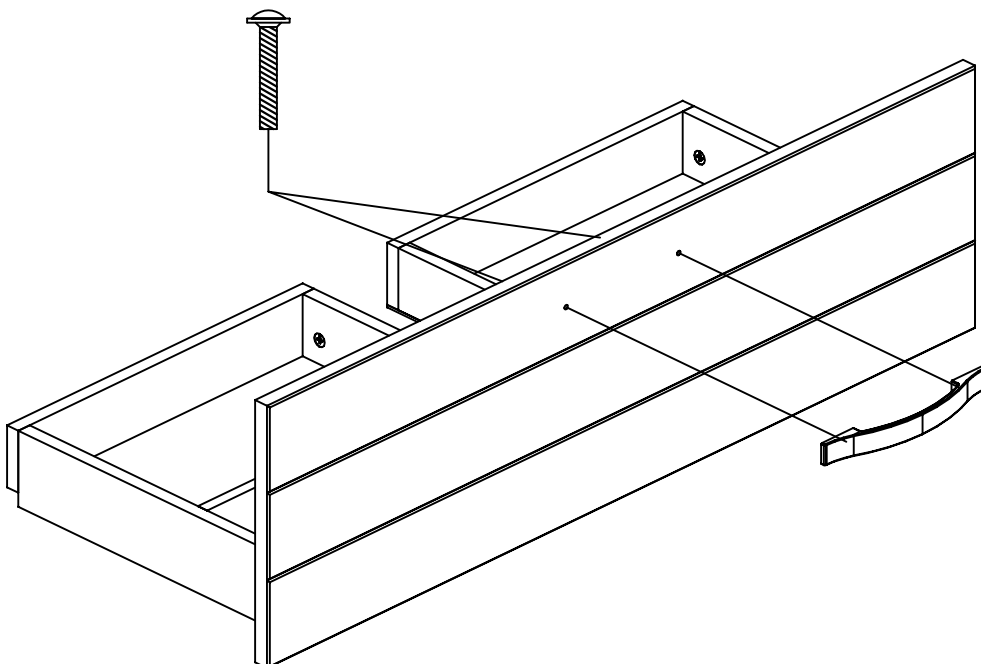

13

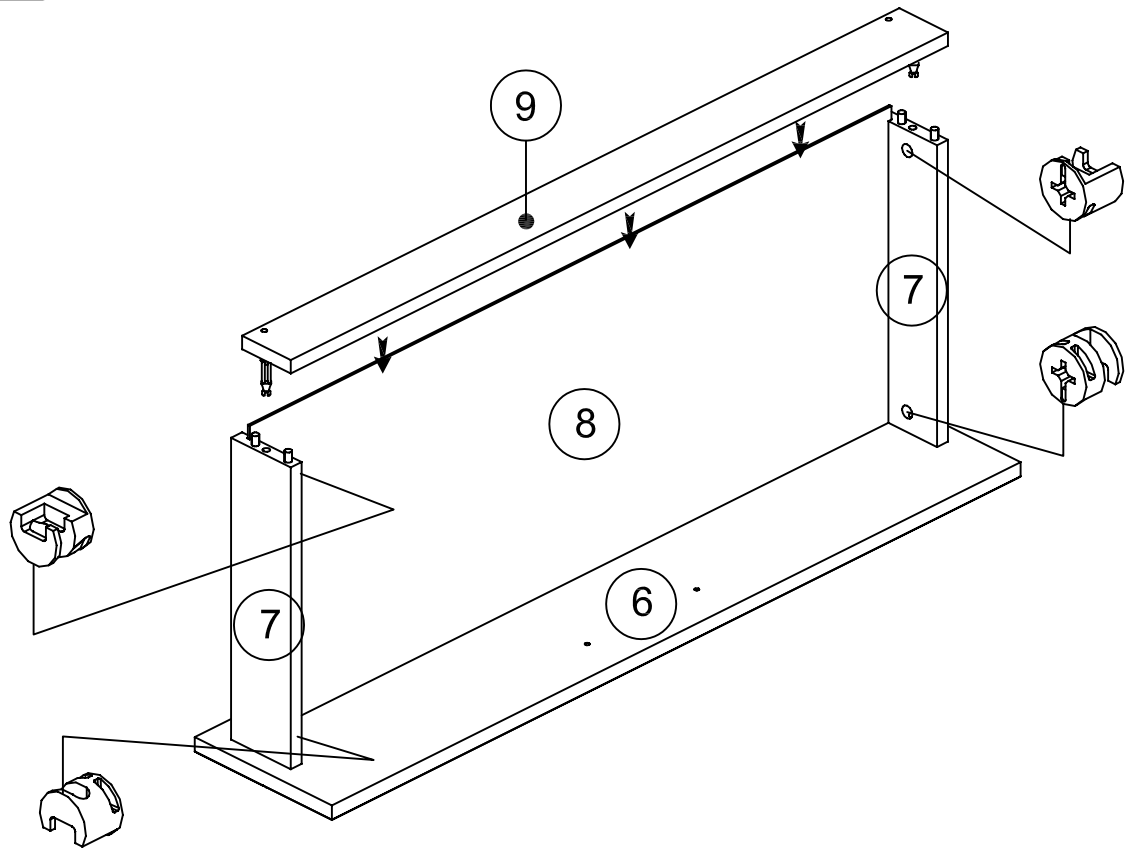
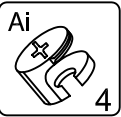

14

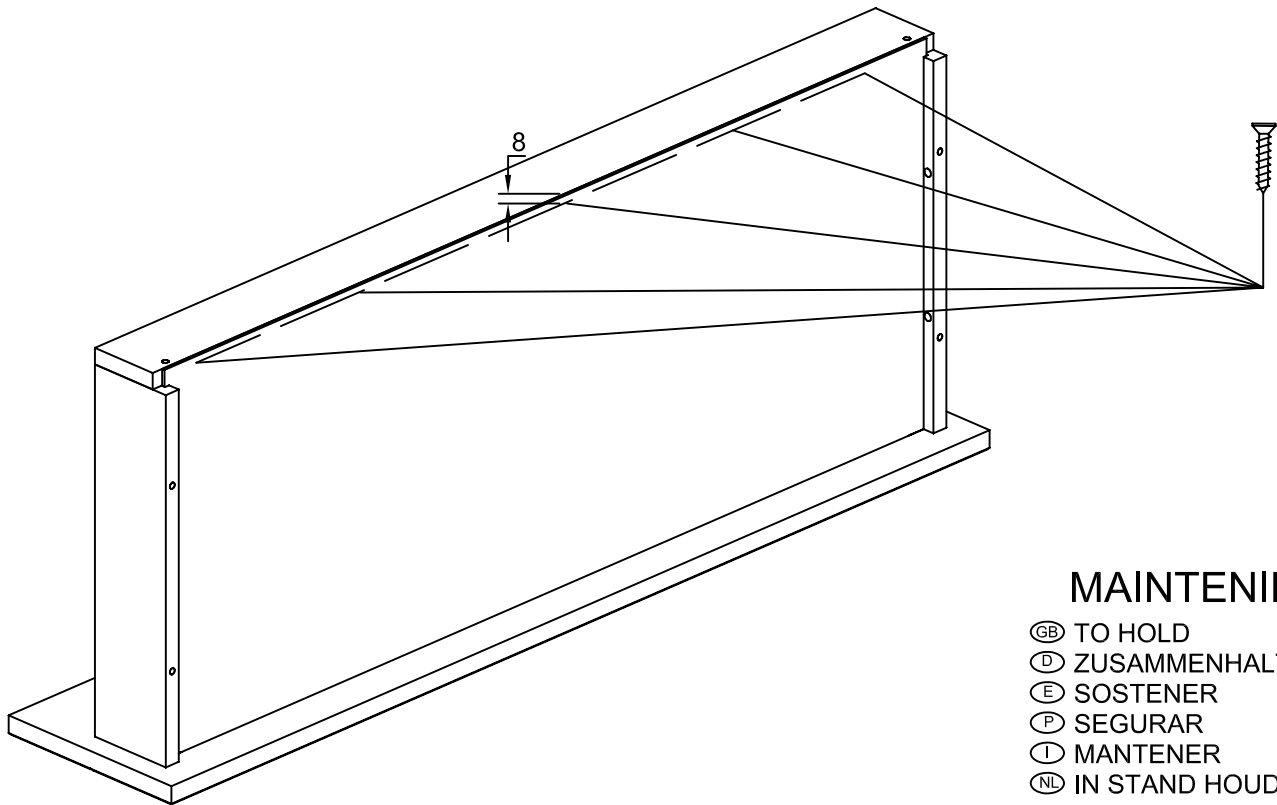
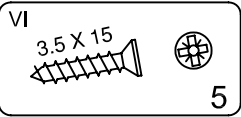

MAINTENIR

- Ⓒ TO HOLD
- Ⓓ ZUSAMMENHALTEN
- Ⓔ SOSTENER
- Ⓕ SEGURAR
- Ⓖ MANTENER
- Ⓝ IN STAND HOUDEN

15

P01



1

WT



2

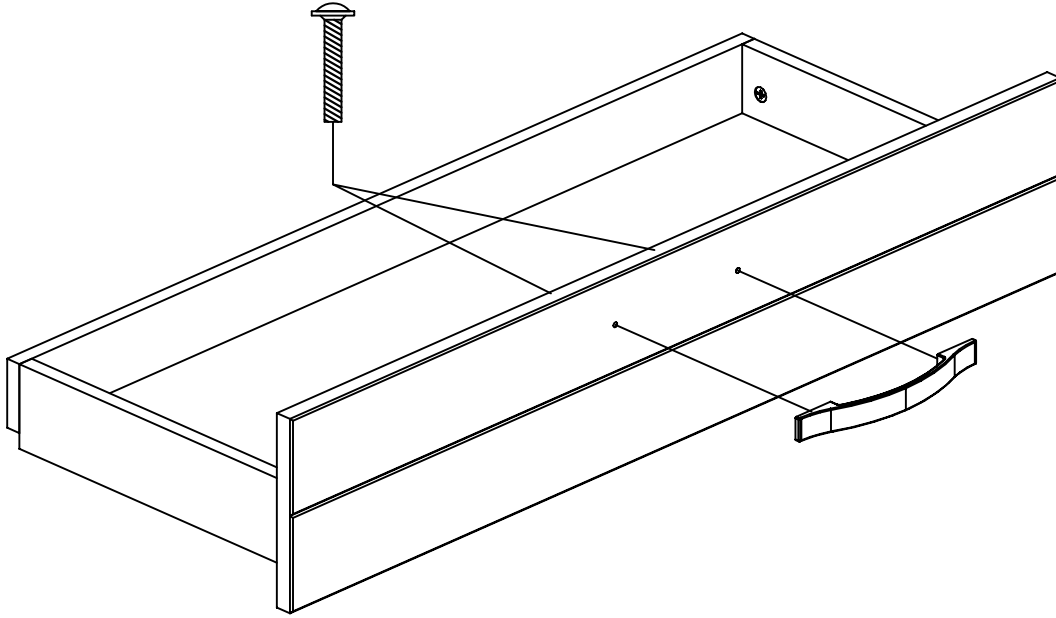

16

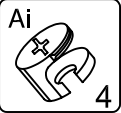

4

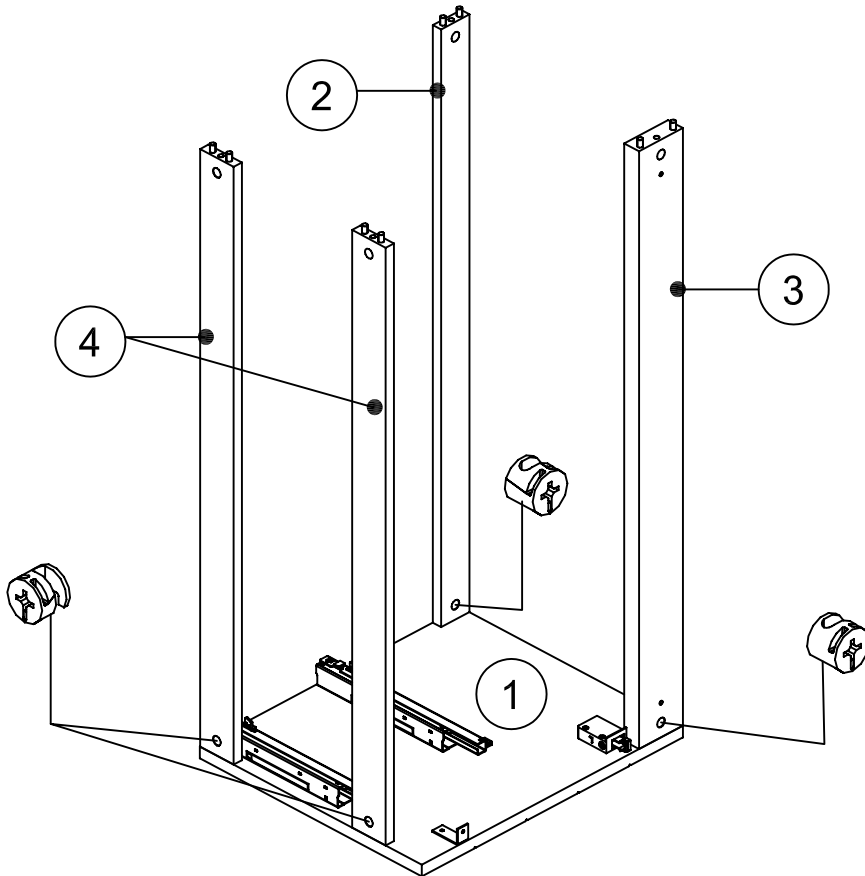

MAINTENIR

- Ⓒ TO HOLD
- Ⓓ ZUSAMMENHALTEN
- Ⓔ SOSTENER
- Ⓖ SEGURAR
- Ⓜ MANTENER
- Ⓝ IN STAND HOUDEN

17

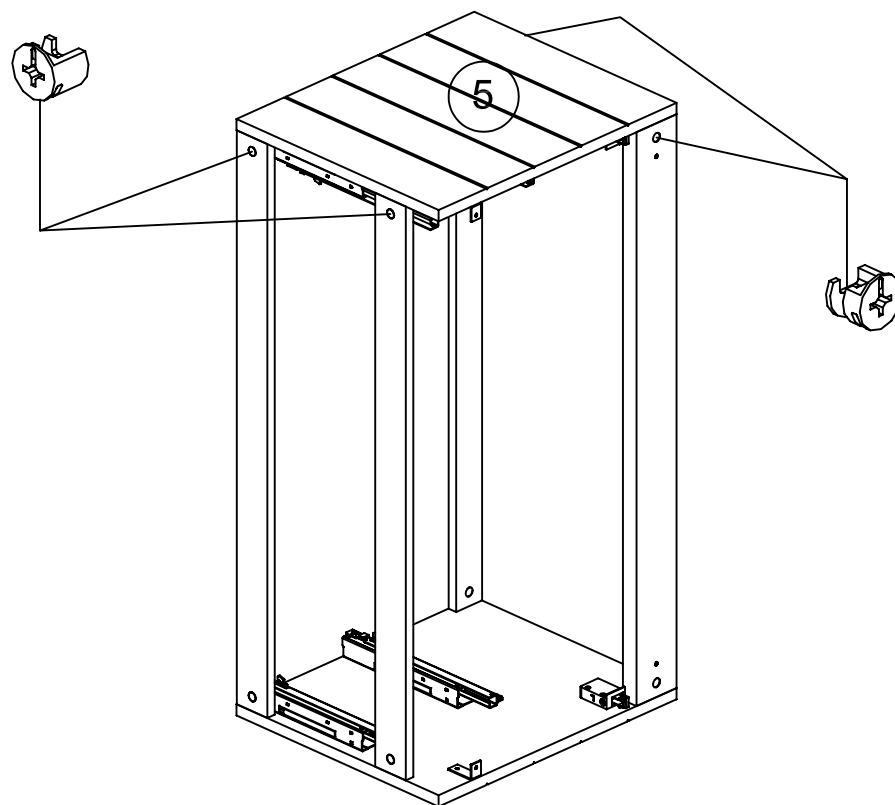
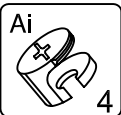

18

FIXATION DU MEUBLE AU MUR

Ce meuble peut représenter un danger pour la sécurité des personnes si sa fixation au mur a été faite de façon incorrecte.
Cette fixation doit être réalisée par une personne compétente qui s'assurera de l'adéquation entre le dispositif de fixation et le mur.

GB - FIXING CABINET TO THE WALL

This cabinet may be dangerous if it has been incorrectly fixed to the wall.
It must be fixed by a skilled individual who will check that the fixing material and the wall are appropriate.

D - BEFESTIGUNG DES MÖBELS AN DER WAND

Dieses Möbel kann eine Gefahr für die Personensicherheit darstellen, wenn seine Befestigung an der Wand nicht korrekt erfolgt.
Diese Befestigung muß von einer kompetenten Person durchgeführt werden, die sich von der Angemessenheit zwischen der Befestigungsvorrichtung und der Wand vergewissern muß.

E - FIJACIÓN DEL MUEBLE AL MURO

Este mueble puede representar un peligro para la seguridad de las personas si se lo ha fijado al muro de manera incorrecta.
Una persona competente debe realizar la fijación, quien se asegurará de la adecuación entre el dispositivo de fijación y el muro.

P - FIXAÇÃO DO MÓVEL NA PAREDE

Este móvel pode representar um perigo para a segurança das pessoas se a sua fixação na parede for feita de maneira incorrecta.
Esta fixação deve ser efectuada por uma pessoa competente que verificará a adequação entre o dispositivo de fixação e a parede.

I - FISSAZIONE DEL MOBILE AL MURO

Questo mobile può rappresentare un pericolo per la sicurezza delle persone se la fissazione al muro non viene realizzata correttamente.
La fissazione va effettuata da persona competente previo accertamento dell'adeguatezza fra il dispositivo di fissazione ed il muro.

NL - BEVESTIGING VAN HET MEUBEL AAN DE MUUR

Indien dit meubel niet op correcte wijze aan de muur bevestigd wordt, kan het gevaar voor uw veiligheid opleveren.

De bevestiging dient te worden uitgevoerd door een bevoegd persoon die zich ervan dient te vergewissen dat de muur geschikt is voor het bevestigingssysteem.

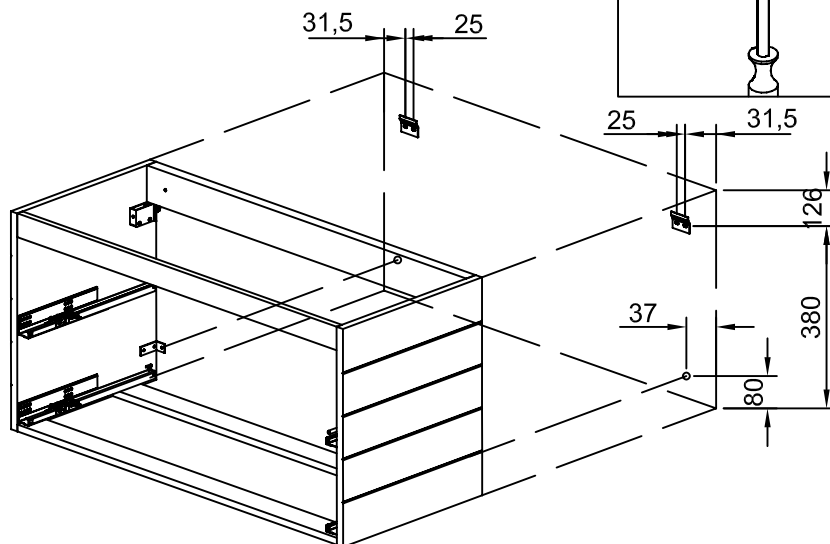
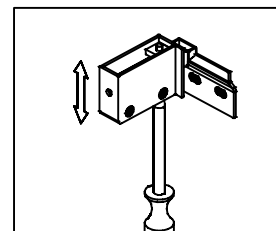
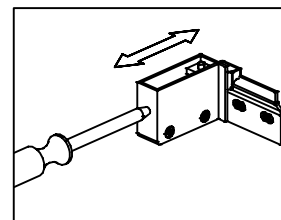
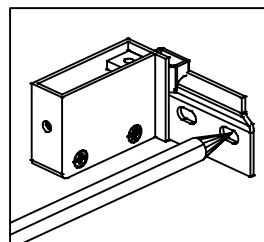

783911/12.10

19

Encombrement maximum

- Ⓒ - maximum congestion
- Ⓓ - maximal uberlastung
- Ⓔ - la congestion màxima
- Ⓖ - maximo de congestionamento
- Ⓘ - della congestione
- Ⓝ - maximale congestie

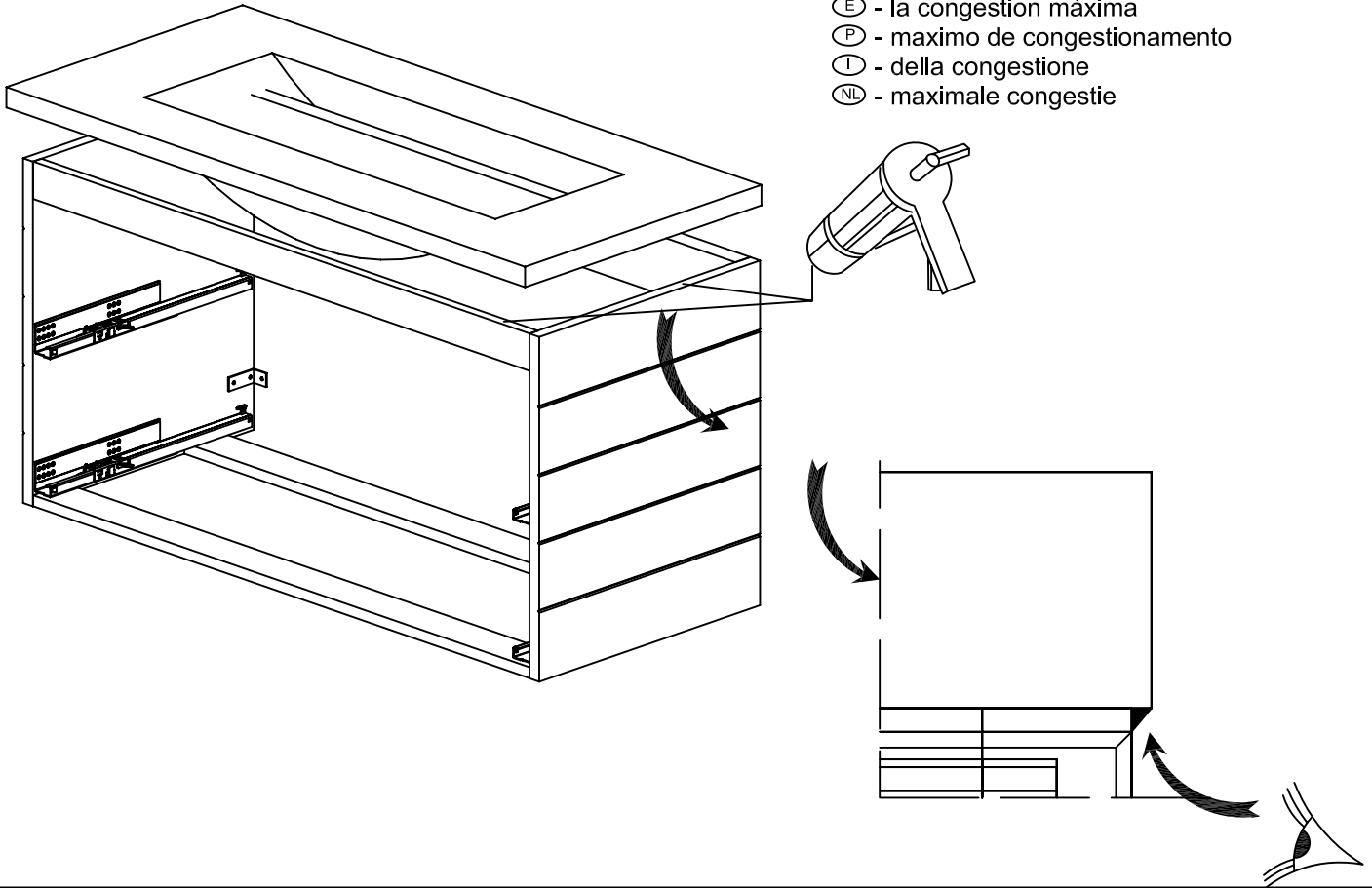

20

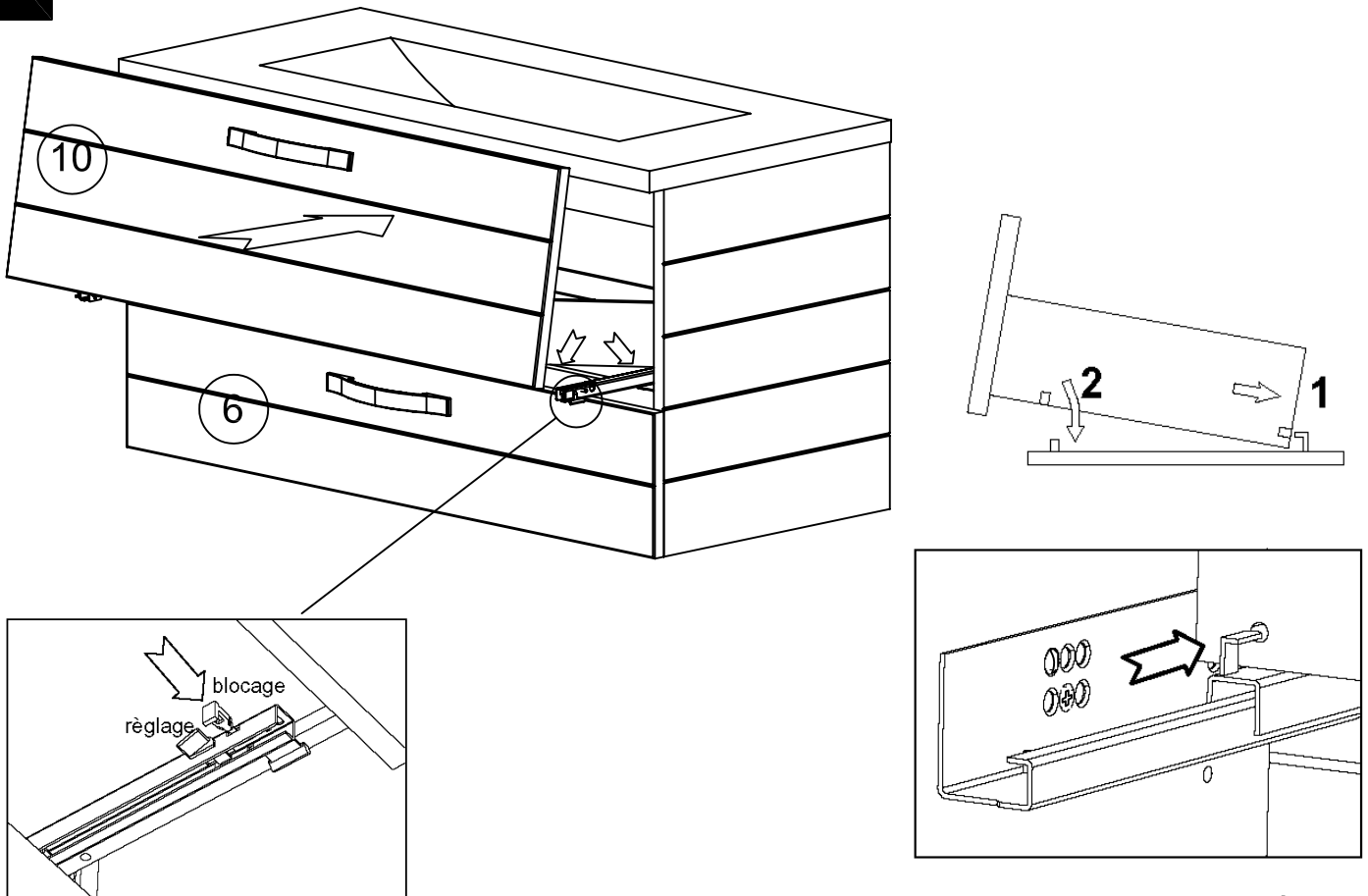

789911/12.11



ENTRETIEN

Avant de nettoyer, dépoussiérer soigneusement avec un chiffon doux et propre.

Mettre le produit sur le chiffon plutôt que sur le meuble.

Ne jamais mouiller copieusement.

Ne jamais utiliser de poudre ou éponges à récurer, de laine d'acier ou de lessive décapante.

Dépoussiérer les coulisses de tiroir et lubrifier les axes de charnières.

GB - MAINTENANCE

Before cleaning, carefully dust with a clean, soft cloth.

Put any dusting product on the cloth rather than on the cabinet.

Avoid overly wetting.

Never use scouring powders or sponges, steel wool or abrasive cleaning products.

Dust drawer slides and lubricate hinges.

D - WARTUNG

Vor Reinigung sorgfältig mit einem weichen und sauberen Tuch abstauben.

Das Produkt lieber auf das Tuch als auf das Möbel geben.

Nicht zu stark befeuchten.

Keine Scheuerpulver oder -schwämme, Stahlwolle oder Beizmittel verwenden.

Die Schubladengleitschienen abstauben, und die Scharnierachsen schmieren.

E - LIMPIEZA

Antes de limpiar, retirar el polvo cuidadosamente con un trapo suave y limpio.

Colocar el producto de limpieza más bien en el trapo que en el mueble.

Jamás mojar abundantemente.

Jamás utilizar polvos detergentes, esponjas abrasivas, lana de acero ni detergente decapante.

Sacar el polvo de las correderas del cajón y lubricar los ejes de las bisagras.

P - LIMPEZA

Antes de limpar, limpe cuidadosamente o pó com um pano macio e limpo.

Pôr o produto no pano e não sobre o móvel.

Nunca molhe muito o pano.

Nunca utilize pó ou esponjas de arear, lâ de aço ou sabão em pó decapante.

Limpe o pó das corredeiras das gavetas e lubrifique os eixos de dobradiças.

I - MANUTENZIONE

Prima di pulire, spolverare con cura con un panno morbido e pulito.

Mettere di preferenza il prodotto sul panno e non sul mobile.

Non bagnare mai copiosamente.

Non usare mai detersivi o spugne abrasivi, lana d'acciaio, prodotti per decappaggio.

Spolverare le guide dei cassetti e lubrificare gli assi delle cerniere.

NL - ONDERHOUD

Voor het reinigen zorgvuldig afstoffen met een schone, zachte doek.

Breng het product liever aan op de doek dan rechtstreeks op het meubel.

Nimmer teveel water gebruiken.

Nimmer schuurpoeder, schuurspoonsjes, staalwol of afbijtmiddelen gebruiken.

Maak de ladelopers stofvrij en smeet de scharnierpenen.

SERVICE APRES-VENTE

Si malgré l'attention particulière que nous avons apportée à ce colis, son contenu ne vous donnait pas entière satisfaction, signalez au point de vente où vous avez effectué votre achat:

*le numéro du panneau ou de la pièce de quincaillerie

*le numéro de la notice

*la référence du meuble figurant sur le colis

Ces trois éléments nous sont nécessaires pour vous assurer un service précis.

GB - AFTER SALES SERVICE

Despite the care taken in our packaging of this product, should its contents not meet with your complete satisfaction, please inform the sales outlet where the purchase was made indicating:

- the panel number or hardware item number

- the number on the assembly instructions sheet

- the reference of the cabinet on the package.

These three items are necessary to provide quick and precise after sales service.

D - KUNDENDIENST

Sollte der Inhalt des Pakets Sie trotz aller unserer Aufmerksamkeit nicht völlig zufriedenstellen, teilen Sie Ihrer Verkaufsstelle bitte folgende Auskünfte mit:

- Nummer der Platte oder des Beschlags

- Nummer der Anleitung

- Auf dem Paket angegebene Bestellnummer des Möbels

Wir benötigen diese drei Angaben, um präzisen und schnellen Kundendienst zu gewährleisten.

E - SERVICIO POSVENTA

Si a pesar de la atención particular con que hemos realizado este paquete, su contenido no le diera entera satisfacción, señalar al punto de venta donde ha hecho su compra:

- el número del panel o de la pieza de ferretería

- el número del folleto explicativo

- la referencia del mueble que figura en paquete

Necesitamos estos tres elementos para garantizarle un servicio preciso y rápido.

P - SERVIÇO PÓS-VENDA

Se, apesar da atenção especial com que preparámos a encomenda, o seu conteúdo não lhe der inteira satisfação, comunique ao ponto de venda onde efectuou a sua compra:

-o número da tábuia ou da peça metálica

- o número do folheto

- a referência do móvel indicada na embalagem

Estes três elementos são necessários para que asseguremos um serviço preciso e rápido.

I - ASSISTENZA TECNICA

Qualora, nonostante tutta la cura apportata alla confezione del collo, il contenuto dello stesso non vi desse intera soddisfazione, segnalate al punto vendita in cui avete effettuato l'acquisto:

- il numero de pannello o del pezzo di ferramenta

- il numero delle istruzioni

- la referenza del mobile riportata sul collo

Questi tre elementi sono necessari per garantire un servizio rapido e preciso.

NL - SERVICEDIENST

Indien u, ondanks de zorg die wij aan de inhoud van dit pakket hebben besteed, niet geheel tevreden bent over de inhoud, dient u de navolgende gegevens door te geven aan het verkooppunt waar u de aankoop gedaan hebt:

- het nummer van het bewuste paneel of ijzerbeslag

- het nummer van de handleiding

- het op het pakket vermelde referentienummer van het meubel

Wij hebben deze 3 gegevens nodig om u een accurate en snelle service te kunnen garanderen.