

LE COUCHAGE EN HAUTEUR NE CONVIENT PAS
AUX ENFANTS DE MOINS DE 6 ANS

- (GB) THIS BED DOES NOT FIT
CHILDREN UNDER 6 YEARS OLD
- (D) DIE HOHE DER LIEGEFLACHE IST NICHT GEEIGNET
FÜR KINDER UNTER 6 JAHREN!
- (E) EN LAS LITERAS LA CAMA SUPERIOR NO CONVIERNE
A LOS MINOS MENORES DE 6 AÑOS
- (P) CAMA E ALTURA MAO CONVEM
AS CRIANÇAS DE MENOS DE 6 ANOS
- (I) IL PETTO IN ALTEZZA NON CONVIERNE
A BAMBINI SOTTO 6 ANNI!
- (NL) DEZE HOOGSLAPER IS NIET GESCHIKT
VOOR KINDEREN MINDER DAN 6 JAAR



Caractéristiques produit :

Structure en panneau de particules
revêtu mélamine blanc et chants mélamine et ABS Gris.

Porte et pans hauts en panneau de particules
revêtu mélamine blanc avec sérigraphie
et chants mélamine et ABS Gris.

Porte en panneau de particules revêtu mélamine gris
et chants mélamine et ABS Gris.

Couchage en cm : 90 x 200 (sans literie).

Boutons en ABS, finition Gris et Blanc.

A monter soi-même.

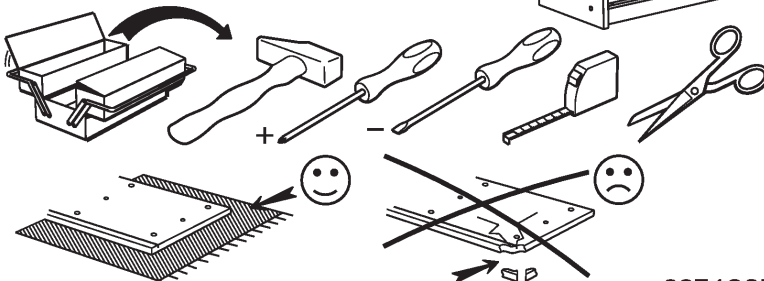
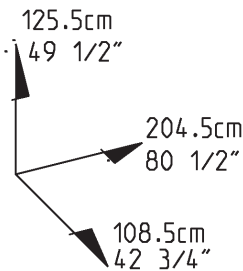
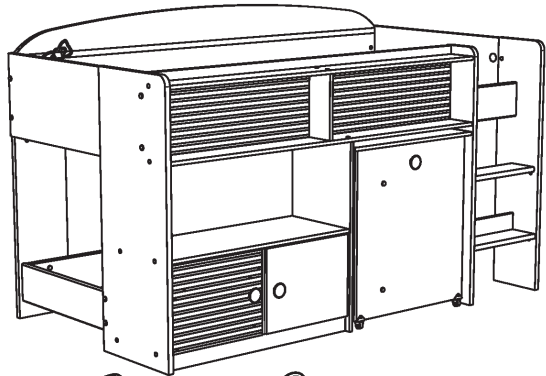

FR NOTICE D'EMPLOI

IMPORTANT – LIRE ATTENTIVEMENT – A CONSERVER POUR RÉFÉRENCE ULTÉRIEURE

1. Utiliser les outils indiqués sur la notice de montage et suivre les instructions d'assemblage.
2. Il convient que tous les dispositifs d'assemblage soient toujours convenablement serrés et régulièrement vérifiés, ainsi que resserrés si nécessaire.
3. Le positionnement et le moyen d'accès au lit sont indiqués sur la notice de montage.
4. Respecter l'épaisseur maximale du matelas, voir le marquage sur la notice de montage.
5. Taille du matelas recommandé 1980 mm x 880 mm x 150 mm maximum.
6. Il convient de ne pas utiliser le lit surélevé lorsqu'une partie de la structure manque ou est cassée
7. Les lits surélevés ne conviennent pas aux enfants de moins de 6 ans, en raison des risques de blessures dues aux chutes
8. Attention aux articles tels que des cordes, des ficelles, des cordons, des harnais et des ceintures attachés ou accroché sur un lit superposé ou surélevé afin d'éviter aux enfants de s'étrangler.
9. Avertissement «Les enfant peuvent se retrouver piégés entre le lit et le mur. Pour éviter le risque de blessure grave la distance entre la barrière de sécurité supérieure et le mur ne doit pas excéder 75 mm ou doit être d'au moins 230 mm»
10. Conforme à la norme NF D62-019-1 et NF D62-019-2 de 1994.
11. Ne jamais laisser des enfants sans un minimum de surveillance
12. Aucun jeu brutal ne doit être permis dans et sous le lit haut.
13. Il est interdit d'avoir plus d'une personne dans le lit haut.
14. Ne pas permettre aux enfants de se basculer ou de sauter sur ou sous le lit.
15. Utiliser toujours l'échelle pour monter ou descendre du lit haut.
16. Ne pas remplacer les pièces originales par des substitutions. Obtenir les pièces de rechange du magasin ou du fabricant.
17. L'utilisation d'une veilleuse de nuit peut procurer plus de sécurité à l'enfant couchant dans le lit haut.

GB DIRECTIONS FOR USE

IMPORTANT – PLEASE READ CAREFULLY – KEEP FOR FUTURE REFERENCE

1. Use the tools indicated on the assembly leaflet and follow the instructions.
2. All assembly components must always be tightened properly. Check regularly and retighten if necessary.
3. The positioning and means of access to the bed are indicated on the assembly leaflet.
4. Do not exceed the maximum mattress thickness. Refer to the marking on the assembly leaflet.
5. Maximum recommended mattress size: 1980 mm x 880 mm x 150 mm
6. The high sleeper must not be used if a part of the structure is missing or broken.

7. High sleepers are not suited to children below the age of 6 years due to the risk of injury in the event of a fall.
8. Do not attach or suspend items such as ropes, strings, cords, harnesses and belts on a bunk-bed or high sleeper to avoid the possibility of strangulation.
9. Warning: Children may become trapped between the bed and the wall. To avoid the risk of serious injury, the distance between the top safety barrier and the wall must not exceed 75 mm or must be at least 230 mm.
10. Compliant with Standard NF D62-019-1 and NF D62-019-2 of 1994.
11. Never leave children without a minimum of supervision.
12. Children must not be allowed to play roughly on or under the top bunk.
13. It is forbidden to have more than one person in the top bunk.
14. Do not allow children to swing or jump on or under the bed.
15. Always use the ladder to climb up to and down from the top bunk.
16. Do not replace original parts with substitutes. Spare parts must be obtained from the store or manufacturer.
17. Use of a night-light will improve safety for a child sleeping in the top bunk.

DE GEBRAUCHSANWEISUNG

WICHTIG – AUFMERKSAM LESEN UND AUFBEWAHREN

1. Die in der Montage Anleitung angeführten Werkzeuge benutzen, die Montagehinweise beachten.
2. Alle Elemente müssen korrekt verbunden und angezogen (notfalls nachziehen) sein und regelmäßig überprüft werden.
3. Die Position und der Zugang zum Bett sind in der Montageanleitung aufgeführt.
4. Die maximale Stärke der Matratze einhalten, siehe die Markierungen in der Montageanleitung.
5. Empfohlene Abmessungen der zu Matratze 1980 mm x 880 mm x 150 mm maximal
6. Das Etagenbett darf nicht benutzt werden wenn die Struktur oder ein Teil der Struktur fehlt oder beschädigt ist.
7. Die Etagenbetten sind nicht für Kinder unter 6 Jahren geeignet (Verletzungs- und Unfallgefahr)
8. Vorsicht ist weiterhin geboten mit am Etagenbett befestigten Seilen, Kordeln, Bändern, oder Sicherheitsgeschirr, hier besteht Strangulierungsgefahr für Kinder.
9. Warnung « Kinder können sich zwischen dem Bett und der Wand eingeklemmt finden. Um Unfälle zu vermeiden, darf der Abstand zwischen der oberen Sicherheitsleiste und der Wand nicht mehr als 75 mm betragen oder muß wenigstens 230 mm betragen.
10. Entsprechend der Norm NF D62-019-1 und NF D62-019-2 von 1994.
11. Kinder niemals ohne ein Minimum von Aufsicht lassen.
12. Brutale Spiele dürfen in oder auf dem oberen Bett nicht zugelassen werden.
13. Im oberen Bett darf nur eine Person schlafen.
14. Die Kinder dürfen nicht auf das Bett springen oder schaukeln.
15. Nur die Leiter zum Hinaufsteigen und Herabsteigen des oberen Bettes benutzen.
16. Nur Originalteile bei Reparaturen verwenden. Die Austauschteile nur im Fachhandel oder

beim Hersteller einkaufen.

17. Die Benutzung einer kleinen Lampe kann dem Kind im oberen Bett ein Sicherheitsgefühl verleihen.

ES INSTRUCCIONES DE USO

IMPORTANTE – LEA ATENTAMENTE – CONSÉRVELAS PARA POSTERIORES CONSULTAS

1. Utilizar las herramientas indicadas en las instrucciones de montaje y seguir éstas últimas.
2. Es conveniente que todos los dispositivos de ensamblaje estén siempre adecuadamente apretados y periódicamente verificados, y vueltos a apretar si fuera necesario.
3. El posicionamiento y el medio de acceso a la cama vienen indicados en las instrucciones.
4. Respetar el grosor máximo del colchón, ver el marcado en las instrucciones de montaje.
5. Dimensiones del colchón recomendado 1980 mm x 880 mm x 150 mm máximo.
6. Será conveniente no utilizar la cama sobre elevada si una parte de la estructura faltara o estuviera rota
7. Las camas sobre elevadas no son aptas para los niños menores de 6 años, pues se pueden lesionar a causa de las caídas
8. Cuidado con los artículos tales como cuerdas, cordeles, arneses y cinturones atados o colgados en una cama superpuesta o sobre elevada para evitar que los niños se estrangulen.
9. Advertencia “los niños pueden verse pillados entre la cama y la pared. Para evitar el riesgo de lesiones graves, la distancia entre la barrera de seguridad superior y la pared no debe sobrepasar los 75 mm o debe ser de al menos 230 mm”
10. Conforme a la norma NF D62-019-1 y NF D62-019-2 de 1994.
11. No dejar nunca los niños sin un mínimo de vigilancia.
12. No se debe permitir ningún juego violento en la cama de arriba ni debajo de ésta.
13. Está prohibido que haya más de una persona en la cama de arriba.
14. No permitir a los niños voltearse o saltar encima o debajo de la cama.
15. Utilizar siempre la escalera para subir y bajar de la cama de arriba.
16. No sustituir las piezas originales por sustituciones. Pedir las piezas de repuesto dirigiéndose a la tienda o al fabricante.
17. La utilización de una lamparilla de noche puede proporcionar más seguridad al niño que se acuesta en la cama de arriba.

PT INSTRUÇÕES

IMPORTANTE – LER ATENTAMENTE – GUARDAR PARA REFERÊNCIA POSTERIOR

1. Utilizar as ferramentas indicadas no folheto de montagem e seguir as instruções de montagem.
2. Todos os dispositivos de montagem devem estar correctamente apertados e verificados regularmente, se necessário apertar novamente.
3. O posicionamento e o meio de acesso à cama estão indicados no folheto de montagem.

4. Respeitar a espessura máxima do colchão, ver as especificações no folheto de montagem.
5. Tamanho do colchão recomendado 1980 mm x 880 mm x 150 mm no máximo.
6. Não deve utilizar a cama alta quando falta uma parte da estrutura ou quando esta está quebrada
7. As camas altas não são adequadas para crianças com menos de 6 anos, devido aos riscos de ferimentos causados pelas quedas
8. Ter cuidado com os artigos tais como as cordas, fios, atacadores, arreios e cintos fixados ou atados numa cama alta ou beliche por forma a prevenir o risco de estrangulamento.
9. Aviso «As crianças podem ficar bloqueadas entre a cama e a parede. Para prevenir o risco de ferimentos graves, a distância entre a barreira de segurança superior e a parede não deve exceder 75 mm ou deve ser de pelo menos 230 mm»
10. Conforme à norma NF D62-019-1 e NF D62-019-2 de 1994.
11. Nunca deixar as crianças sem vigilância
12. Nenhum jogo brutal deve ser permitido em cima e debaixo da cama alta.
13. É proibido haver mais de que uma pessoa na cama alta.
14. Não deixar as crianças empurrar-se ou saltar em cima ou debaixo da cama.
15. Utilizar sempre a escada para subir ou descer da cama alta.
16. Não substituir as peças de origem por outras peças. Obter as peças sobresselentes na loja ou no fabricante.
17. A utilização de um candeeiro pode trazer mais segurança à criança que dorme na cama alta.

IT ISTRUZIONI PER L'USO

IMPORTANTE – LEGGERE ATTENTAMENTE – CONSERVARE PER FUTURA CONSULTAZIONE

1. Utilizzare gli utensili indicati sull'avviso di montaggio e seguire le istruzioni per l'assemblaggio.
2. È necessario che tutti i dispositivi di assemblaggio siano sempre opportunamente stretti e regolarmente controllati, nonché stretti nuovamente, se necessario.
3. La collocazione e il mezzo di accesso al letto sono indicati sull'avviso di montaggio.
4. Rispettare lo spessore massimo del materasso, facendo attenzione alla marchiatura sull'avviso di montaggio.
5. Misura consigliata di materasso 1980 mm x 880 mm x 150 mm massimo.
6. Si sconsiglia l'uso del lettino sopraelevato se una parte della struttura manca o è rotta.
7. I lettini sopraelevati non sono adatti a bambini di età inferiore ai 6 anni, per i rischi di lesioni dovuti a cadute.
8. Attenzione agli articoli quali corde, spaghi, cordoni, imbracature o cinture fissate o appese a un letto sovrapposto o sopraelevato, per evitare che i bambini possano strangolarsi.
9. Avvertenza: "I bambini possono trovarsi intrappolati tra il letto ed il muro. Per evitare il rischio di gravi lesioni, la distanza tra la barriera di sicurezza superiore e il muro non deve superare i 75 mm o deve essere almeno di 230 mm".
10. Conforme alla norma NF D62-019-1 e NF D62-019-2 de 1994.

11. Non lasciare mai i bambini senza un minimo di sorveglianza.
12. Non permettere alcun gioco violento sul letto alto e al di sotto di esso.
13. È vietata la presenza di più di una persona sul letto in alto.
14. Non lasciare che i bambini si dondolino o che saltino sul letto o sotto di esso.
15. Per salire sul letto in alto o per scendere da esso, servirsi sempre della scaletta.
16. Non sostituire i componenti originali con parti non originali. Procurarsi i componenti di ricambio presso il magazzino o presso il produttore.
17. L'utilizzo di una lucetta notturna può offrire maggiore sicurezza al bambino che dorme sul letto in alto.

NL GEBRUIKSAANWIJZING

BELANGRIJK – AANDACHTIG LEZEN – BEWAREN VOOR LATERE NASLAG

1. Gebruik het op de montagehandleiding aangegeven gereedschap en volg de assemblage-instructies.
2. Alle bevestigingsmiddelen van de assemblage moeten behoorlijk zijn vastgedraaid, regelmatig worden gecontroleerd en zonodig opnieuw worden aangehaald.
3. De plaatsing en de wijze van toegang tot het bed zijn op de montagehandleiding aangegeven.
4. Houd u aan de maximale matrasdikte, zie de markering op de montagehandleiding.
5. Aanbevolen matrasdikte: maximum 1980 mm x 880 mm x 150 mm .
6. Het hoge bed moet niet gebruikt worden, wanneer een deel van de structuur ontbreekt of kapot is.
7. Hoge bedden zijn niet geschikt voor kinderen onder de 6 jaar, vanwege het gevaar van verwondingen door vallen.
8. Wees voorzichtig met dingen als koorden, touwtjes, snoeren, tuigjes en gordels die vastgemaakt zijn aan een hoog bed, om te voorkomen dat kinderen gekeeld worden en stikken.
9. Waarschuwing «Kinderen kunnen klem raken tussen het bed en de muur. Om ernstige verwondingen te voorkomen, moet de afstand tussen de bovenste veiligheidsstang en de muur niet meer zijn dan 75 mm of minstens 230 mm»
10. Voldoet aan de norm NF D62-019-1 en NF D62-019-2 van 1994.
11. Laat kinderen nooit alleen zonder minimale bewaking
12. Verbied woeste spellen in en onder een verhoogd bed.
13. Er mag zich maar één persoon tegelijk in het hoge bed bevinden.
14. Laat kinderen niet wippen of springen in of onder het hoge bed.
15. Gebruik altijd de ladder om in en uit het hoge bed te klimmen.
16. Vervang de originele stukken niet door namaak. Betrek de vervangende onderdelen van uw leverancier of van de fabrikant.
17. Het gebruik van een nachtlampje kan kinderen in een verhoogd bed een veilig gevoel geven.

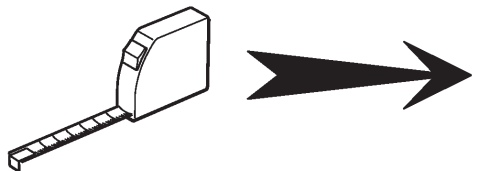
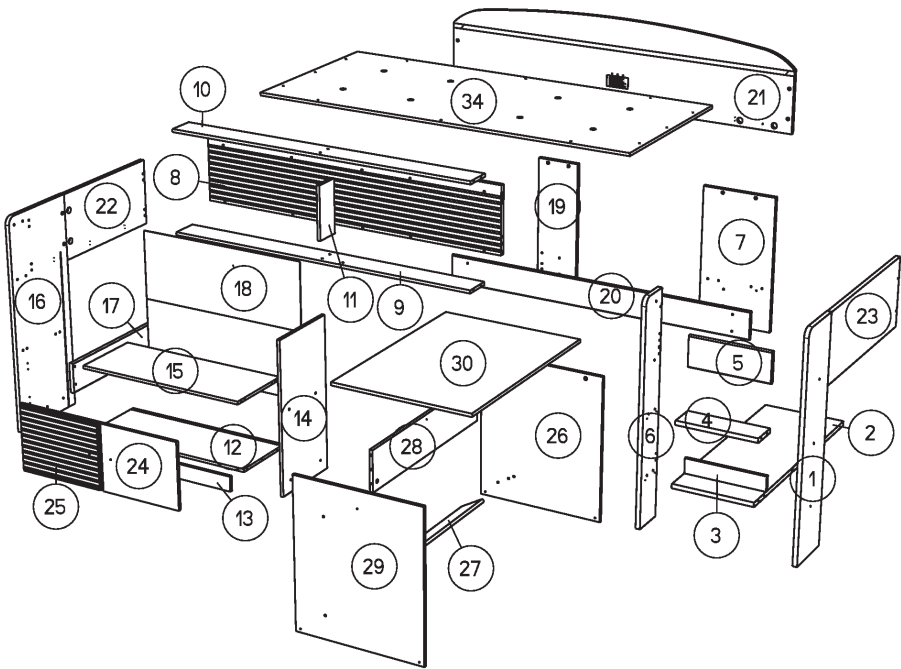

			mm			inch			
⑪	x	1	264	125	15	10	3/8	4 15/16	9/16
③	x	1	397	77	15	15	5/8	3	9/16
④	x	1	397	133	22	15	5/8	5 1/4	7/8
⑤	x	1	397	154	22	15	5/8	6 1/16	7/8
⑳	x	1	444	340	15	17	7/16	13 3/8	9/16
㉑	x	1	444	340	15	17	7/16	13 3/8	9/16
㉒	x	1	656	342	22	25	13/16	13 7/16	7/8
㉓	x	1	664	163	22	26	1/8	6 7/16	7/8
㉔	x	1	706	618	15	27	13/16	24 5/16	9/16
㉕	x	1	706	618	15	27	13/16	24 5/16	9/16
㉖	x	1	768	243	22	30	1/4	9 9/16	7/8
㉗	x	1	768	419	22	30	1/4	16 1/2	7/8
㉘	x	1	780	380	15	30	11/16	14 15/16	9/16
㉙	x	1	831	342	22	32	11/16	13 7/16	7/8
㉚	x	1	882	125	15	34	3/4	4 15/16	9/16
㉛	x	1	882	192	15	34	3/4	7 9/16	9/16
㉜	x	1	894	77	15	35	3/16	3	9/16
㉝	x	1	894	338	15	35	3/16	13 5/16	9/16
㉞	x	1	894	354	15	35	3/16	13 15/16	9/16
㉟	x	1	942	668	15	37	1/16	26 5/16	9/16
㊱	x	1	1053	397	22	41	7/16	15 5/8	7/8
㊲	x	1	1112	161	22	43	3/4	6 5/16	7/8
㊳	x	1	1112	250	22	43	3/4	9 13/16	7/8
㊴	x	1	1112	425	22	43	3/4	16 3/4	7/8
㊵	x	1	1581	131	15	62	1/4	5 3/16	9/16
㊶	x	1	1581	131	15	62	1/4	5 3/16	9/16
㊷	x	1	1581	330	22	62	1/4	13	7/8
㊸	x	1	1815	163	22	71	7/16	6 7/16	7/8
㊹	x	1	1990	890	15	78	3/8	35 1/16	9/16
㊺	x	1	2000	483	22	78	3/4	19	7/8
㉠	x	1	910	713	3	35	13/16	28 1/16	1/8

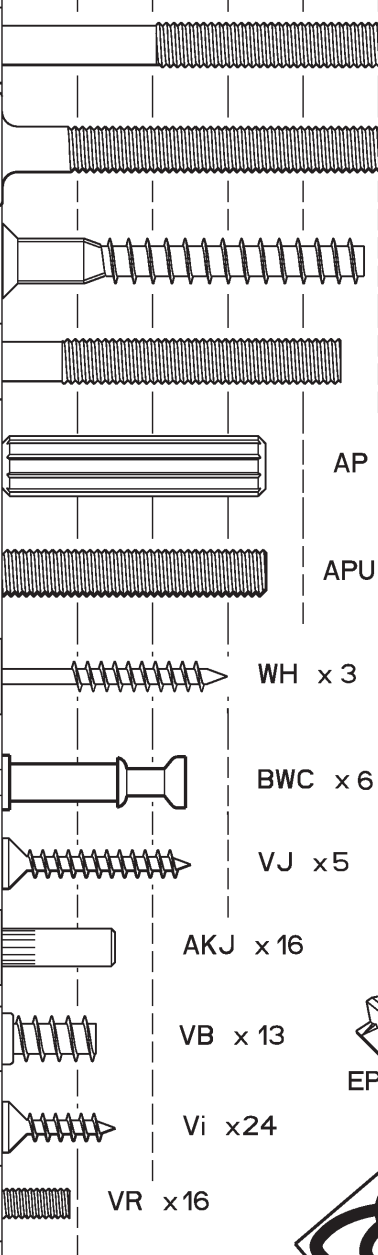
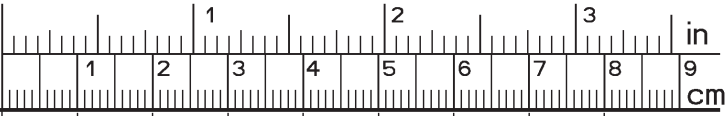

XT x1
BLZ x 19
HW x 23
VV x8
AP x 65
APU x6
WH x 3
BWC x 6
VJ x 5
AKJ x 16
VB x 13
Vi x24
VR x16

BML x22
BLL x2
AKG x 12
HV x1
BWY x 4
LN x 12
BWC x 6
BWU x4
BAG x9
SD x4
EP x3
BYX x1

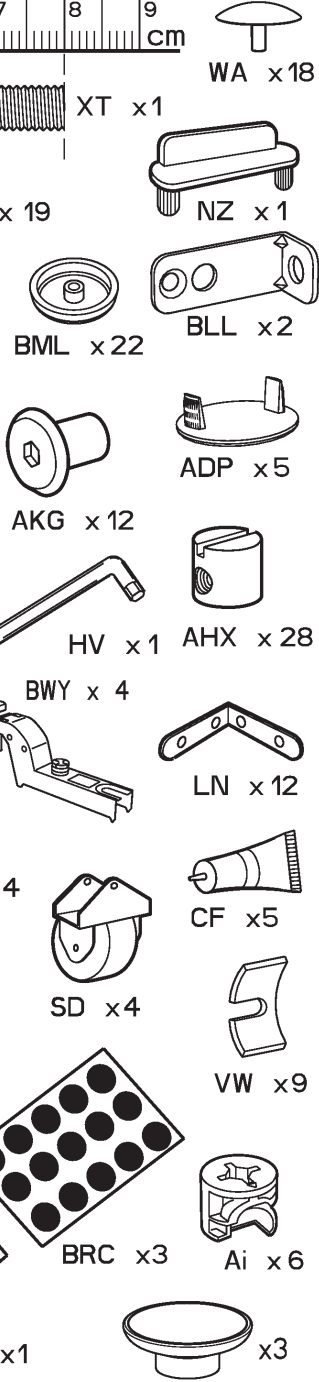

WA x18
NZ x1
ADP x5
AHX x28
LN x 12
CF x5
VW x9
Ai x6
x3



BRC x3

1

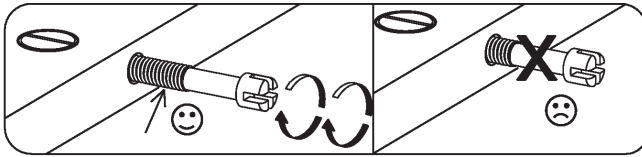
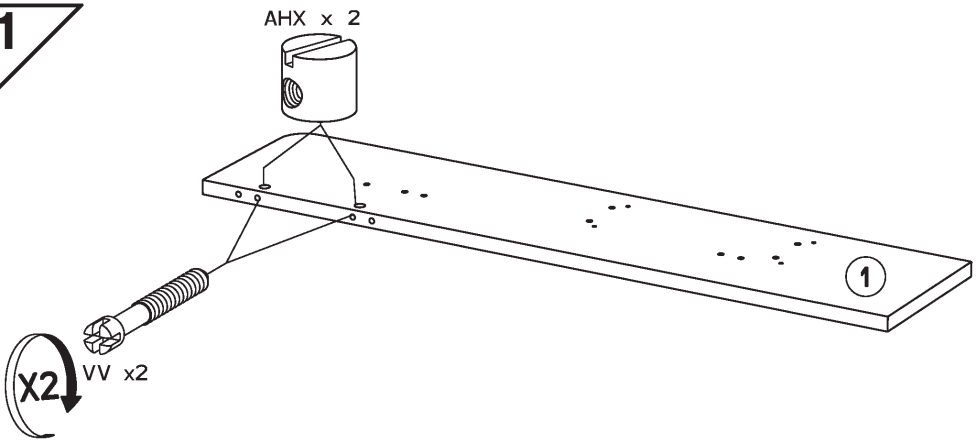

2

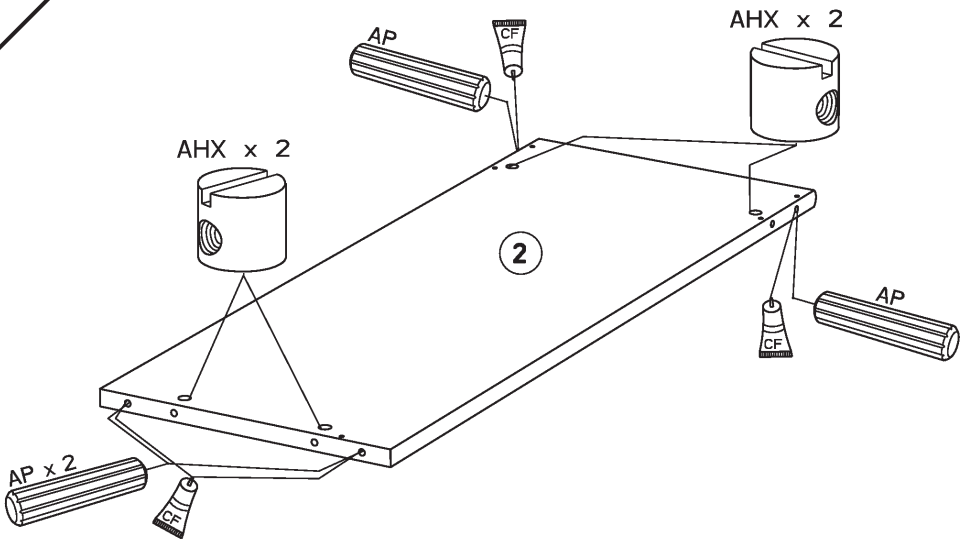

3

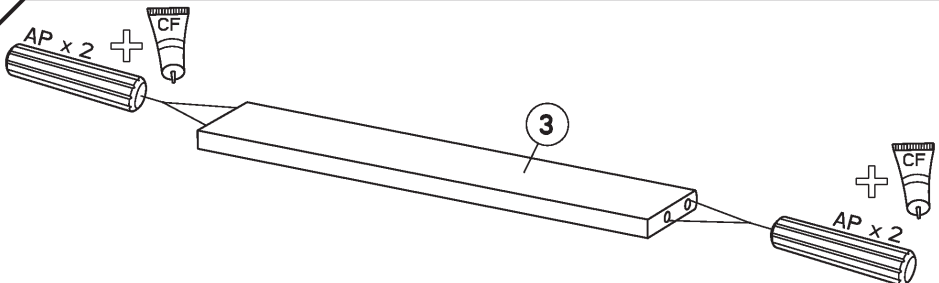

4

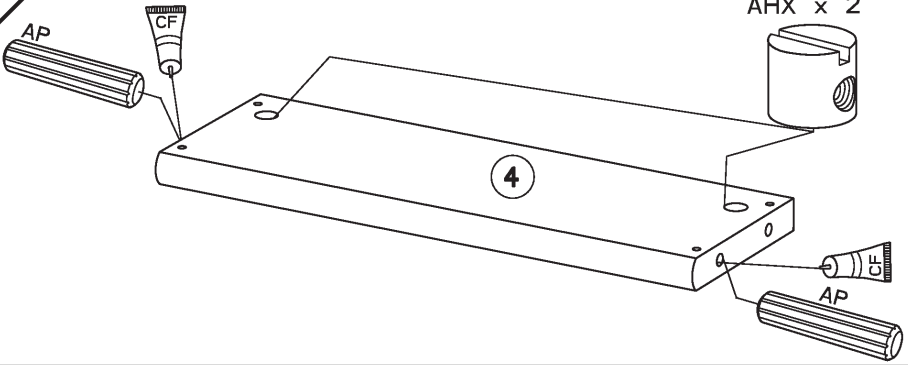

5

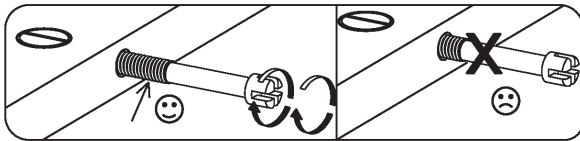
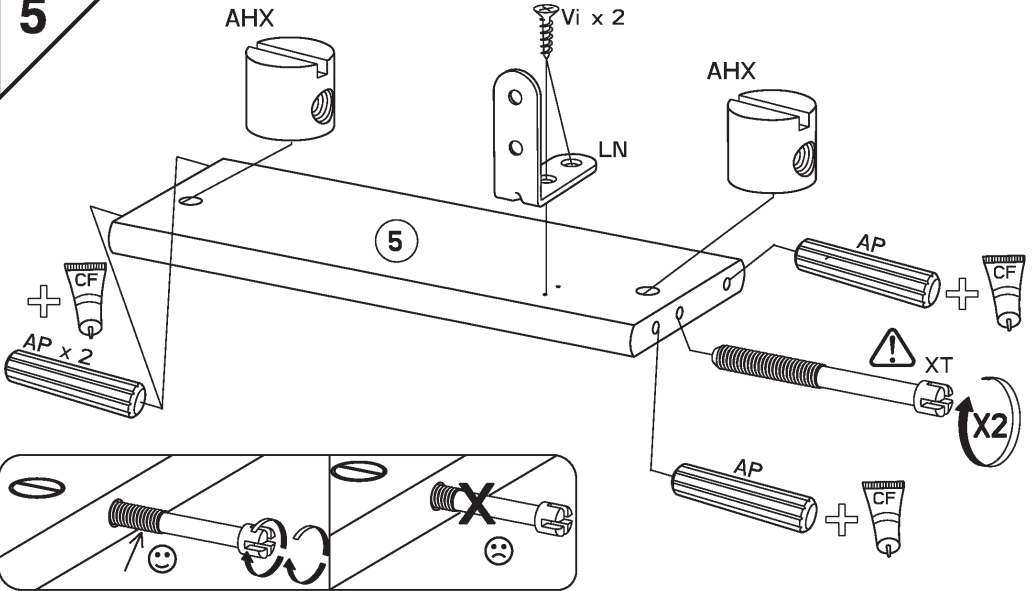

6

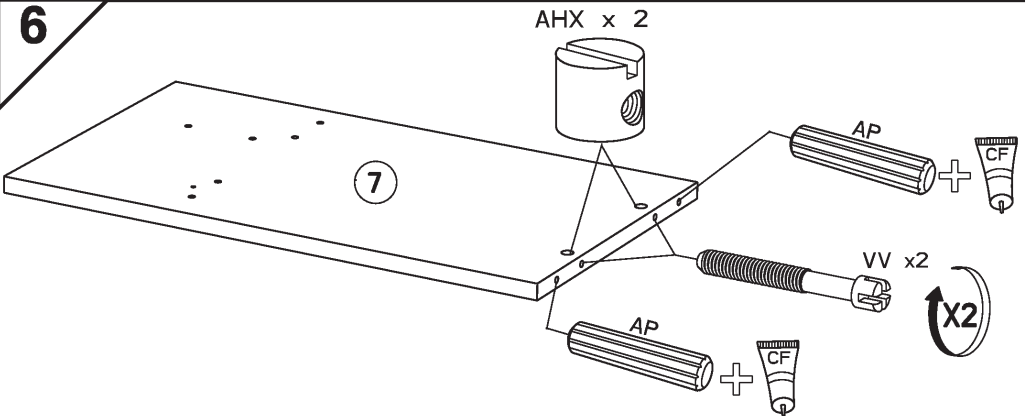

7

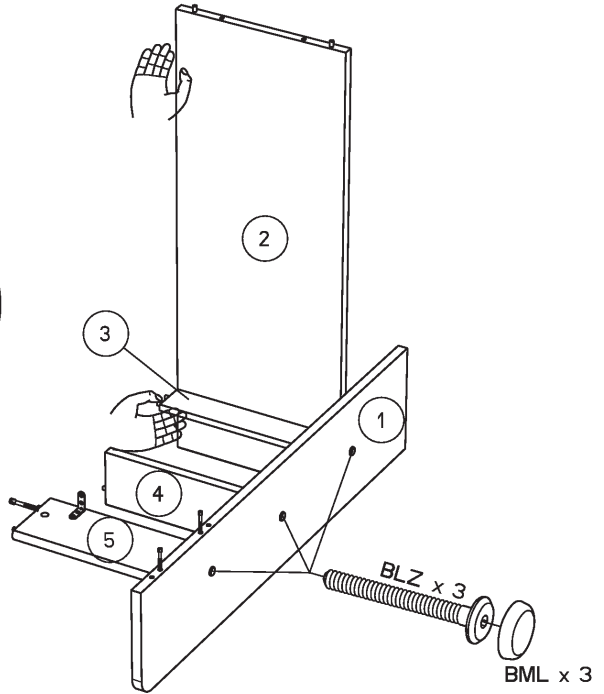
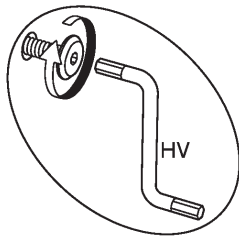

8

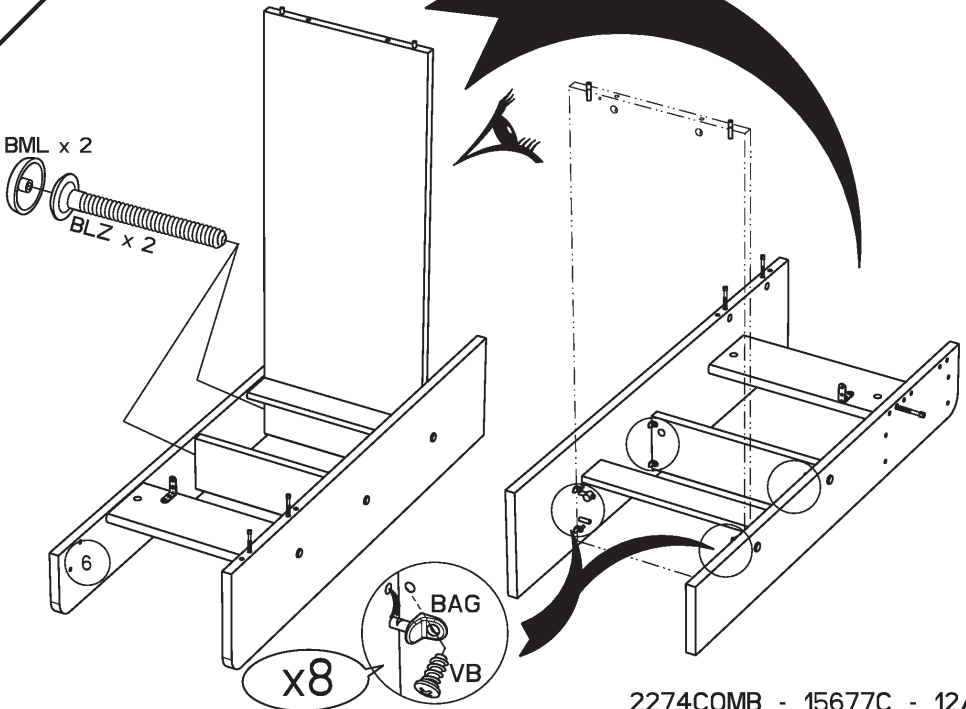
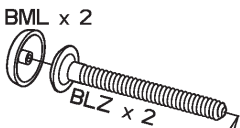

9

BLZ x 2

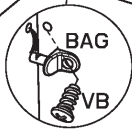

7

10

AHX

Vi x 4

AP x 2

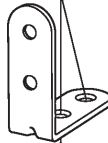

LN x 2

AHX x 2

8

AP x 2



11

AP

+



9

+

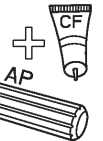

AP x 2

+

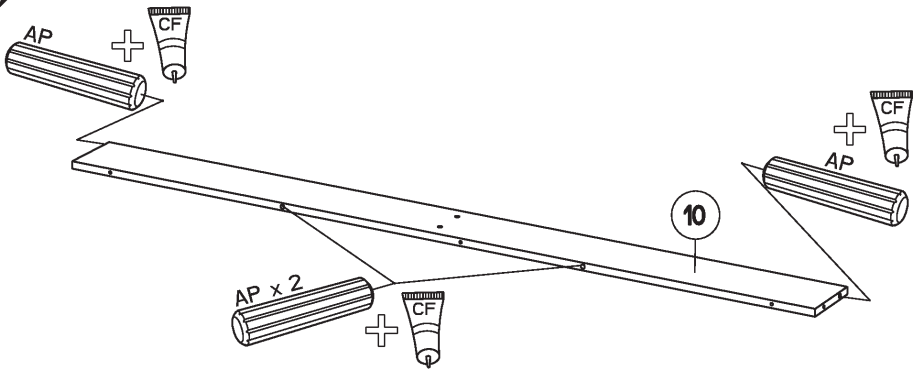
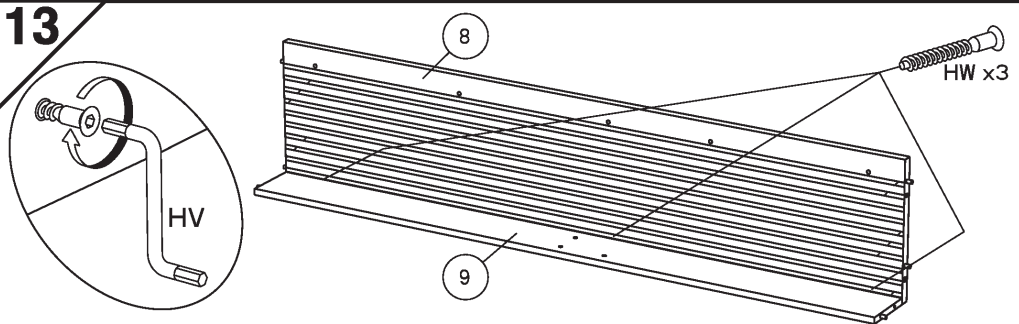
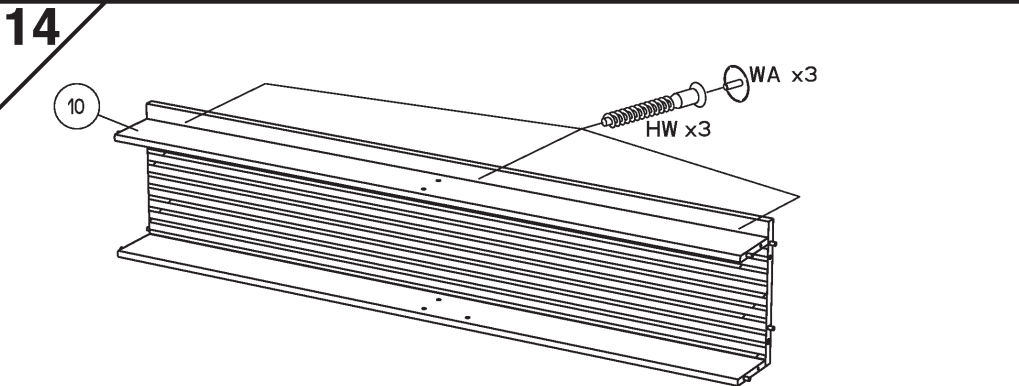
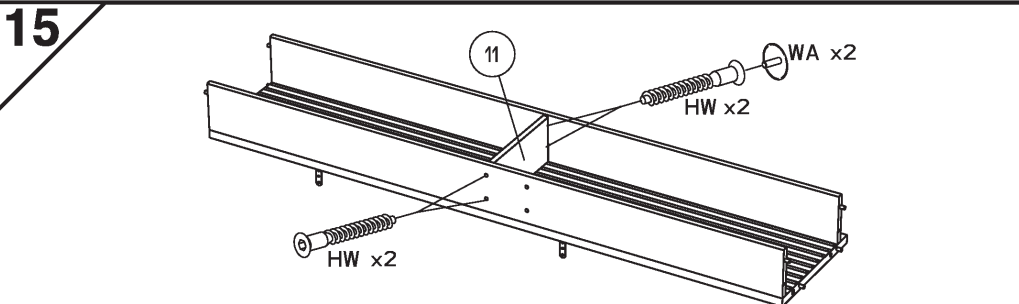

12**13****14****15**

16

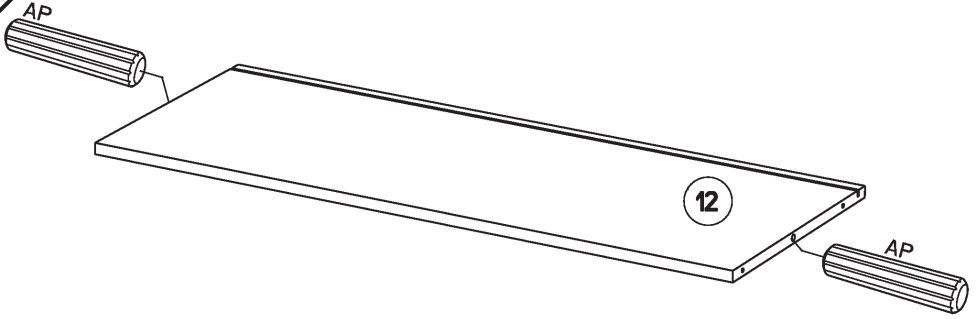

17

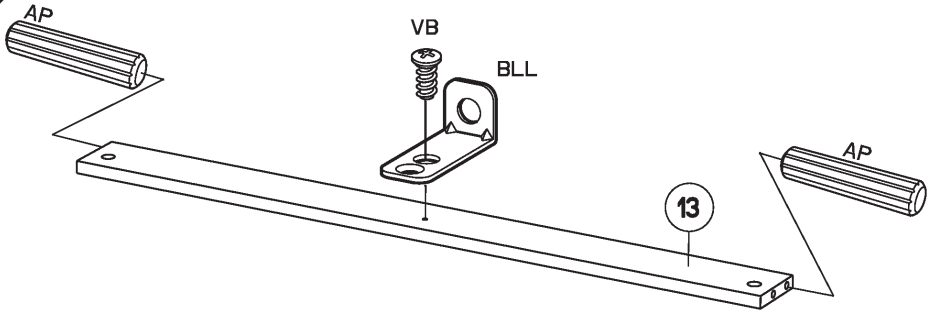

18

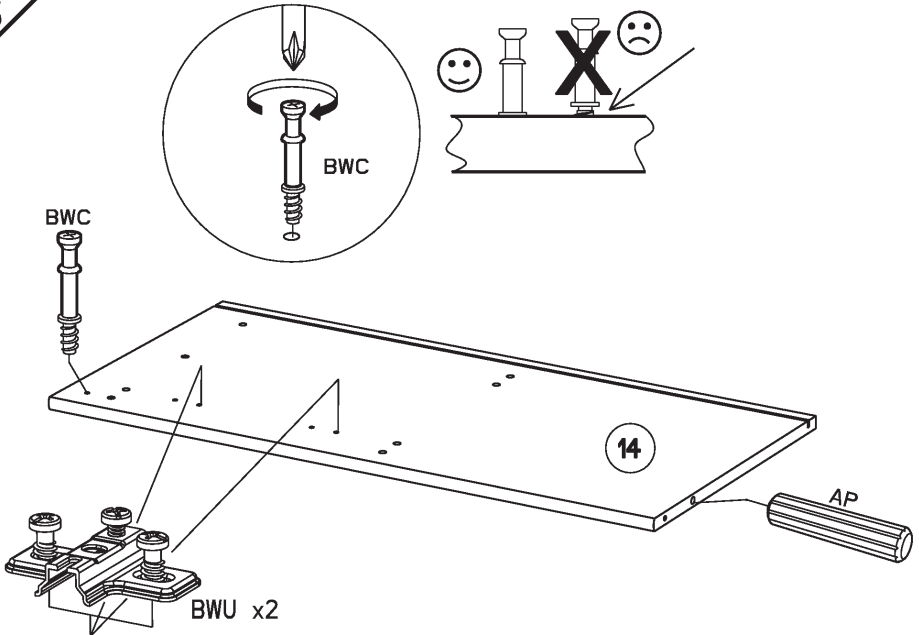

19

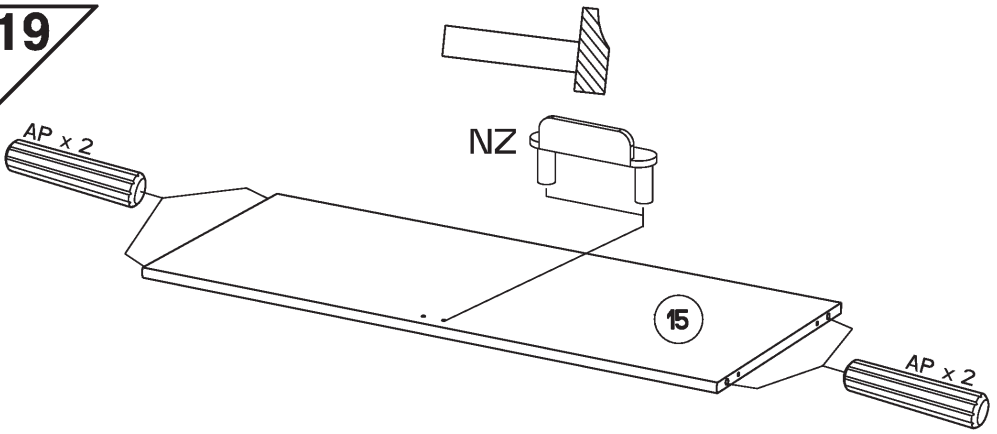

20

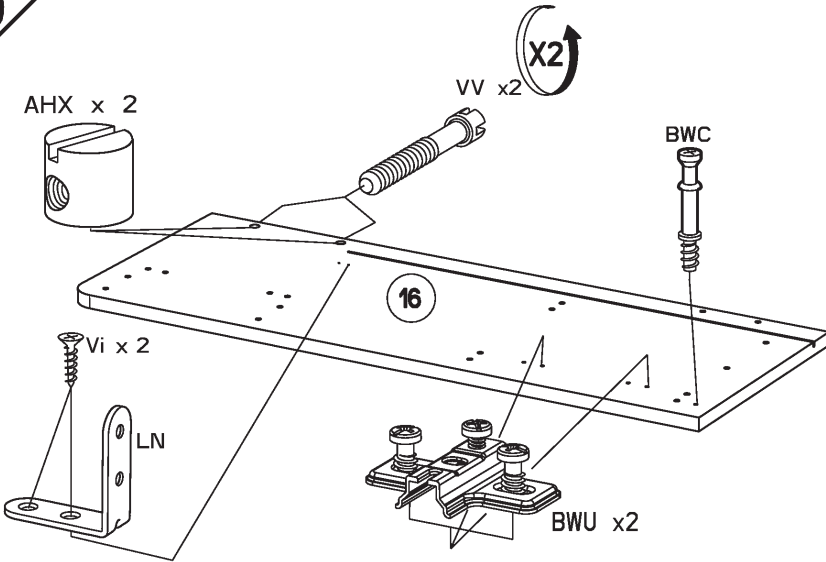

21

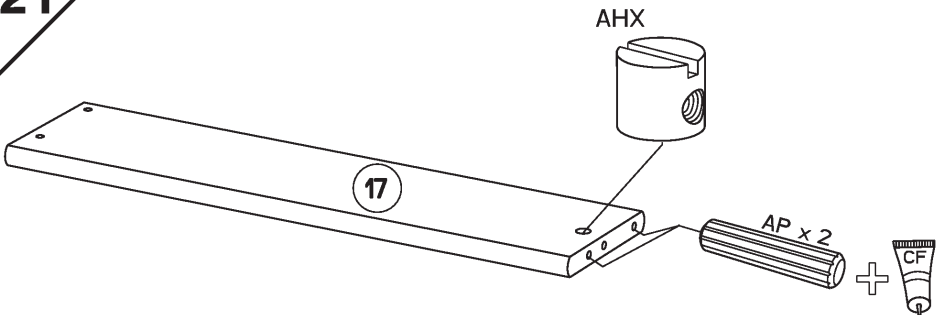

22

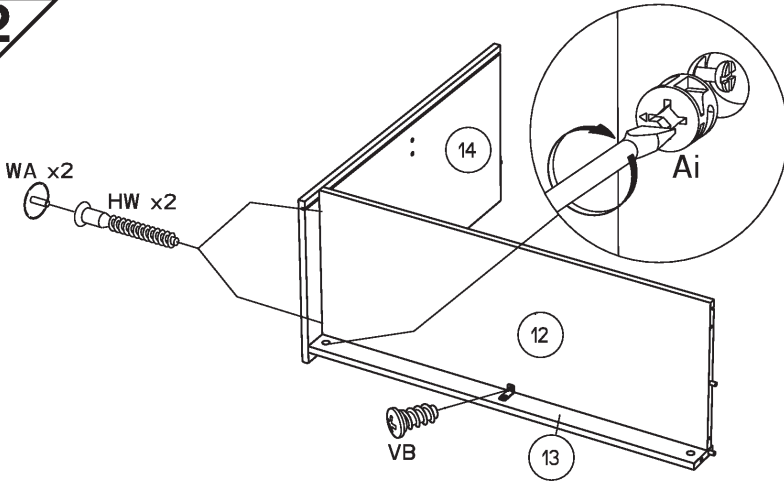

23

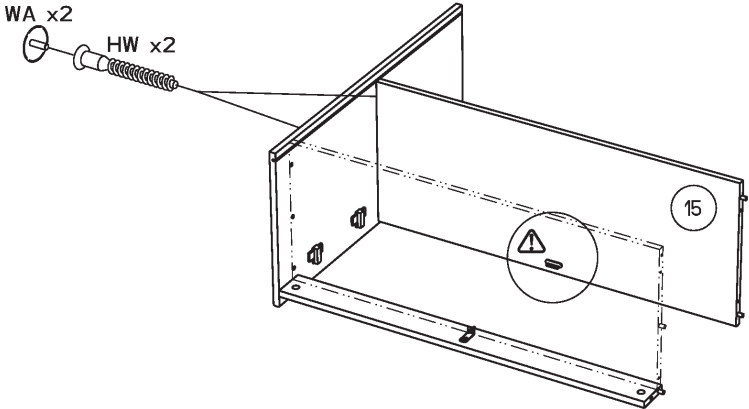

24

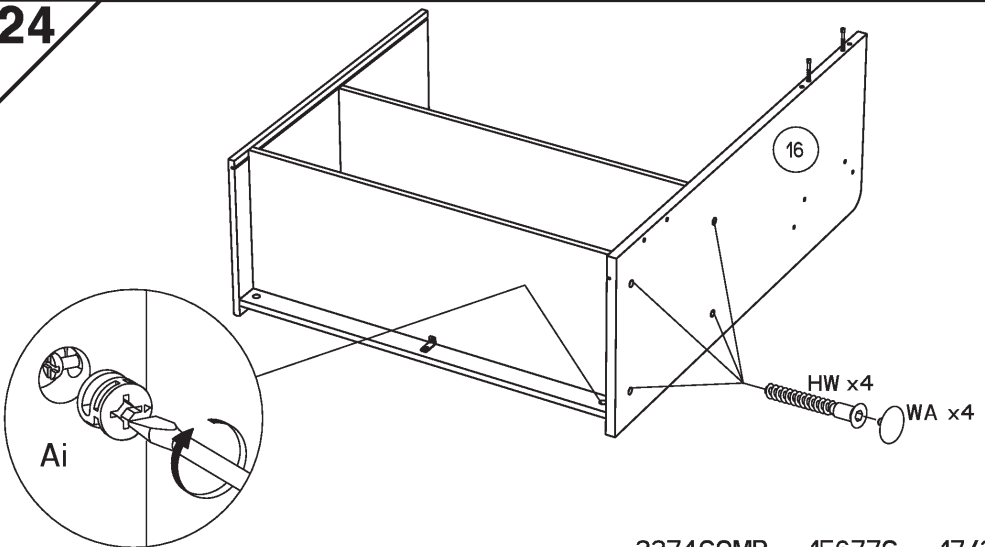

25

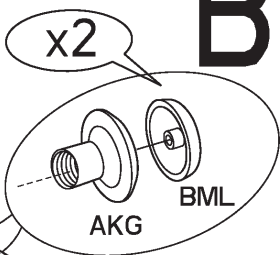
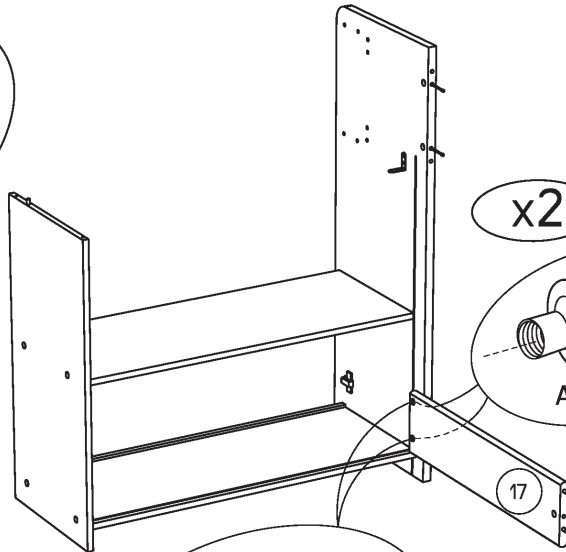
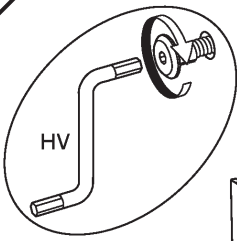

A

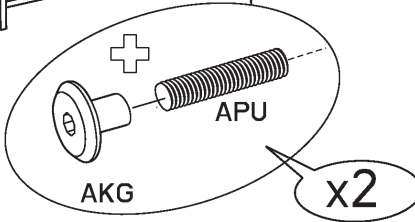

26

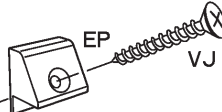
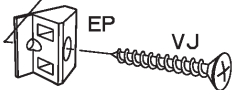
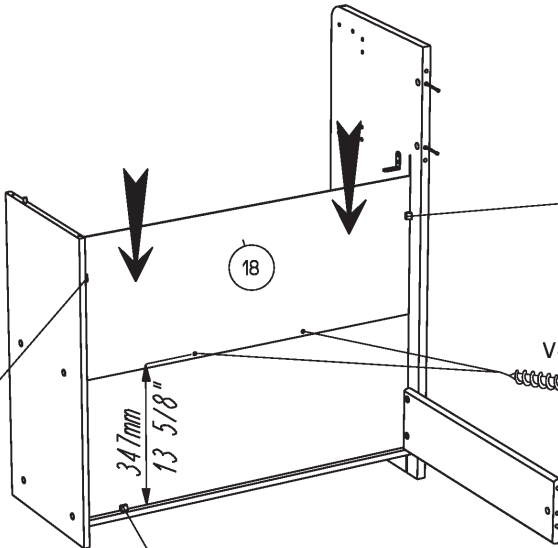

27

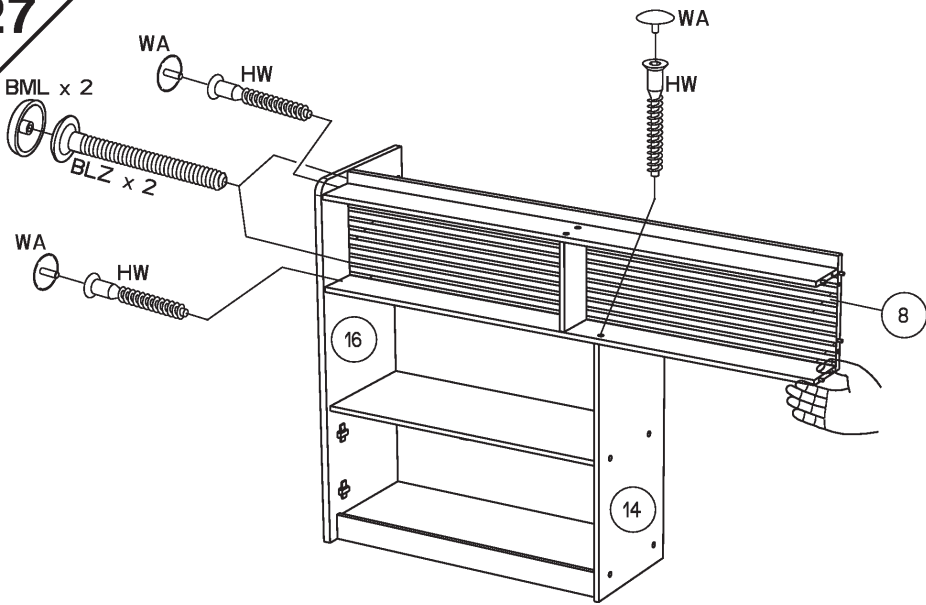

28

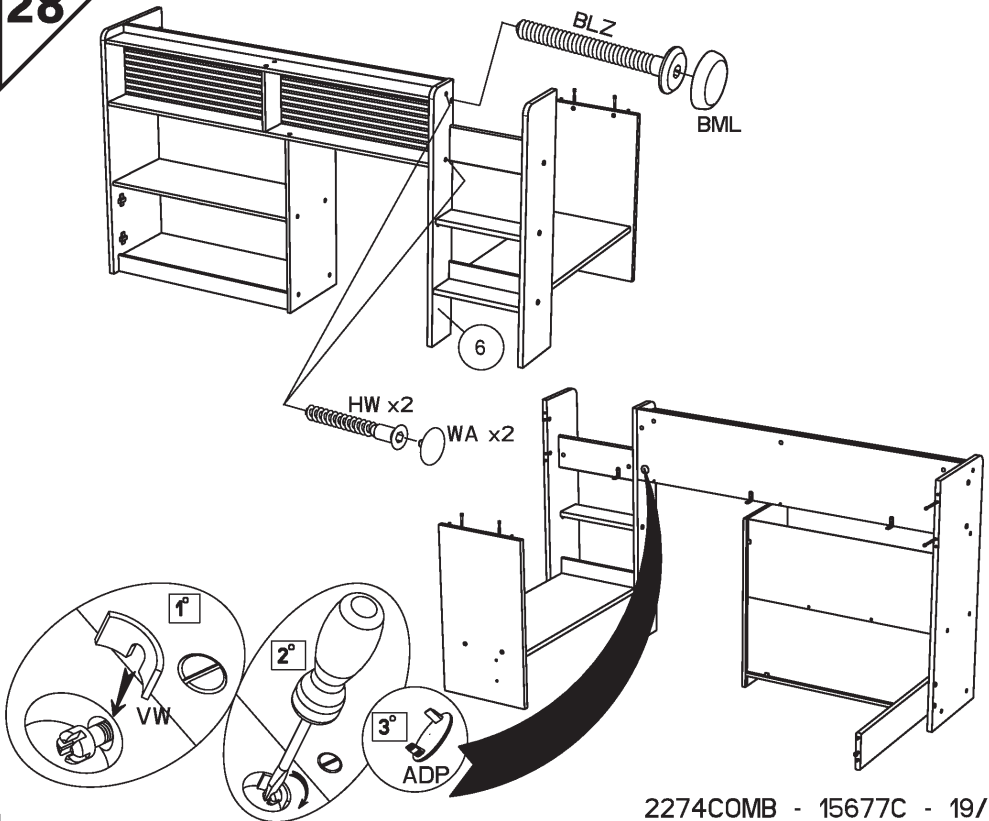

29

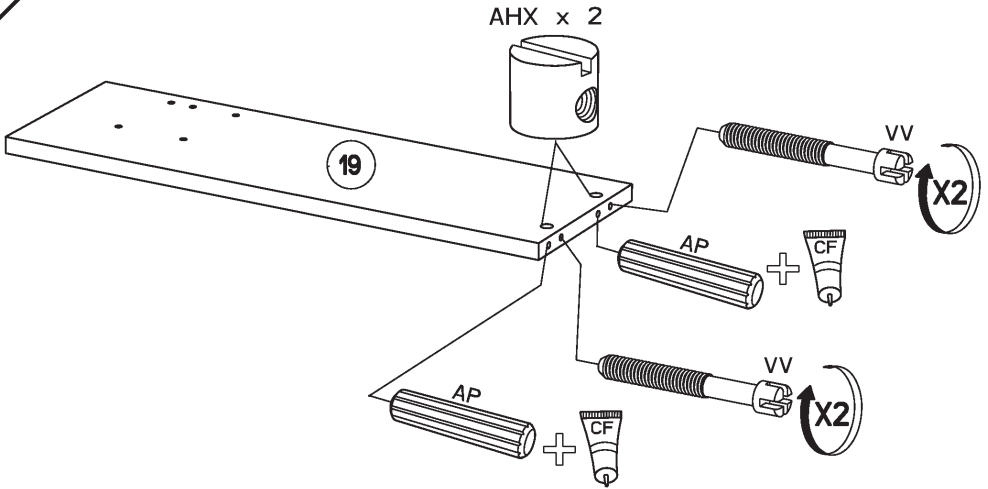

30

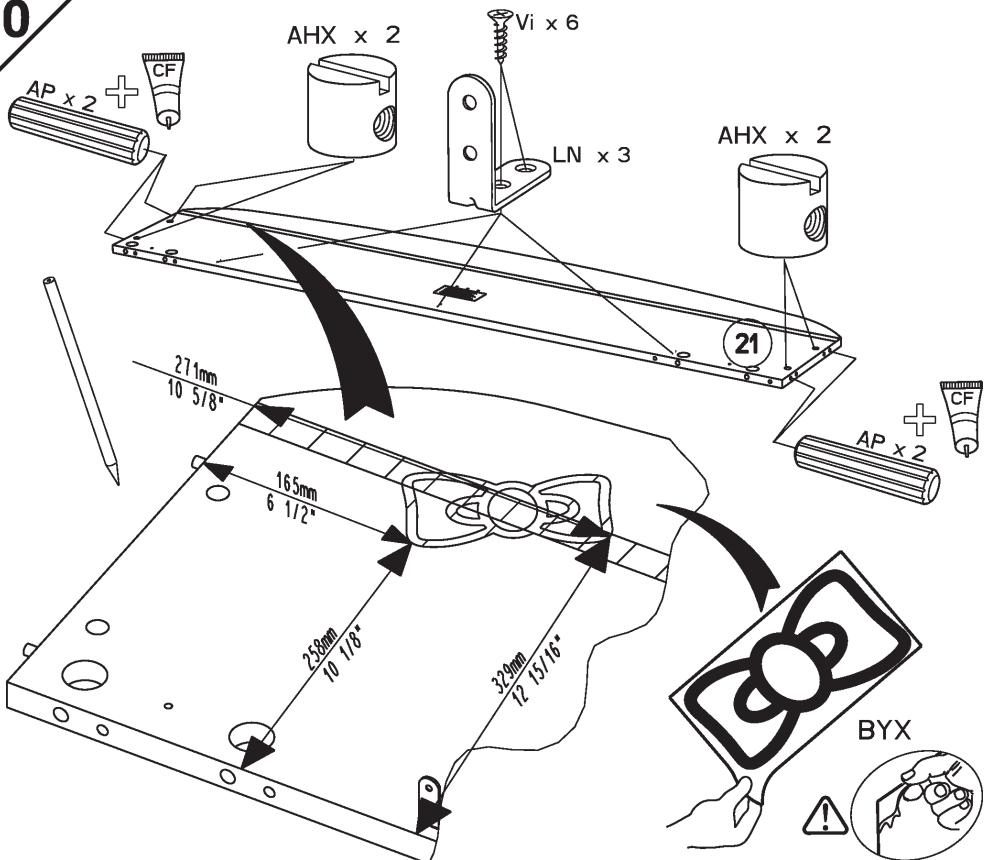

31

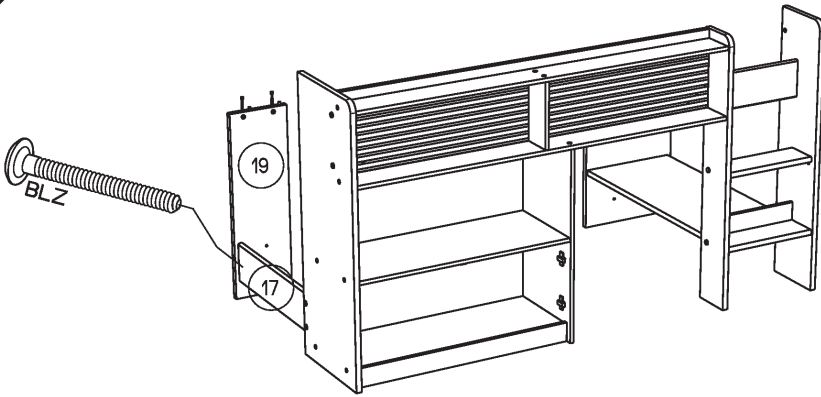

32

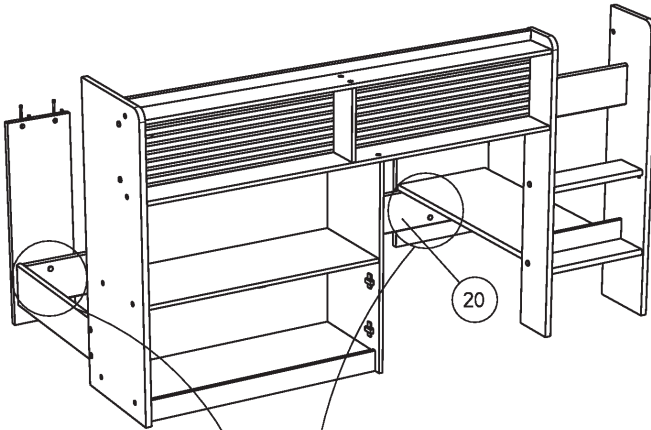

A

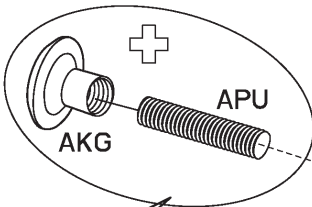

x4

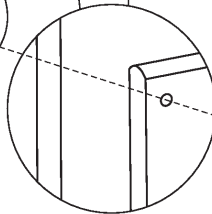

B

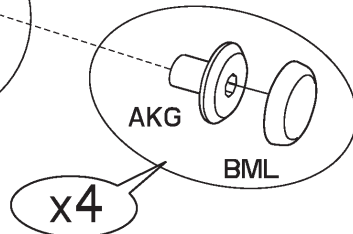

x4

33

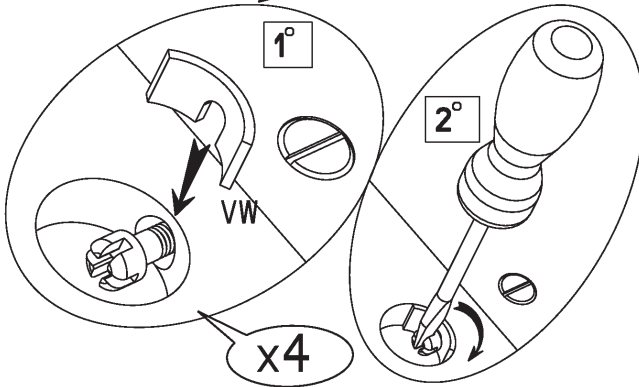
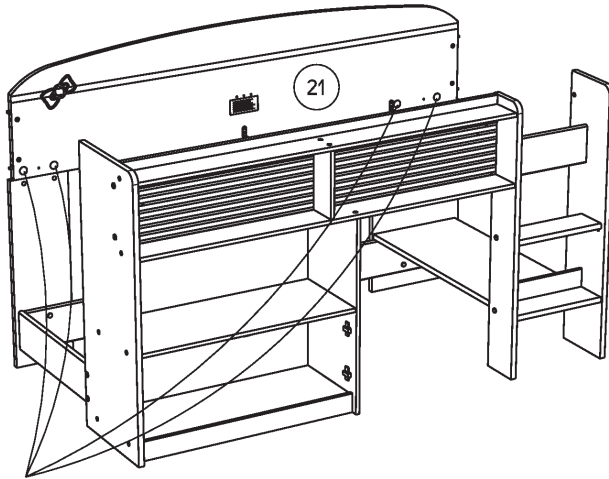

34

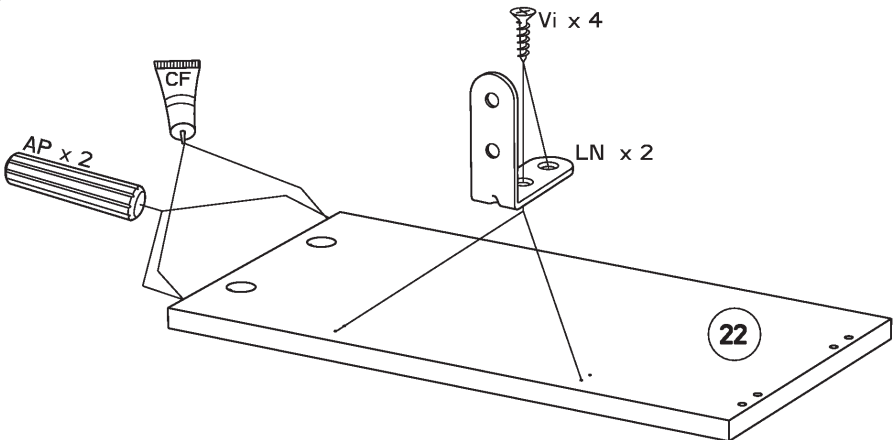

35

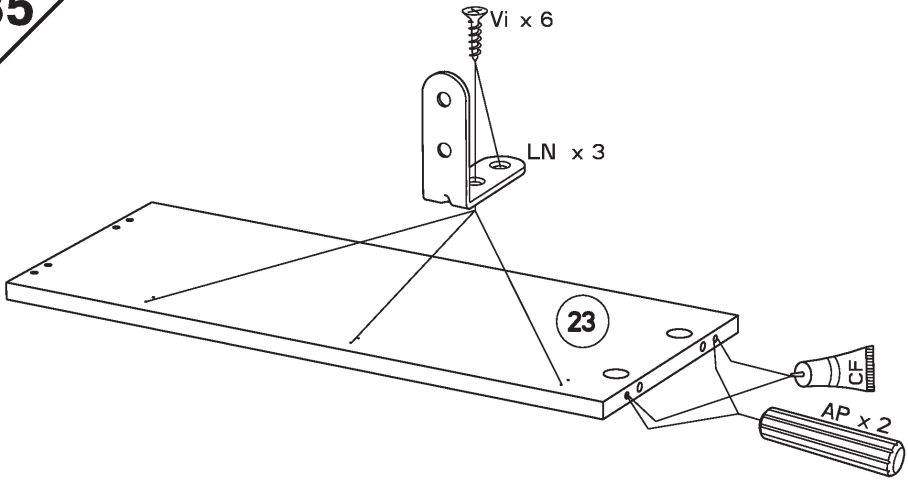

36

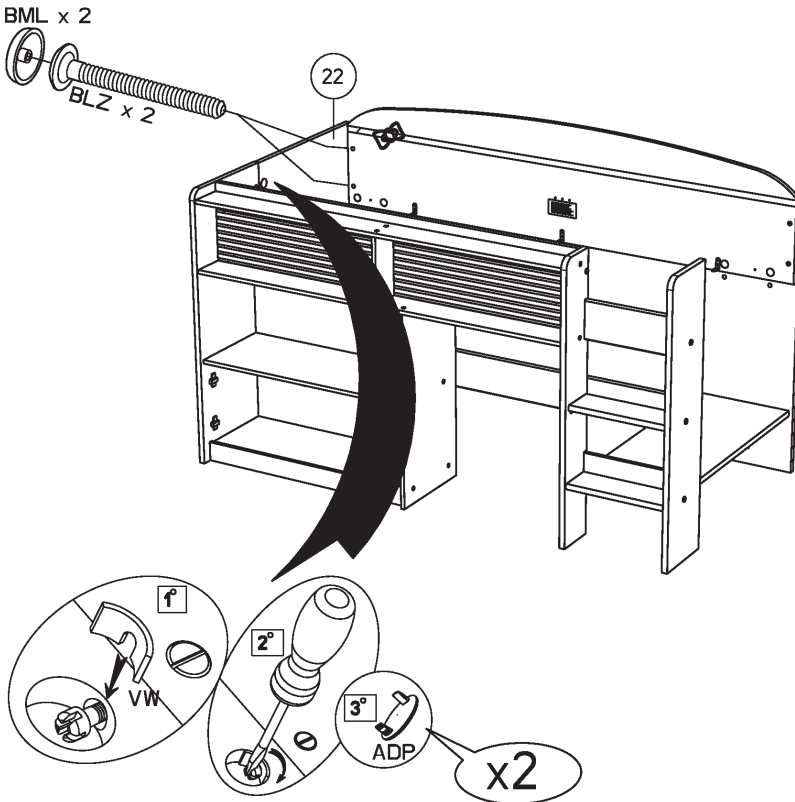

37

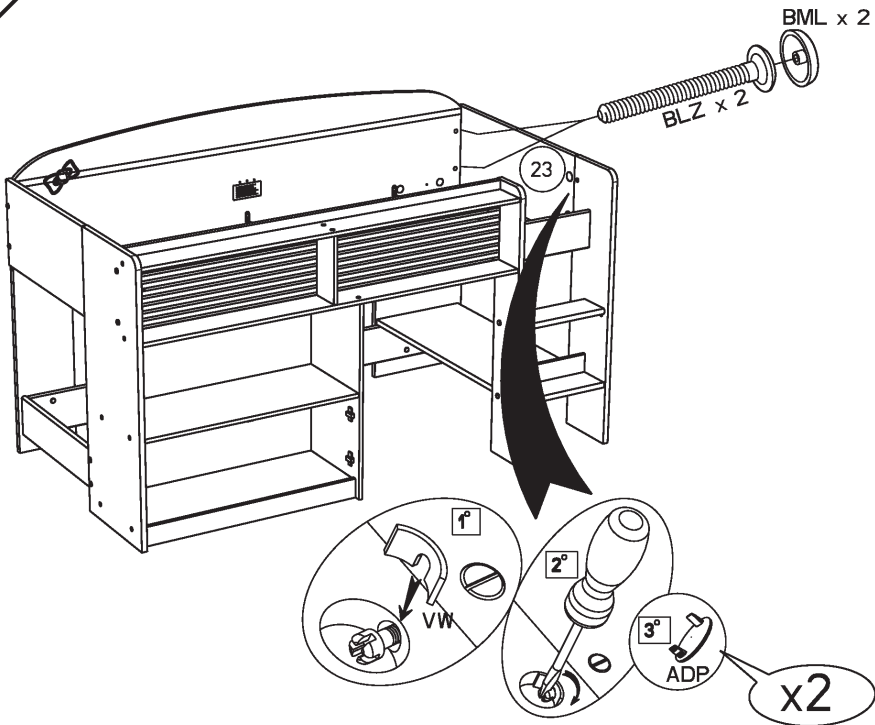

38

FR

Pour votre sécurité : Fixation du meuble au mur

Attention, la fixation doit être réalisée par une personne compétente car cela nécessite des chevilles adaptées à la nature de votre mur.

GB

For your own safety: attach the furniture to the wall

Important! The furniture must be attached by a qualified person using dowels that are suited to the type of wall.

D

Für Ihre Sicherheit: Befestigung des Möbelstücks an der Wand

Achtung, die Befestigung muss von einem Fachmann vorgenommen werden, weil sie an die Wand angepasste Dübel erfordert.

E

Para su seguridad: Fijación del mueble a la pared

¡Ojo! La fijación deberá llevarla a cabo una persona competente ya que necesitará unos tacos adaptados a tipo de pared.

PT

Para a sua segurança: Fixação do móvel na parede

Atenção, a fixação deve ser efectuada por uma pessoa competente, pois exige a utilização de cavilhas adaptadas à natureza da parede.

I

Per la vostra sicurezza: fissaggio del mobile alla parete.

Nota bene, il fissaggio deve essere eseguito da personale specializzato, poiché l'utilizzo di tasselli adattati alla parete.

NL

Voor uw veiligheid: bevestiging van het meubel aan de muur.

Let op, de bevestiging moet worden uitgevoerd door een bevoegd persoon, want hiervoor zijn pluggen nodig die specifiek geschikt zijn voor de betreffende muur.

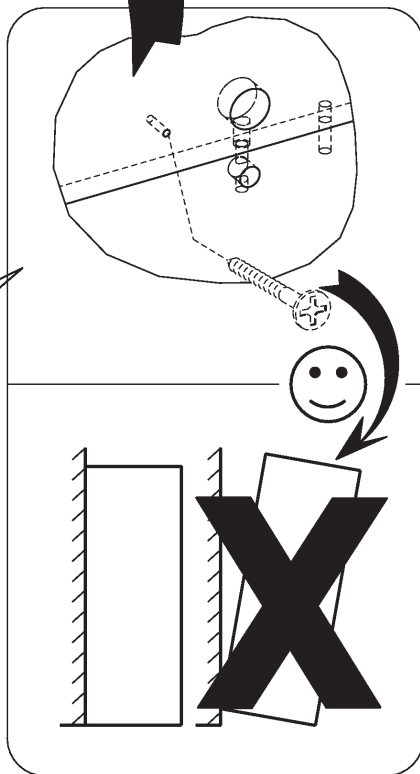
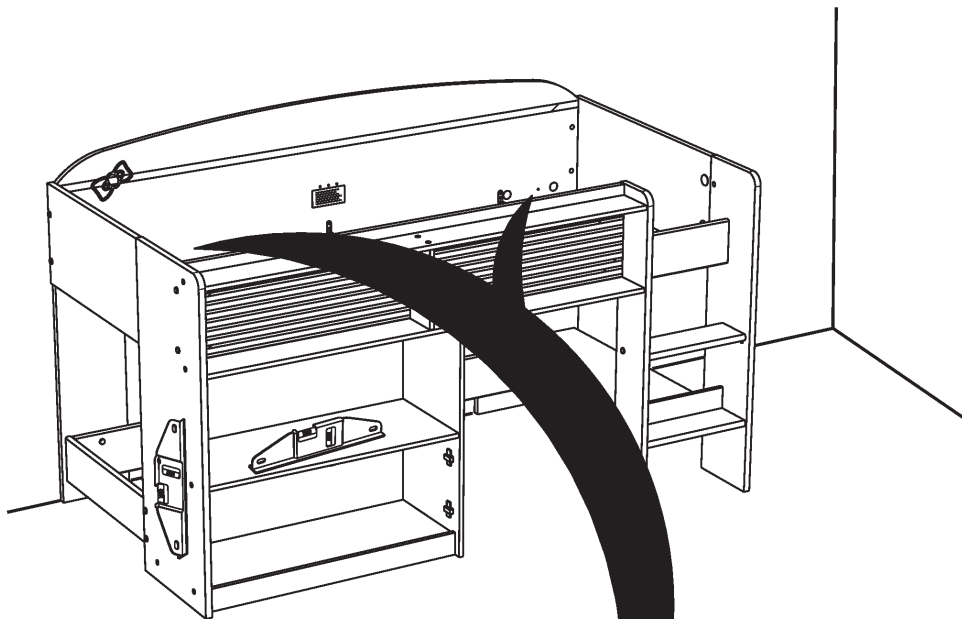

x2

39

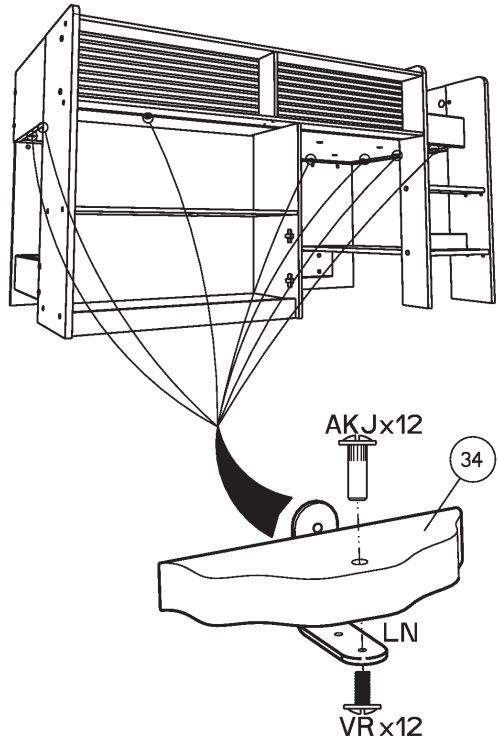
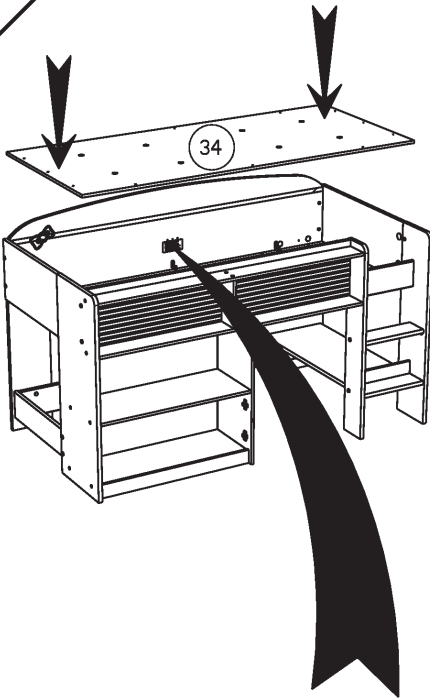

**LA FACE SUPERIEURE DU MATELAS
NE DOIT PAS SE TROUVER AU DESSUS
DE LA MARQUE FAITE SUR LE LIT**

- (GB) THE TOP SIDE OF THE MATTRESS
MUST NOT BE ABOVE THE MARK
INDICATED ON THE BED
- (D) DIE OBERSEITE DER MATRATZE DARF
SICH NICHT UBER DER AUF DEM BETT
ANGEGEBENEN MARKIERUNG BEFINDEN
- (E) LA CARA SUPERIOR DEL COLCHON
DEBE ESTAR ENCIMA DE LA MARCA
HECHA EN LA CAMA
- (P) A PARTE SUPERIOR DO COLCHAO
NAO DEVE ESTAR EM CIMA
DA MARCA FEITA NA CAMA
- (I) LA FACCIA SUPERIORE DEL MATERASSO
NON DEVE ESSERE AL DISOPRA
DEL MARCHIO FATTO SUL LETTO
- (NL) DE BOUENKANT VAN DE MATRAS
MAG MET MERRTEREN OP HET
BED NIET OVERSCHRYDEN

40

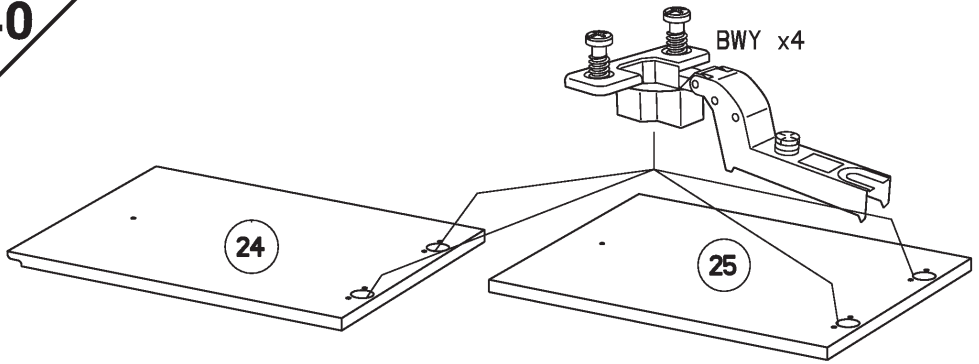

41

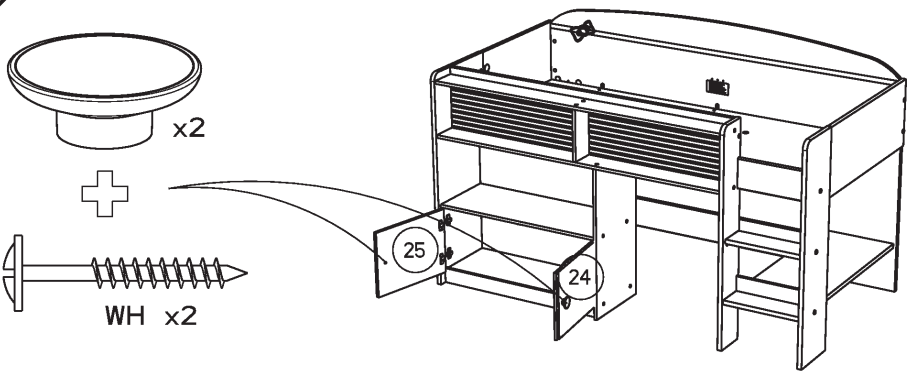

RCH-N

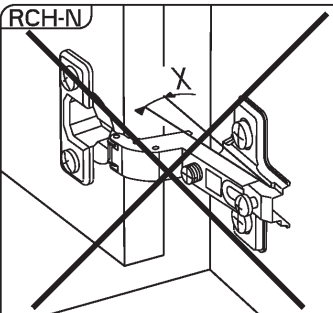

MONTAGE

- (GB) LEAFLET
- (D) AUFBAUANLEITUNG
- (E) MONTAJE
- (P) MONTAGEM
- (I) MONTAGGIO
- (NL) MONTAGE

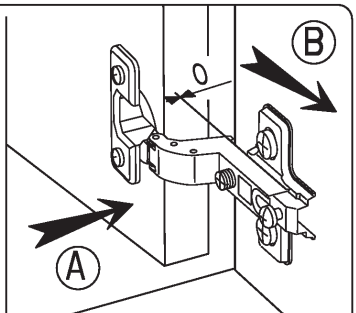

REGLAGE

- (GB) ADJUSTING
- (D) ANPASSUNG
- (E) AJUSTER
- (P) REGULACAO
- (I) AGGIUSTAMENTO
- (NL) AFSTELLING

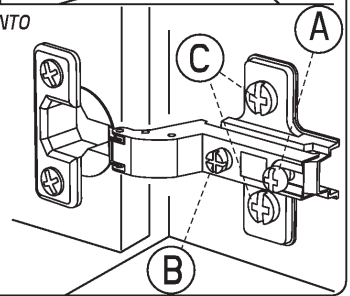
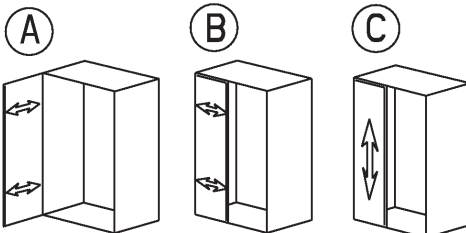

42

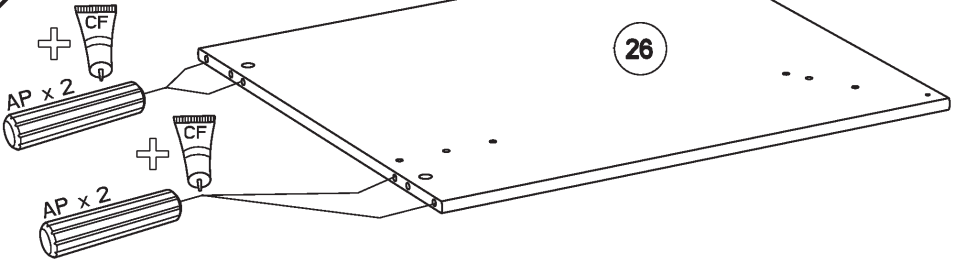

43

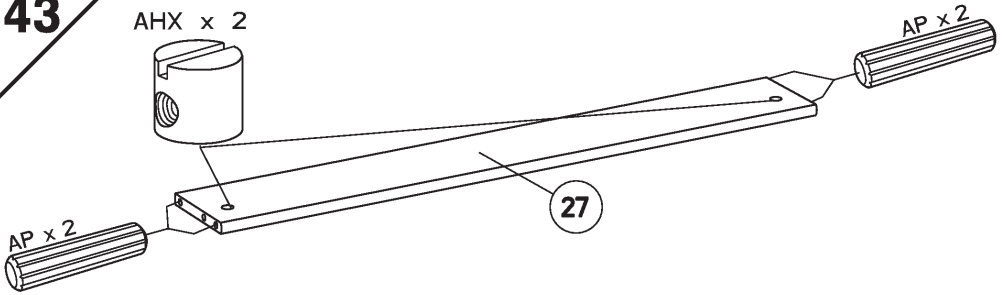

44

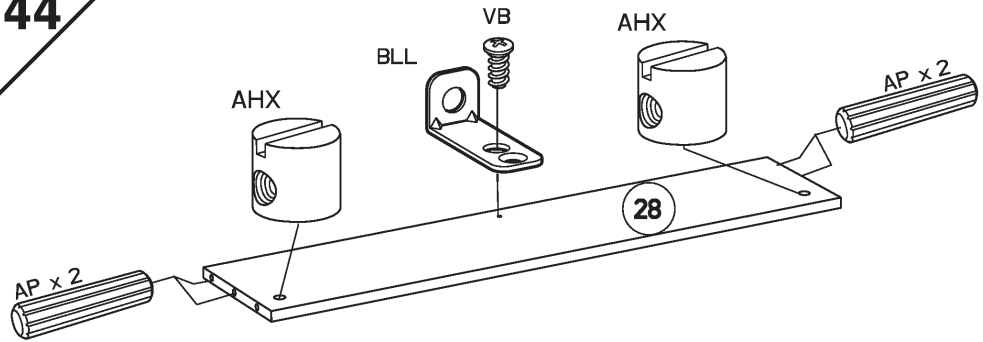

45

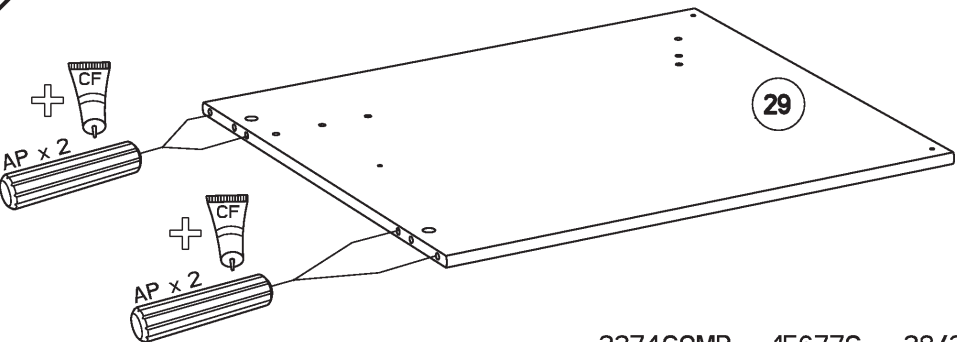

46

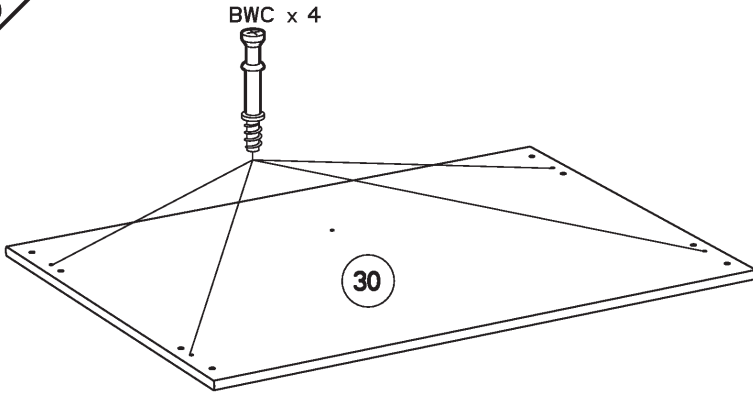

47

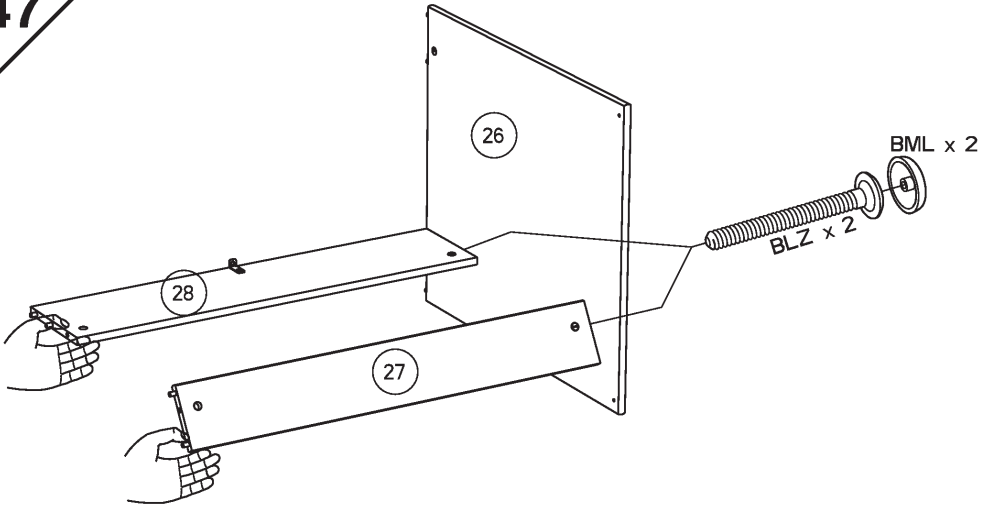

48

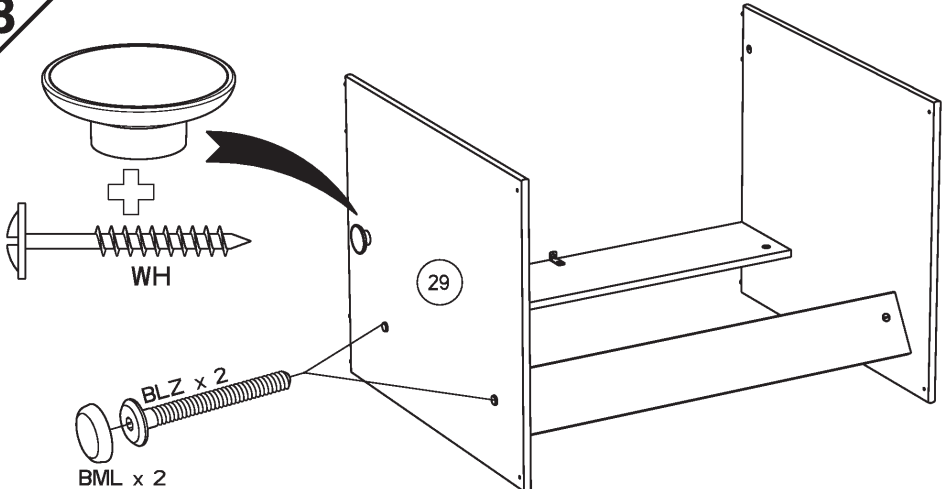

49

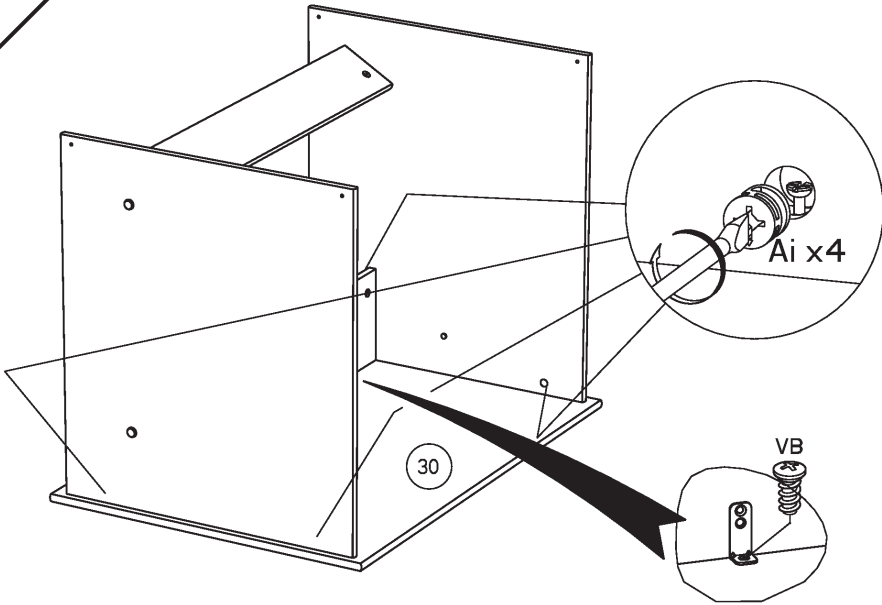

50

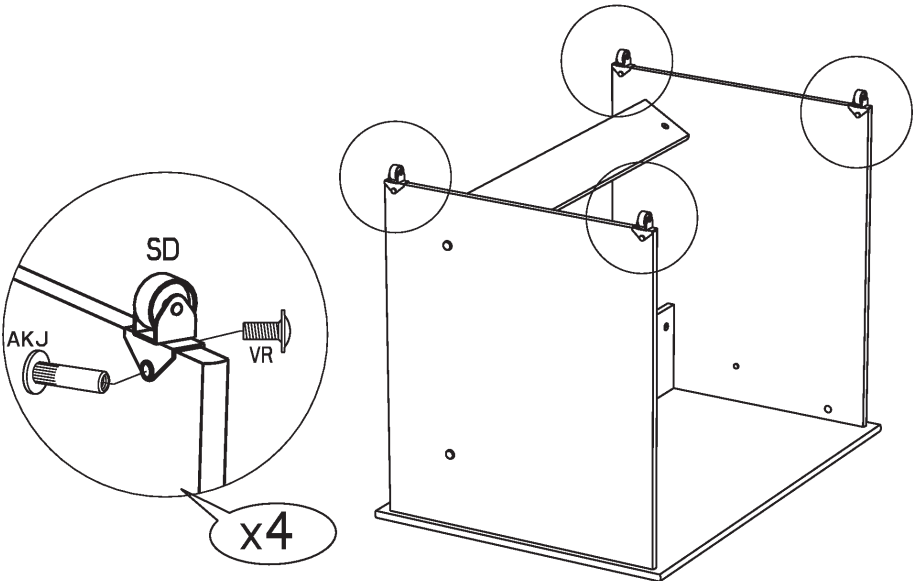

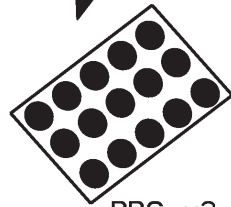
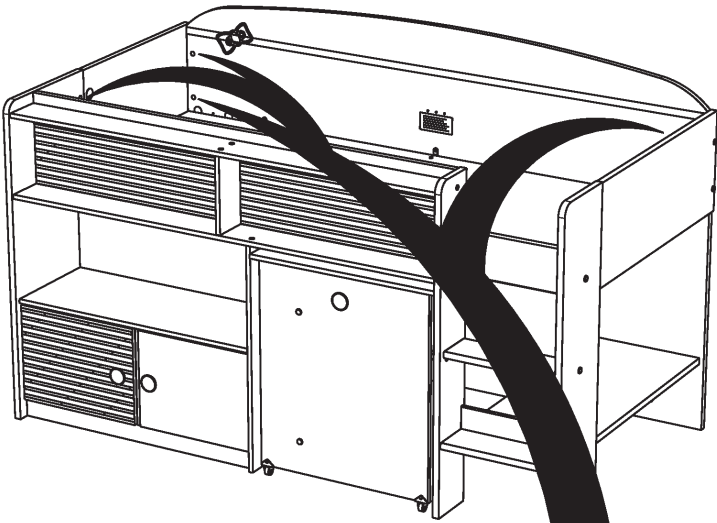

BRC x3

- (F) Attention pour votre sécurité, ne pas dépasser les charges maxi
- (GB) Take care not to exceed the maximum safety load
- (D) Zu Ihrer Sicherheit niemals die maximale Belastung überschreiten
- (E) Tenga cuidado por su seguridad y no exceda las cargas máximas.
- (P) Atenção, para a sua segurança, não exceder as cargas máximas.
- (I) Per la vostra sicurezza non superare mai il carico massimo consentito.
- (NL) Voor uw veiligheid: nooit de maximale belasting overschrijden.

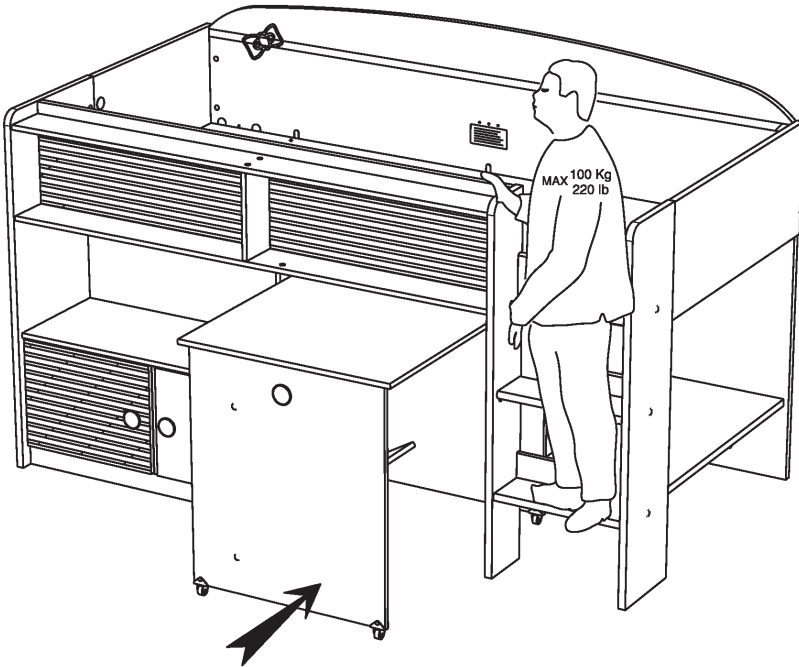

PARISOT MEUBLES
70800 SAINT LOUP SUR SEMOUSE (FRANCE)

- (F) CONFORME AUX EXIGENCES DE SECURITE
- (GB) COMPLY WITH THE SECURITY STANDARDS
- (D) GEMAB DEN SICHERHEITSNORMEN
- (E) CONFORME A LAS EXIGENCIAS DE SEGURIDAD
- (P) EM CONFORMIDADE COM AS EXIGENCIAS DE SEGURANCA
- (I) CONFORME ALLE ESIGENZE DI SICUREZZA
- (NL) CONFORM DE VEILIGHEIDSVEREISTEN

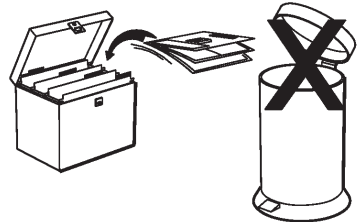

Faites un geste pour l'environnement en triant vos déchets d'emballage
Make a gesture for the environment by sorting out your waste of packaging
Machen Sie eine Bewegung für die Umwelt, ihre Verpackungsabfälle sortierend
Haga un gesto para el medio ambiente escogiendo sus residuos de embalaje