

SAV
SPAREPARTS
KUNDEDIENST
POST VENTAS
SERVICE NA VERKOOP
SERVIZIO POST-VENDITA
SERVICO DEPOIS DE VENDA
SERWIS POGWARANCYJNY

1888 1

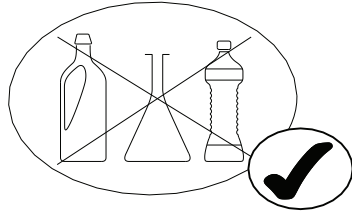

FR MEUBLES A FIXER AU MUR:
- FIXER LE MEUBLE AU MUR AVEC LES ATTACHES PREVUES A CET EFFET
- VERIFIER QUE LES VIS ET LES CHEVILLES UTILISEES SONT ADAPTEES AU SUPPORT

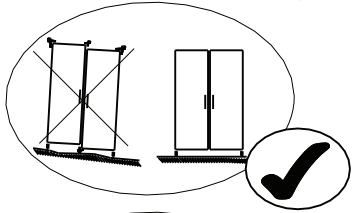

ES MUEBLES A FIJAR EN LA PARED:
- FIJAR EL MUEBLE EN LA PARED CON LAS GRAPAS PREVISTAS
- COMPROBAR QUE LOS TORNILLOS Y LAS CLAVIJAS UTILIZADAS SON ADAPTADAS AL SOPORTE

PT MOVEIS A FIXAR NA PAREDE:
- FIXAR O MOVEL NA PAREDE COM OS PRENDOS PREVISTOS
- VERIFICAR QUE OS PARAFUSOS E AS CAVILHAS UTILIZADOS SAO ADAPTADOS AO SUPORTE

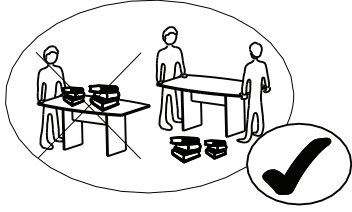

EN FURNITURES TO BE HOLD ON THE WALL:
- HOLD THE FURNITURE ON THE WALL WITH THE FASTENINGS PROVIDED FOR THIS PURPOSE
- CHECK THAT THE SCREW AND PEGS FIT WITH THE SUPPORT

IT MOBILI DA FISSARE AL MURO:
- FISSARE IL MOBILE AL MURO CON LE FLANGIE PREVISTE A TALE SCOPO
- VERIFICARE CHE LE VITI ED I PERNI USATI SIANO ADATTI A QUEL TIPO DI SUPPORTO

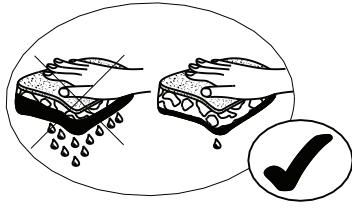

PL MEBEL PRZEZNACZONY DO ZAINSTALOWANIA NA SCIANIE:
- NALEŻY ZAMONTOWAĆ TEN MEBEL NA SCIANIE PRZEZNACZONYMI DO TEGO CELU UCHWYTAMI
- NALEŻY SPRAWDZIĆ CZY SRUBY I KOSZULKI SA, ODPOWIEDNIEJ WIELKOŚCI W STOSUNKU DO UCHWYTÓW

DE MOEBEL AN DER MAUER ZU BEFESTIGEN:
- BEFESTIGEN SIE DAS MOEBELSTUECK MIT DEN DAFUER VORGEGEHENEN BEFESTIGUNGSHAKEN
- UEBERPRUEFEN SIE BITTE DASS DIE SCHRAUBEN UND DUEBEL MIT DEM MATERIAL DER MAUER UEBEREINSTIMMEN

NL MEUBELS DIE AAN DE MUUR GEFIXEERD MOETEN WORDEN:
- FIXEER HET MEUBEL AAN DE MUUR MET DE DAARVOOR BESTEMDE HAKEN
- VERFIEER OF DE GEBRUIKTE SCHROEVEN BIJ DE BEVESTIGINGSHAAK HOREN

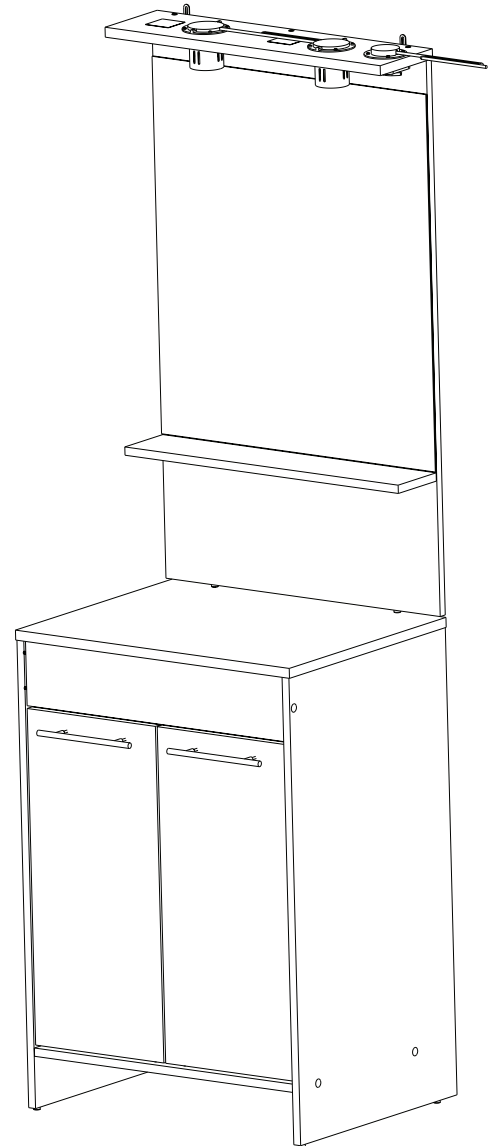

2H 00M N

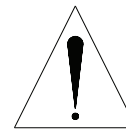
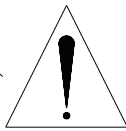

FR SECURITE
RESPECTER LES INSTRUCTIONS DE MONTAGE DECRITES DANS LA NOTICE.

EN CAUTION
FOLLOW CAREFULLY THE ASSEMBLING INSTRUCTIONS DESCRIBED IN THE DIRECTIONS.

DE SICHERHEITSVORSCHRIFTEN
BEACHTEN SIE BITTE UNBEDINGT DIE ANGEGBENEN AUFBAUVORSCHRIFTEN.

ES SEGURIDAD
RESPECTAR LAS INSTRUCCIONES DE MONTAJE DESCRIBIDAS EN EL FOLLETO.

NL VEILIGHEID
DE IN DE GEBRUIKSAANWIJZING BESCHREVEN INSTRUCTIES RESPECTEREN.

IT SICUREZZA
RISPETTARE LE ISTRUZIONI DI MONTAGGIO DESCRITTE NEEL 'AVVERTENZA.



PT SEGURANCA
RESPEITAR AS INSTURACOS DE MONTAGEM DESCRVEDAS NA INSTRUCOES DE USO.

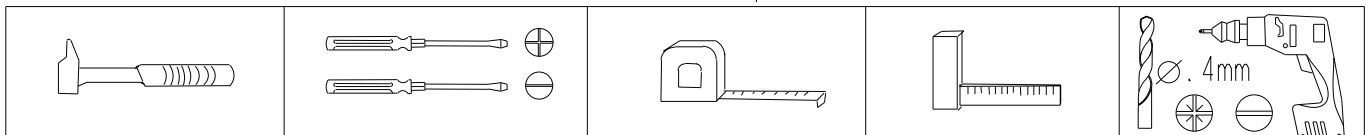

PL UWAGA
PROSZE, PRZESTRZEGAC INSTRUKCJI MONTAZU.

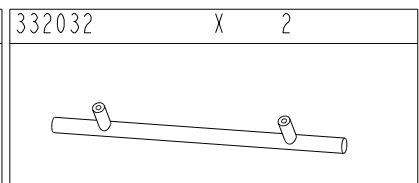
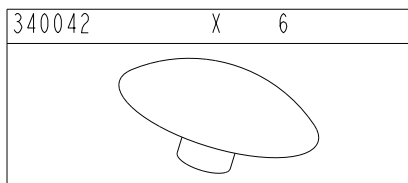
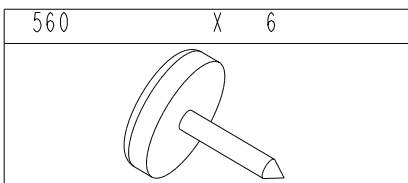
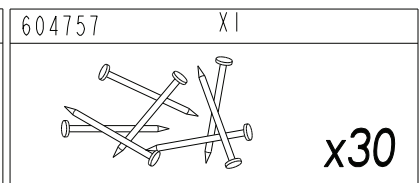
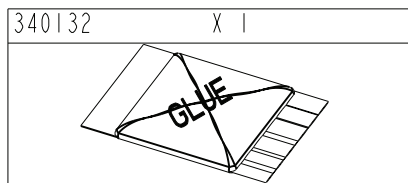
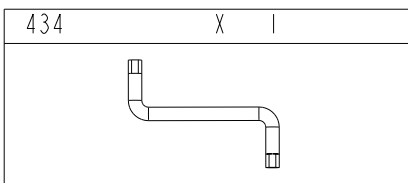
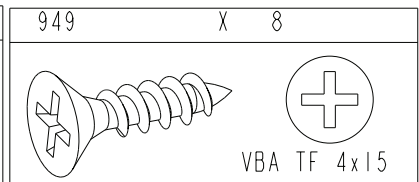
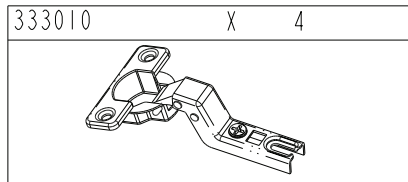
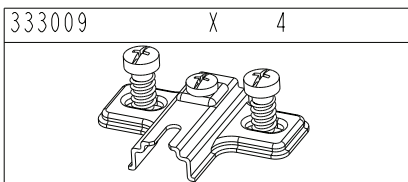
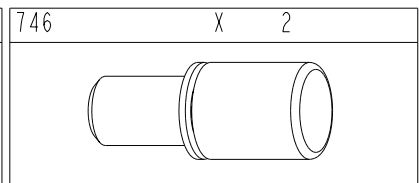
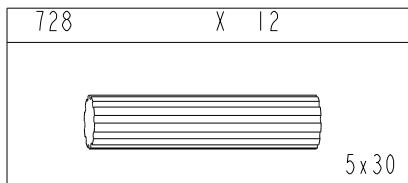
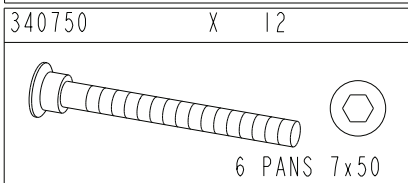
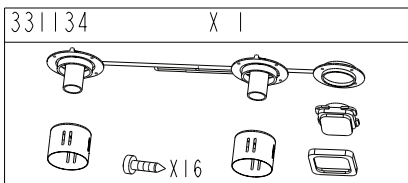
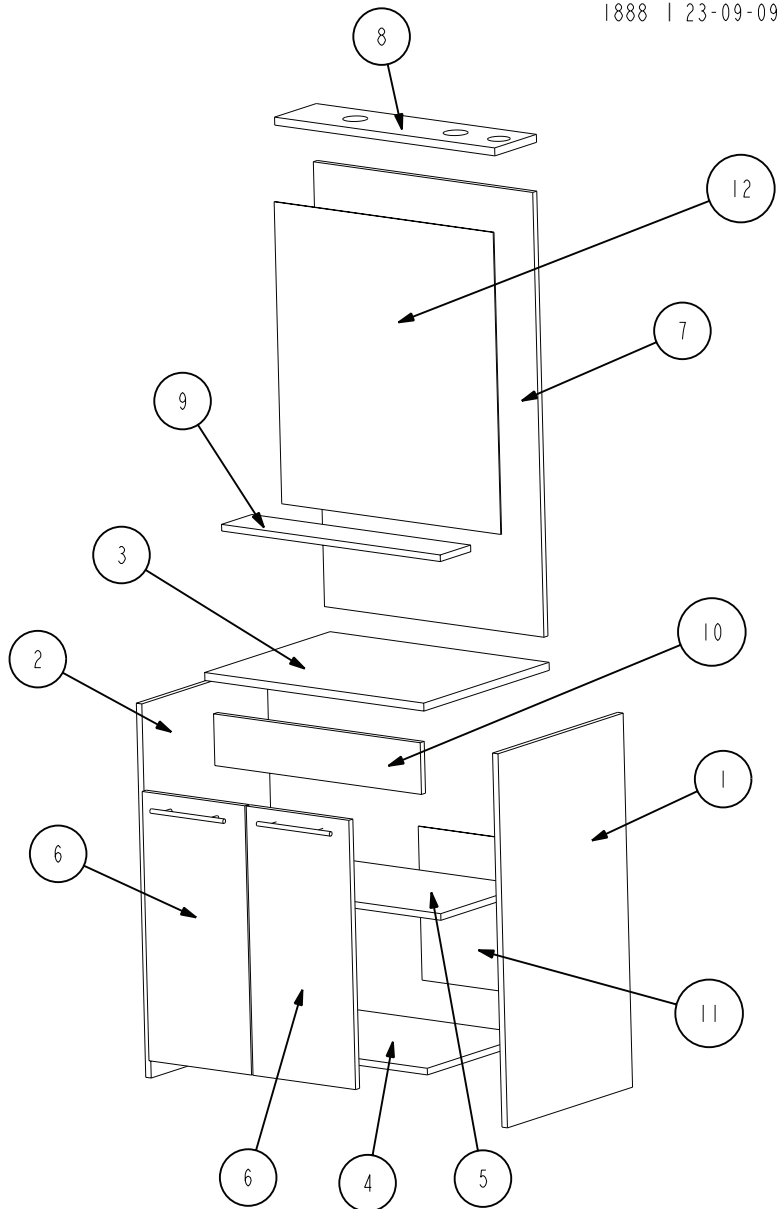

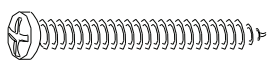

REP	DIM	QTE
1	846 x 465	1
2	846 x 465	1
3	600 x 466	1
4	566 x 389	1
5	566 x 325	1
6	609 x 281	2
7	1006 x 601	1
8	603 x 155	1
9	599 x 113	1
10	566 x 117	1
11	565 x 348	1
12	683 x 600	1

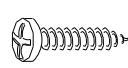



913	X 4
	
VBA TR 4x30	

906	X 4
	
VBA TR 3x12	

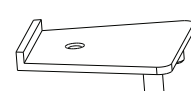
935	X 1
	
VBA SPAX TF 3x12	

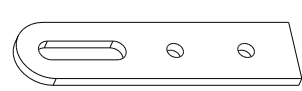
121	X 1
	

184	X 2
	

559	X 2
	

x 6

1

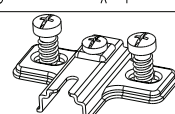
333009	X 4
	

728	X 4
	
5x30	

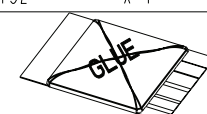
340132	X 1
	

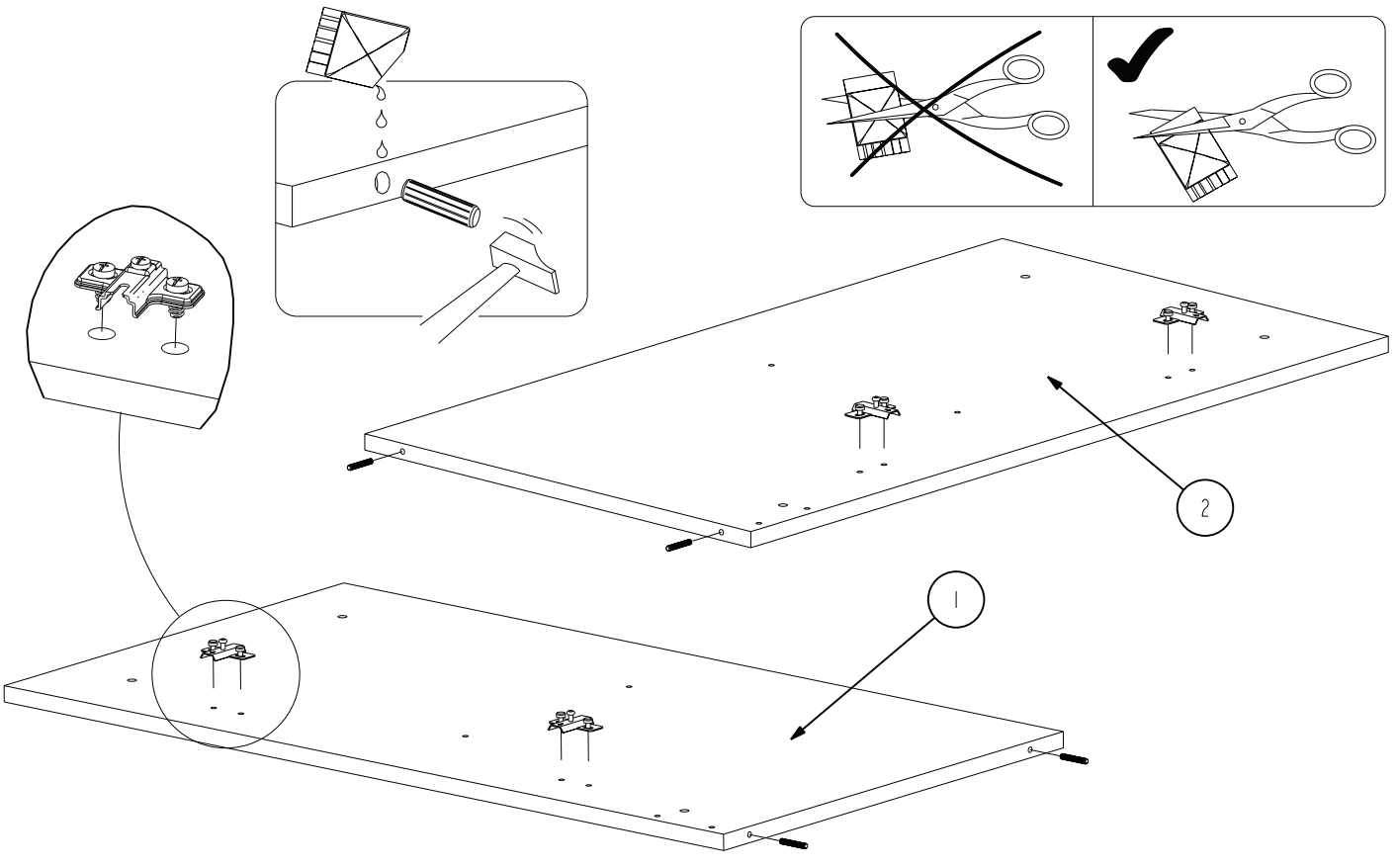
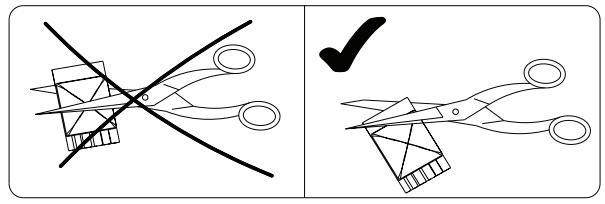

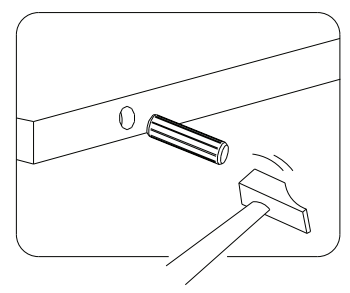
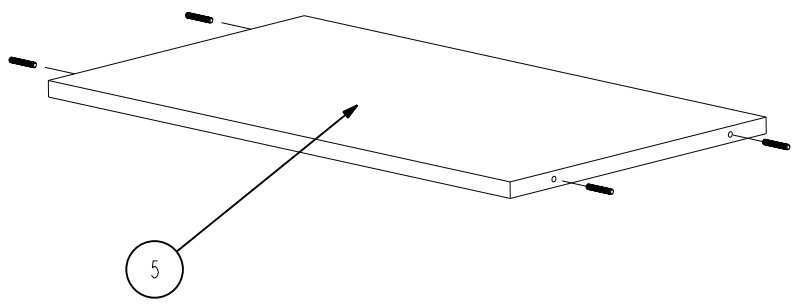

2

728	X 4
	
5x30	



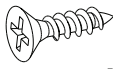

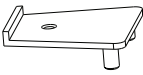
3

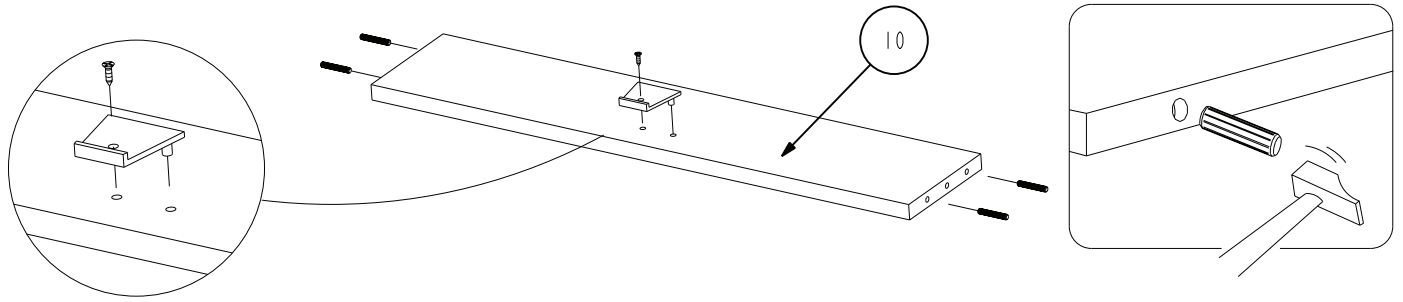
728	X 4	935	X 1	121	X 1
					
	5x30		VBA SPAX TF 3x12		

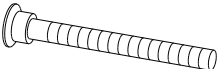

4

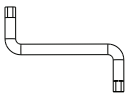
340750	X 6	434	X 1
			
	6 PANS 7x50		

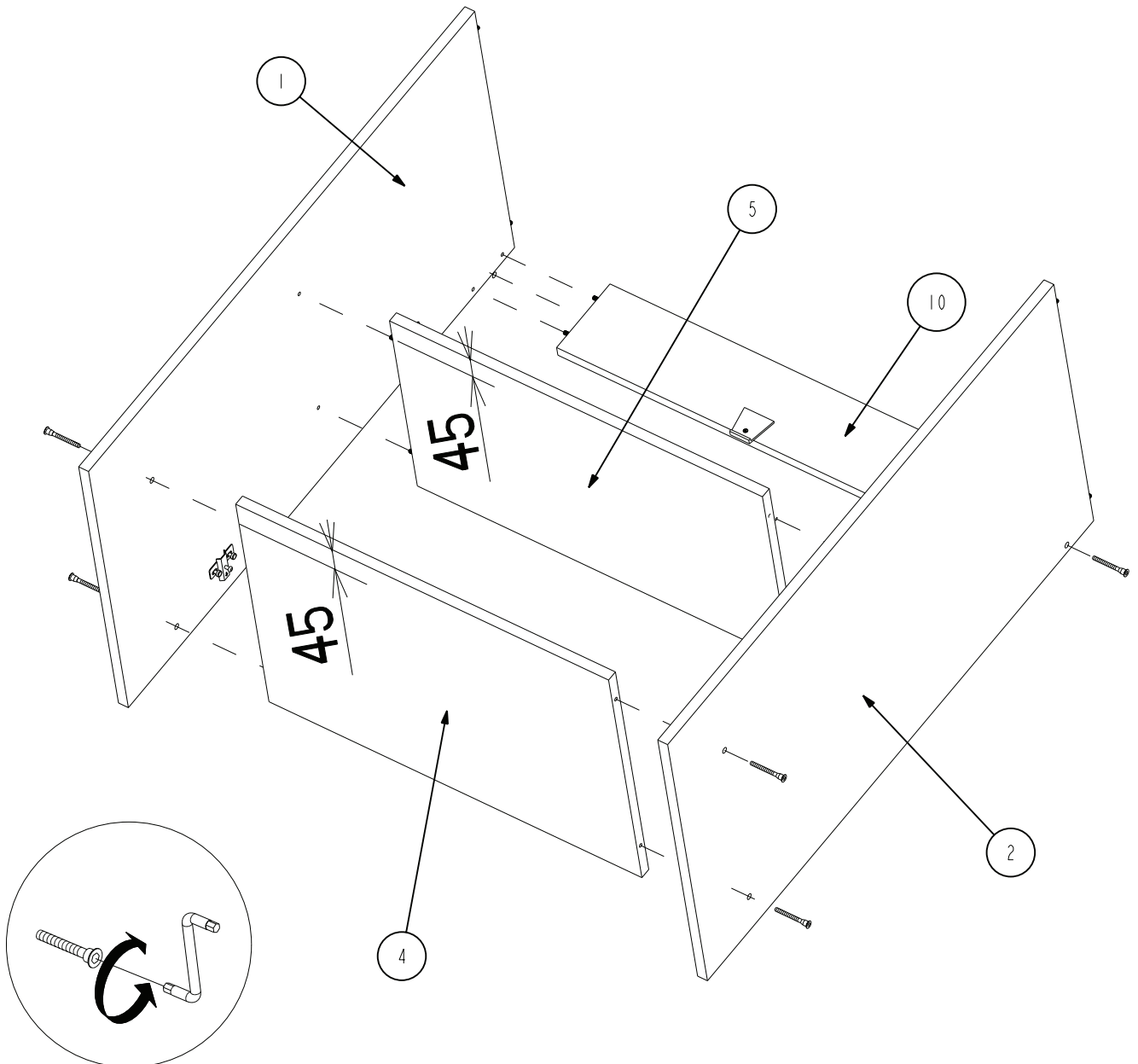

5

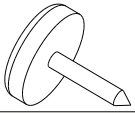
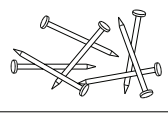
560	X 4	604757	X 1
			x30

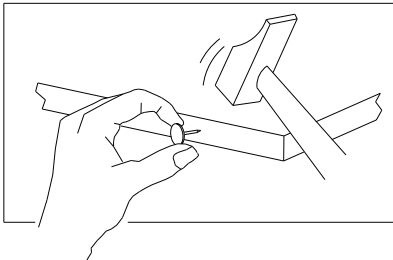
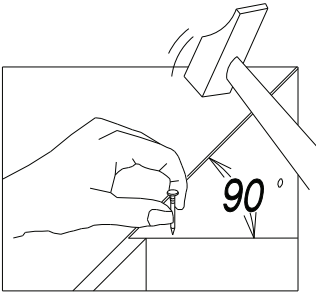
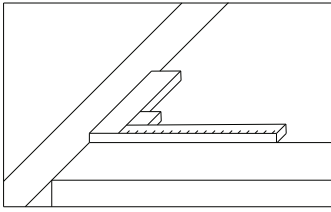

390
30

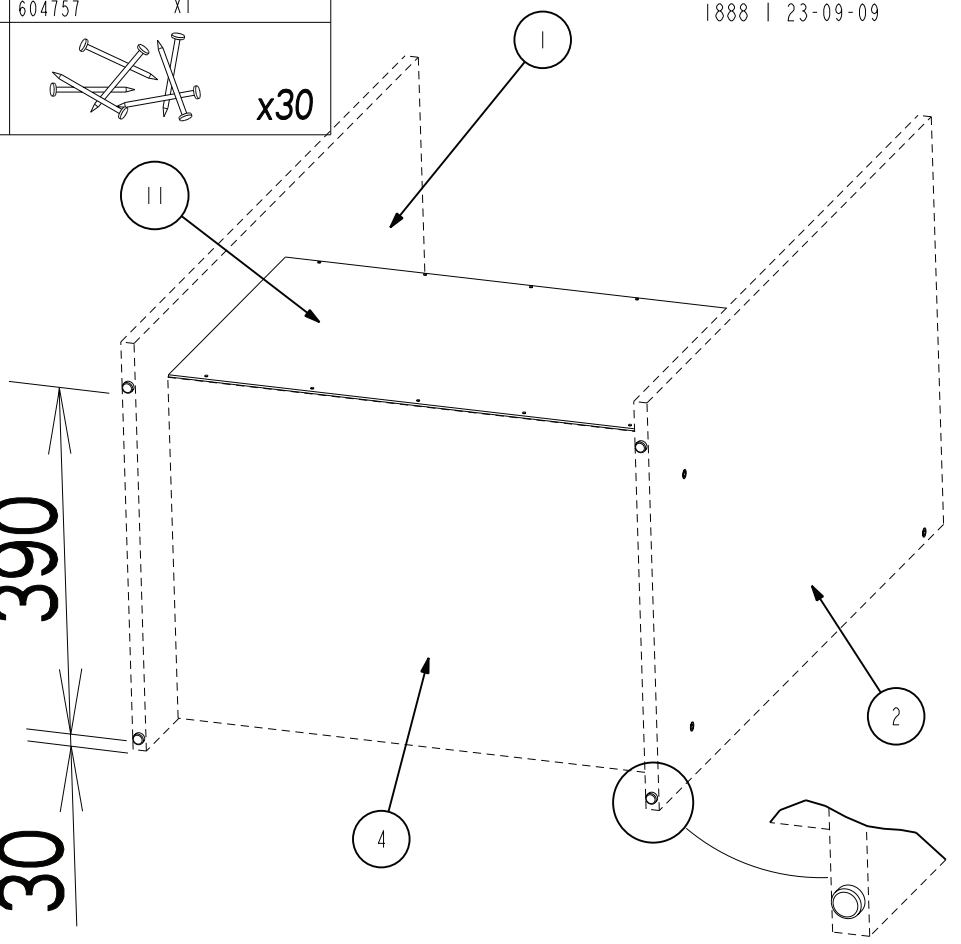

6

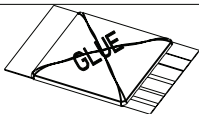

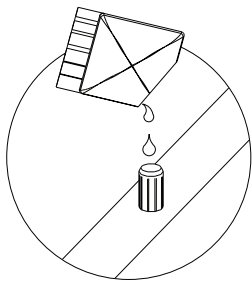
340132	X 1
	

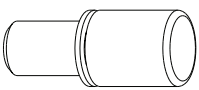

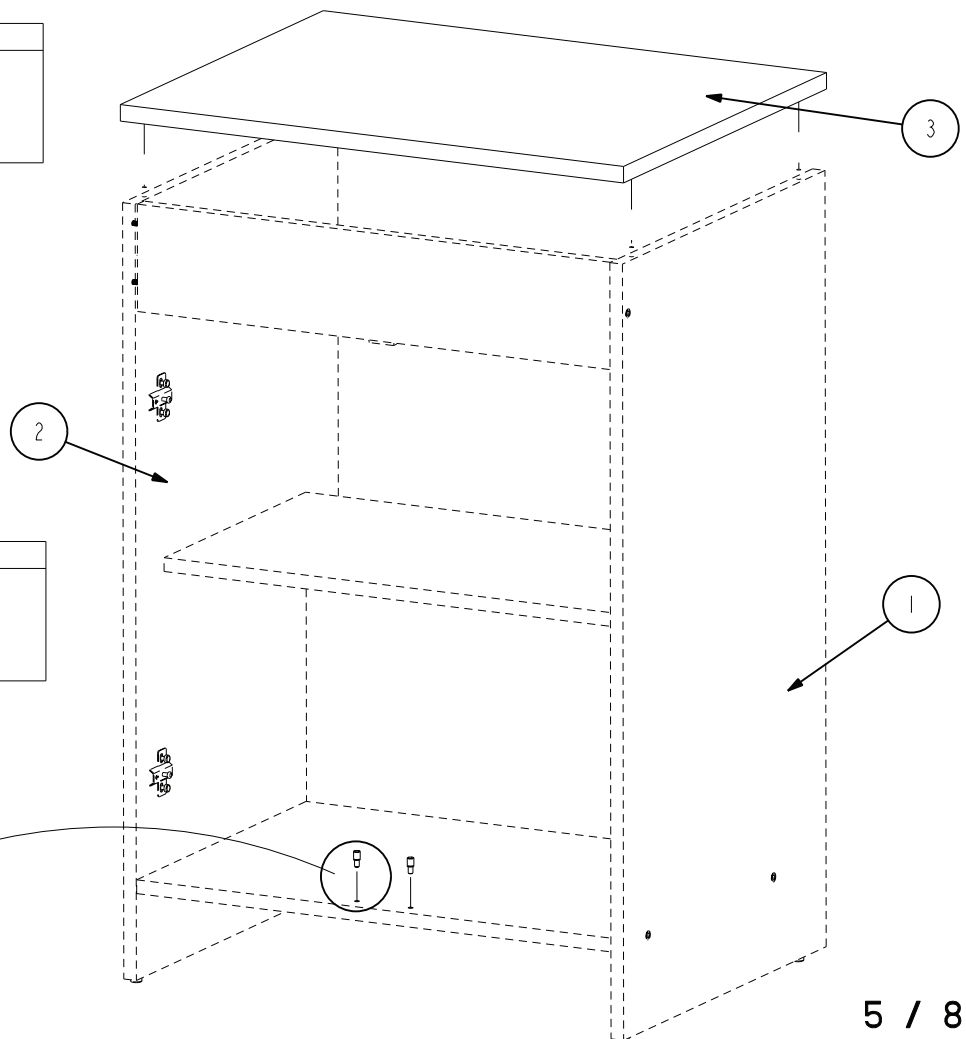

746	X 2
	

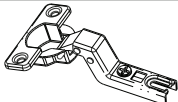
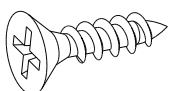

7

333010	X 4	949	X 8	332032	X 2
					
		VBA TF 4x15			

1888 23-09-09	X 4	
913		
	VBA TR 4x30	

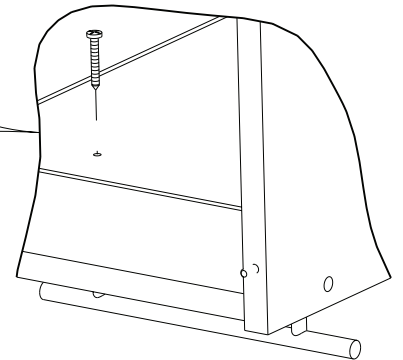
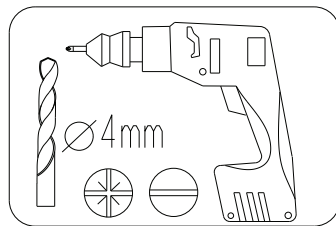
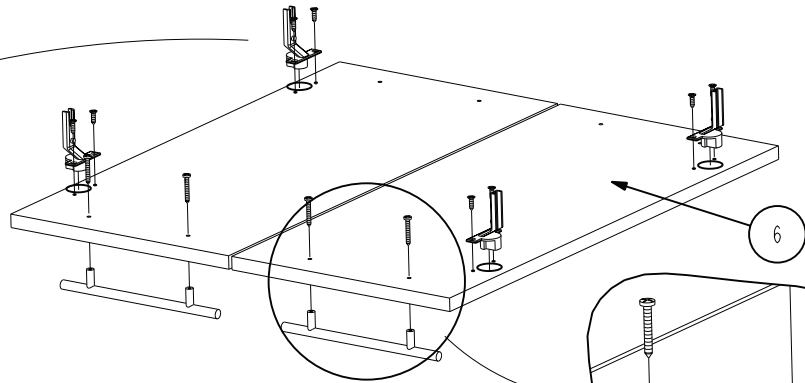
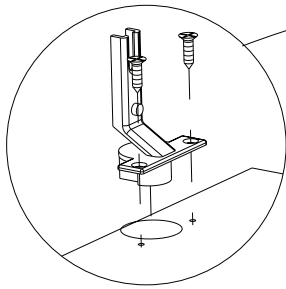

8

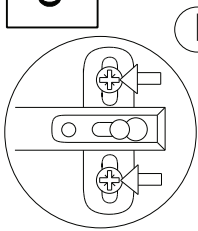

1

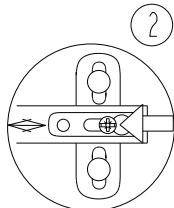
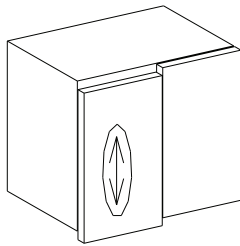

2

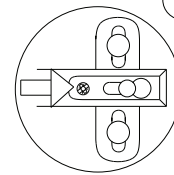
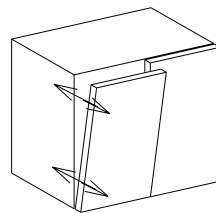

3

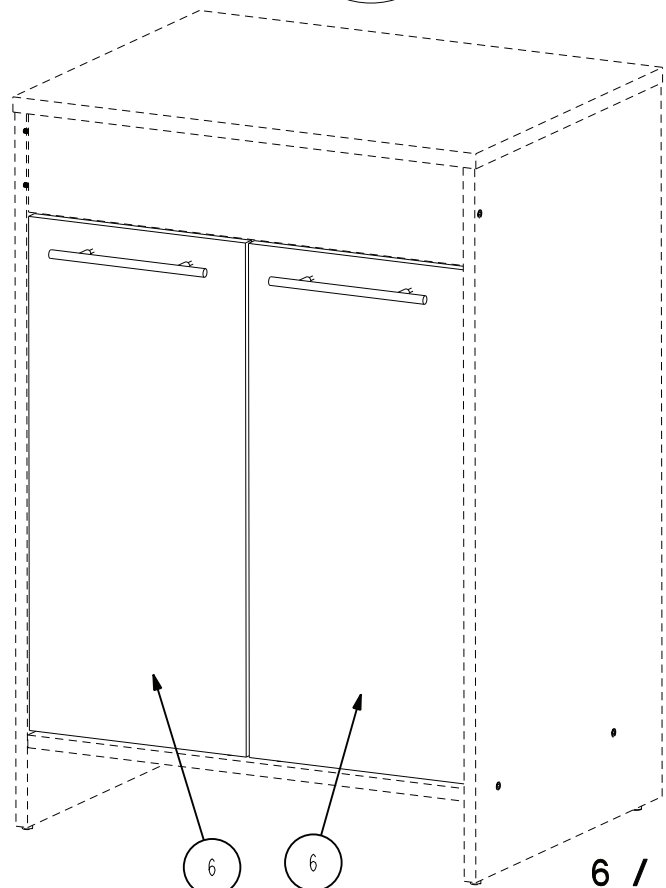
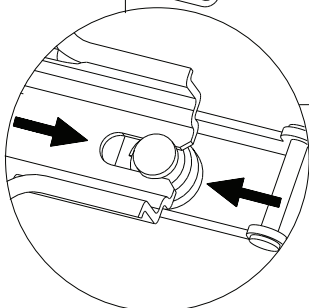
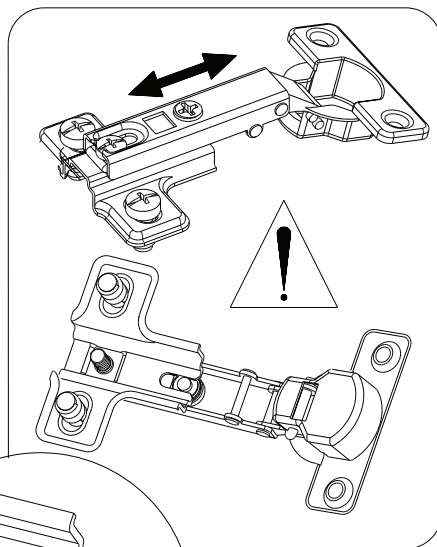
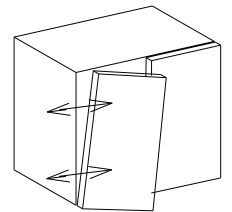

9

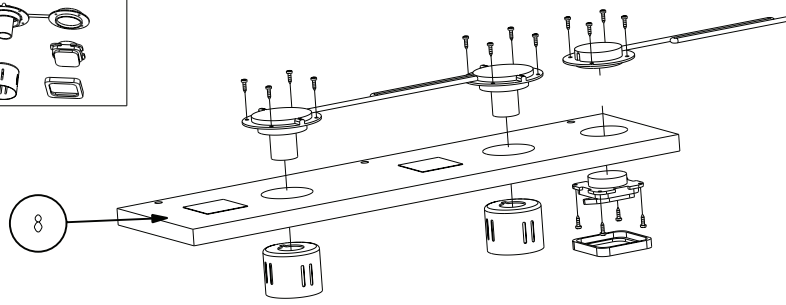
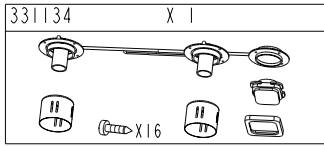

SUIVRE LE DOCUMENT ANNEXE POUR LE MONTAGE DES JOINT DOUILLE

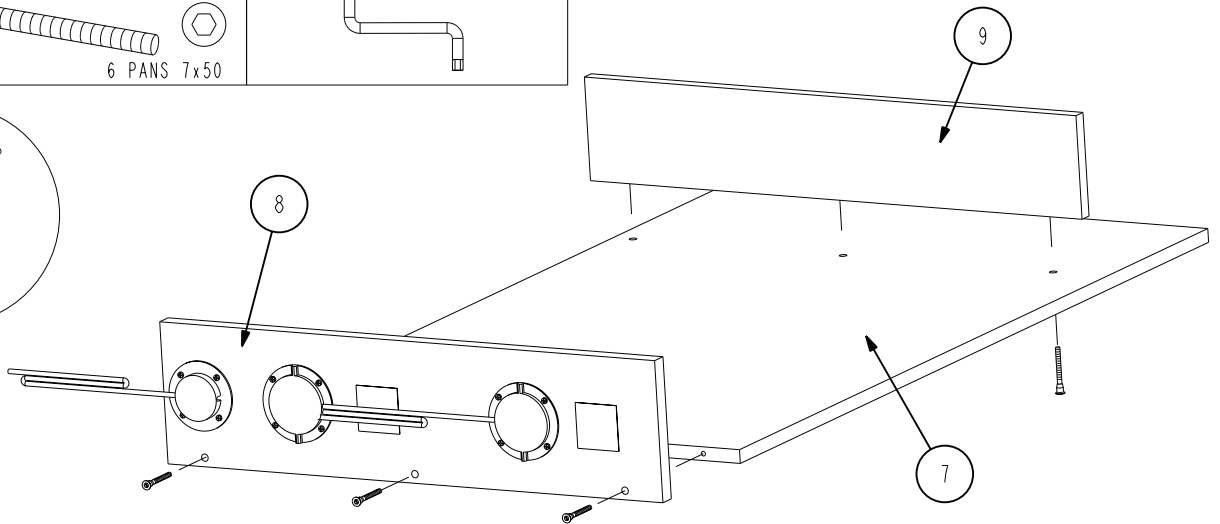
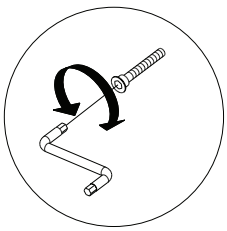
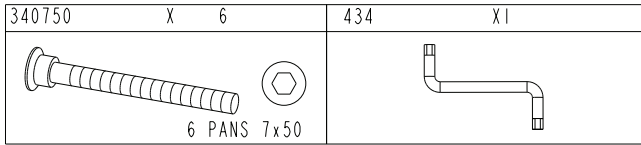

10

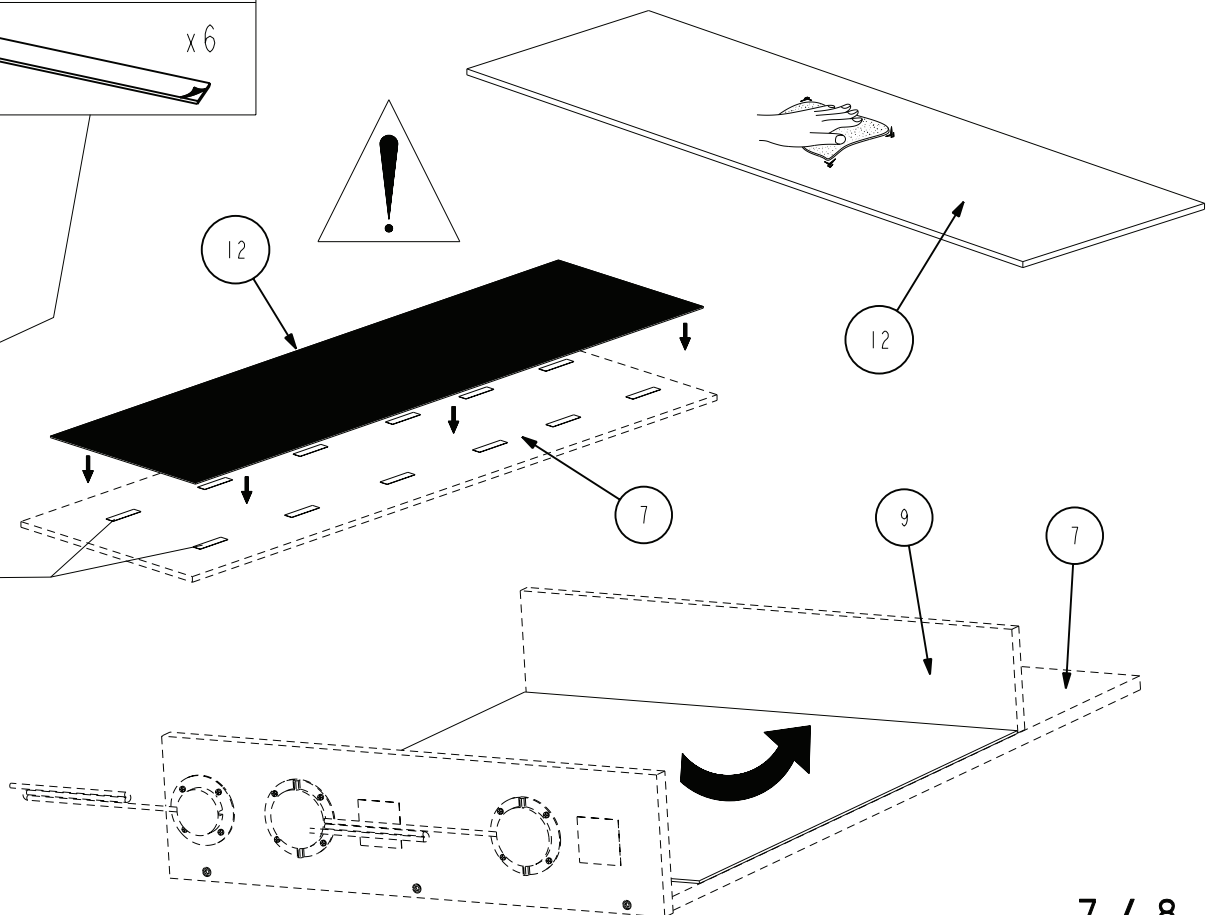
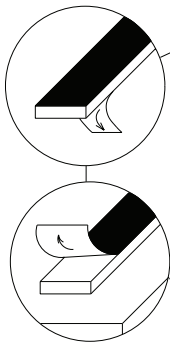
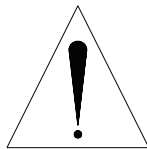
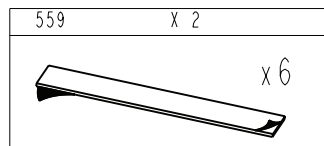

11

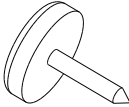

12

906	X 4	184	X 2	560	X 2
					
VBA TR 3x12					

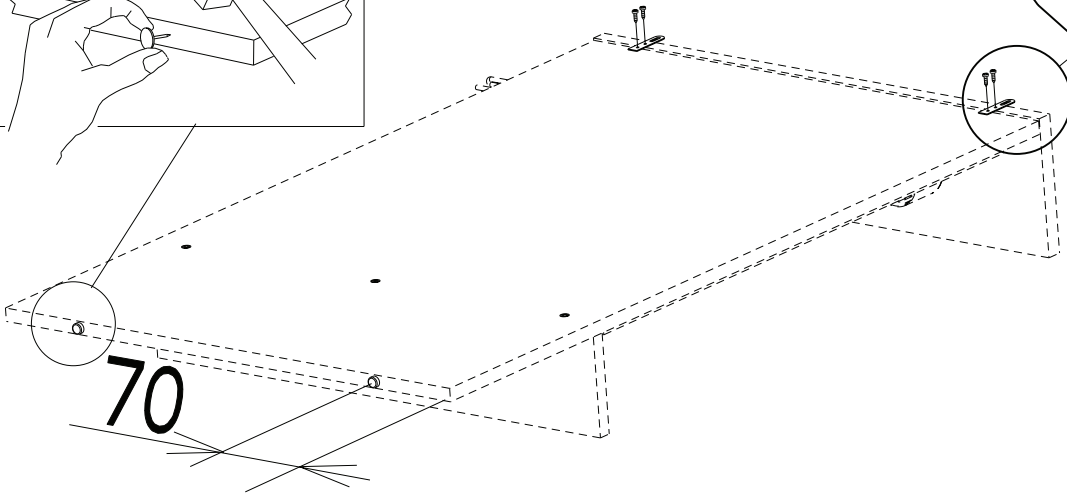
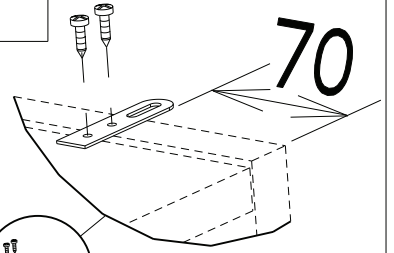
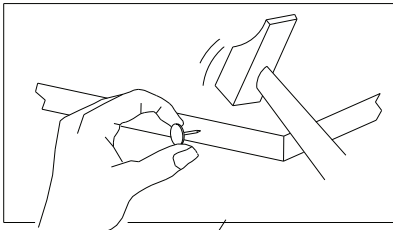

13

340042	X 6
