

Montageanleitung

Notice de montage

Assembly instruction

GERMANIA®
the furniture factory

Wickelkommode 0882

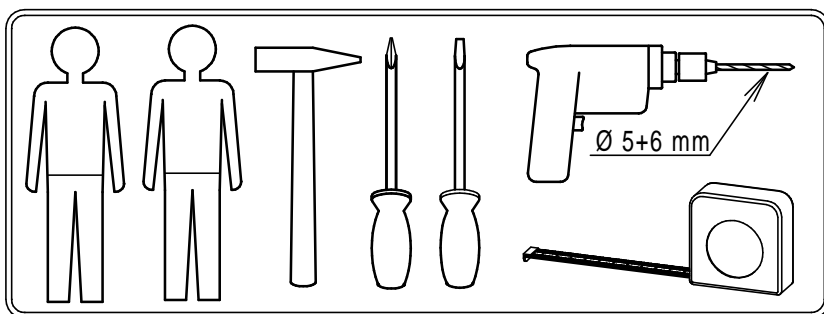
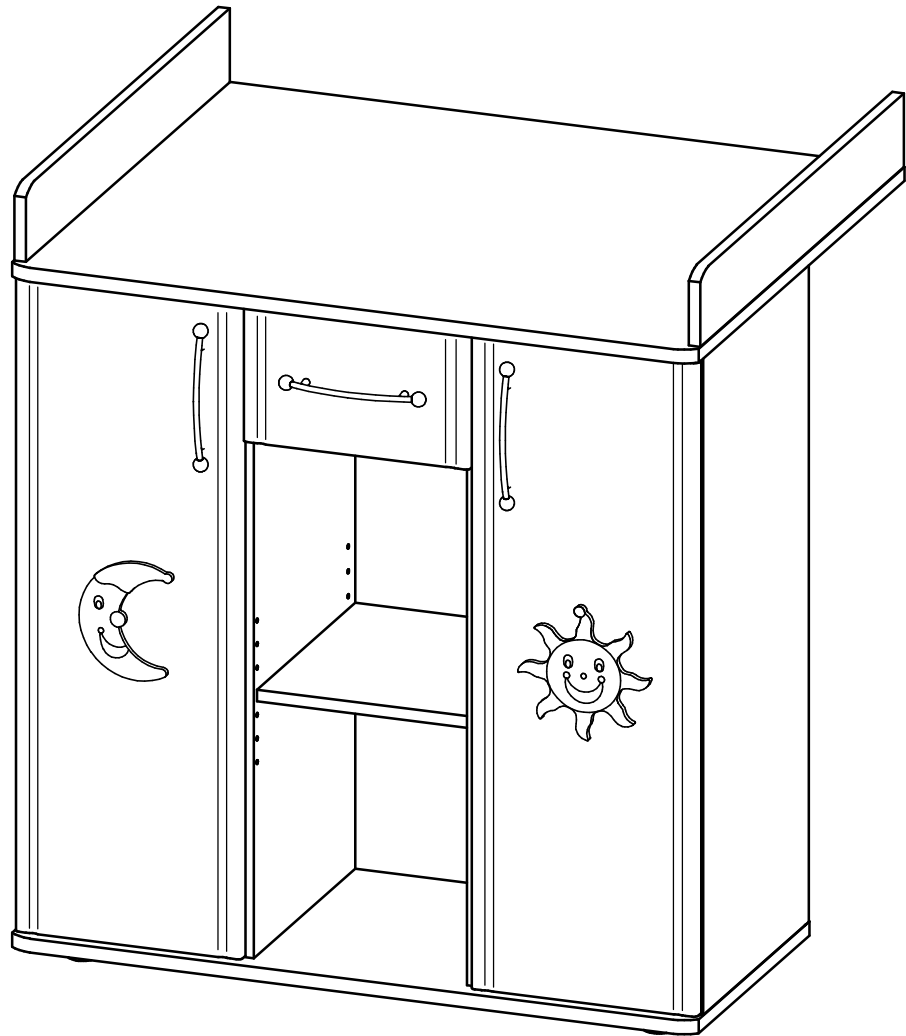











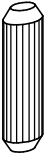

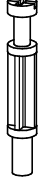
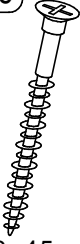
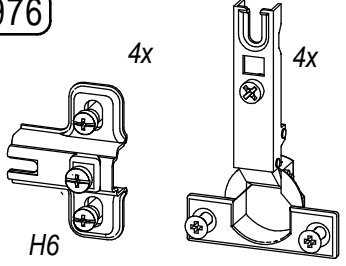

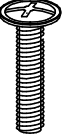
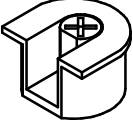
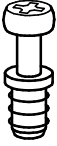
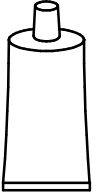
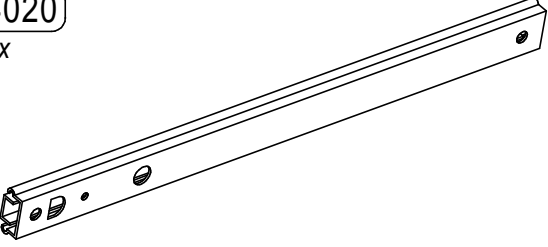

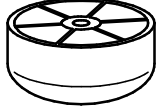
Bitte die Sicherheitshinweise auf der letzten Seite beachten!

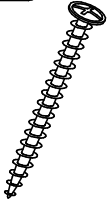
Please note: safety instructions on the last page!

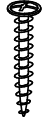
Prière de suivre les instructions de sécurité figurant sur la dernière page!

erstellt	geändert	geprüft
Datum: 24.01.12	Datum:	Datum: 27.01.12

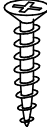
Mod. 0882 **Teileliste** - liste de pièces - partlist

<p>2218 24x</p>  <p>Ø8 x 30mm</p>	<p>1118 18x</p>  <p>Ø15 mm</p>	<p>1114 18x</p>  <p>24 mm</p>	<p>1169 12 x</p>  <p>Ø4,3x45mm</p>	<p>4976</p>  <p>4x 4x</p> <p>H6</p>	
<p>4798 3 x</p>  <p>Teilung = 128 mm</p>	<p>1045 6 x</p>  <p>M4x25</p>	<p>1260 12x</p> 	<p>1264 12x</p> 	<p>4271 1x</p> 	
<p>4020 2 x</p>  <p>246 mm</p>	<p>1236 4 x</p>  <p>Ø6,3x11</p>	<p>1235 2 x</p>  <p>M4x8</p>	<p>4014 4 x</p>  <p>Ø45 mm</p>		
<p>1187 2x</p>  <p>90x30x15</p>	<p>1110 2x</p>  <p>Ø6x30mm</p>	<p>1021 2x</p>  <p>Ø4,5x40mm</p>	<p>1298 4x</p>  <p>Ø4x15mm</p>	<p>1267 10 x</p>  <p>Ø3x16</p>	<p>1165 4 x</p>  <p>Ø4x22mm</p>
<p>2223 10 x</p>  <p>15x120mm</p>	<p>4095 6x</p>  <p>10x10x13mm</p>	<p>1058 6x</p>  <p>Ø3x15mm</p>	<p>7288 1x</p>  <p>- Lassen Sie Ihr Kind nicht unbeaufsichtigt! - Don't leave your child unsupervised! - Ne jamais laisser les enfants sans surveillance!</p>		

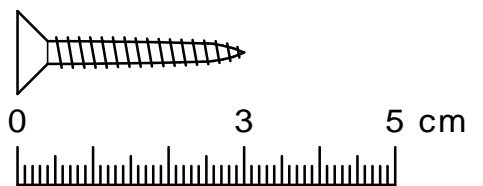

2

erstellt	geändert	geprüft
Datum: 24.01.12	Datum:	Datum: 27.01.12

Mod. 0882 **Teileliste** - liste de pièces - partlist

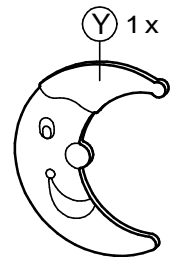
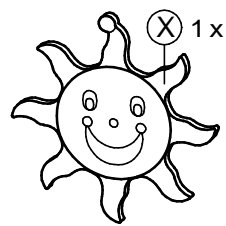
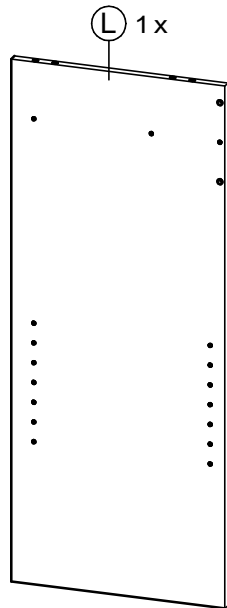
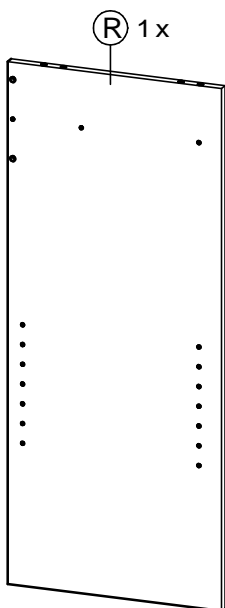
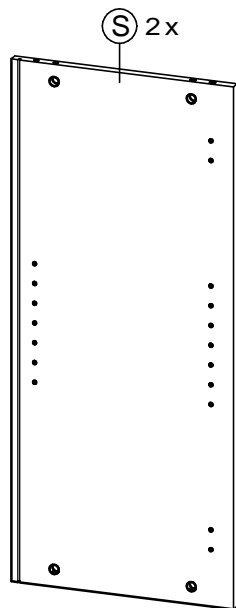
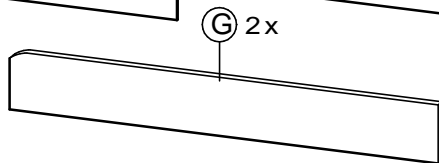
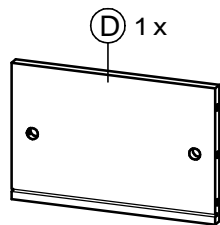
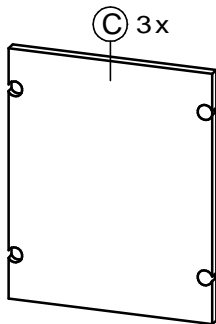
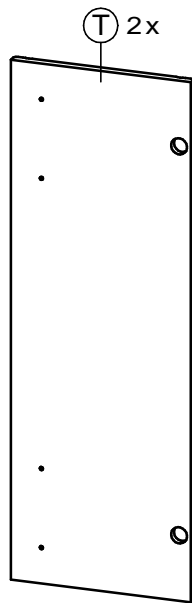
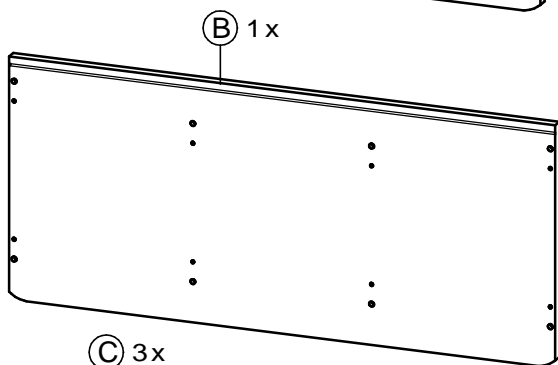
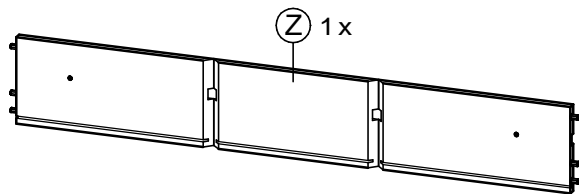
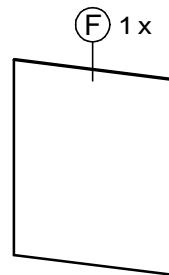
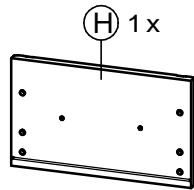
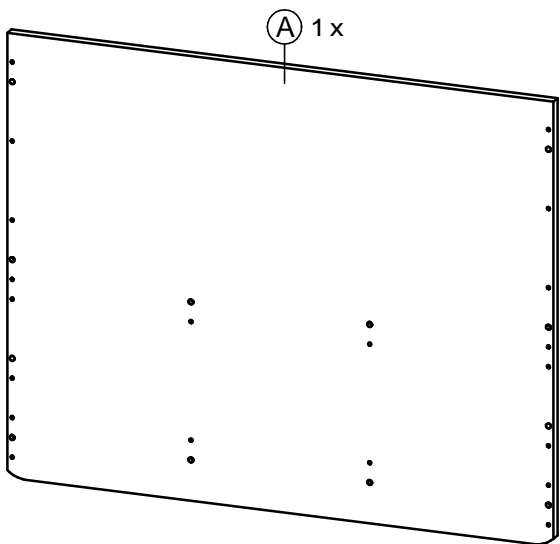

erstellt		geändert		geprüft	
Datum:	24.01.12	Datum:		Datum:	27.01.12

Mod. 0882 **Montageschritte** - ordre de montage - assembly instructions

1.

4798
1x



Teilung = 128 mm

1045
2x



M4x25

4271
1x

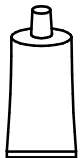

STOP

30 min.

2.

1114
8x

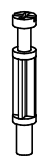

24 mm

3.

3.1

3.2

1165
4x



Ø4x22mm

1114
8x



24 mm

4014
4x



Ø45 mm

4

erstellt	geändert	geprüft
Datum: 24.01.12	Datum:	Datum: 27.01.12

Mod. 0882 **Montageschritte** - ordre de montage - assembly instructions

4.

2x

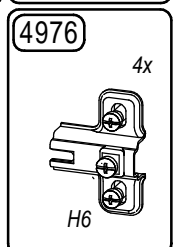
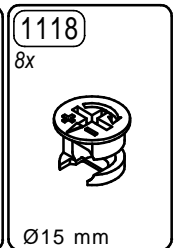
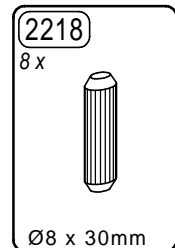
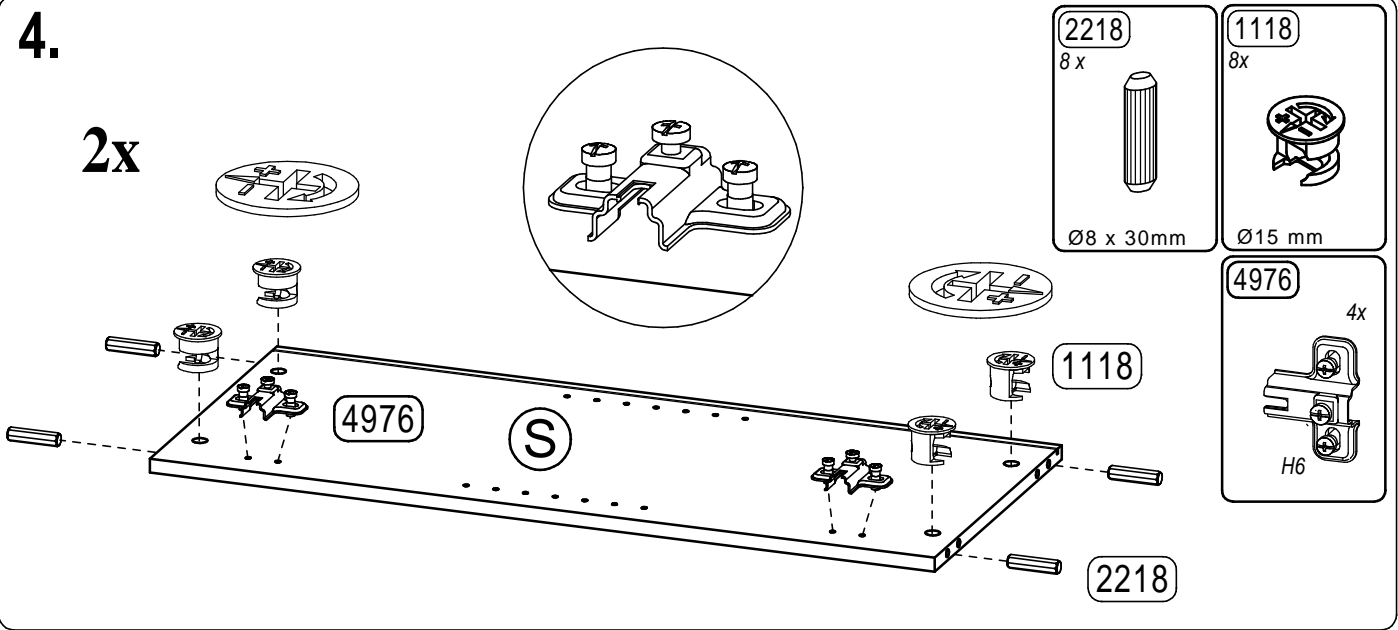

5.

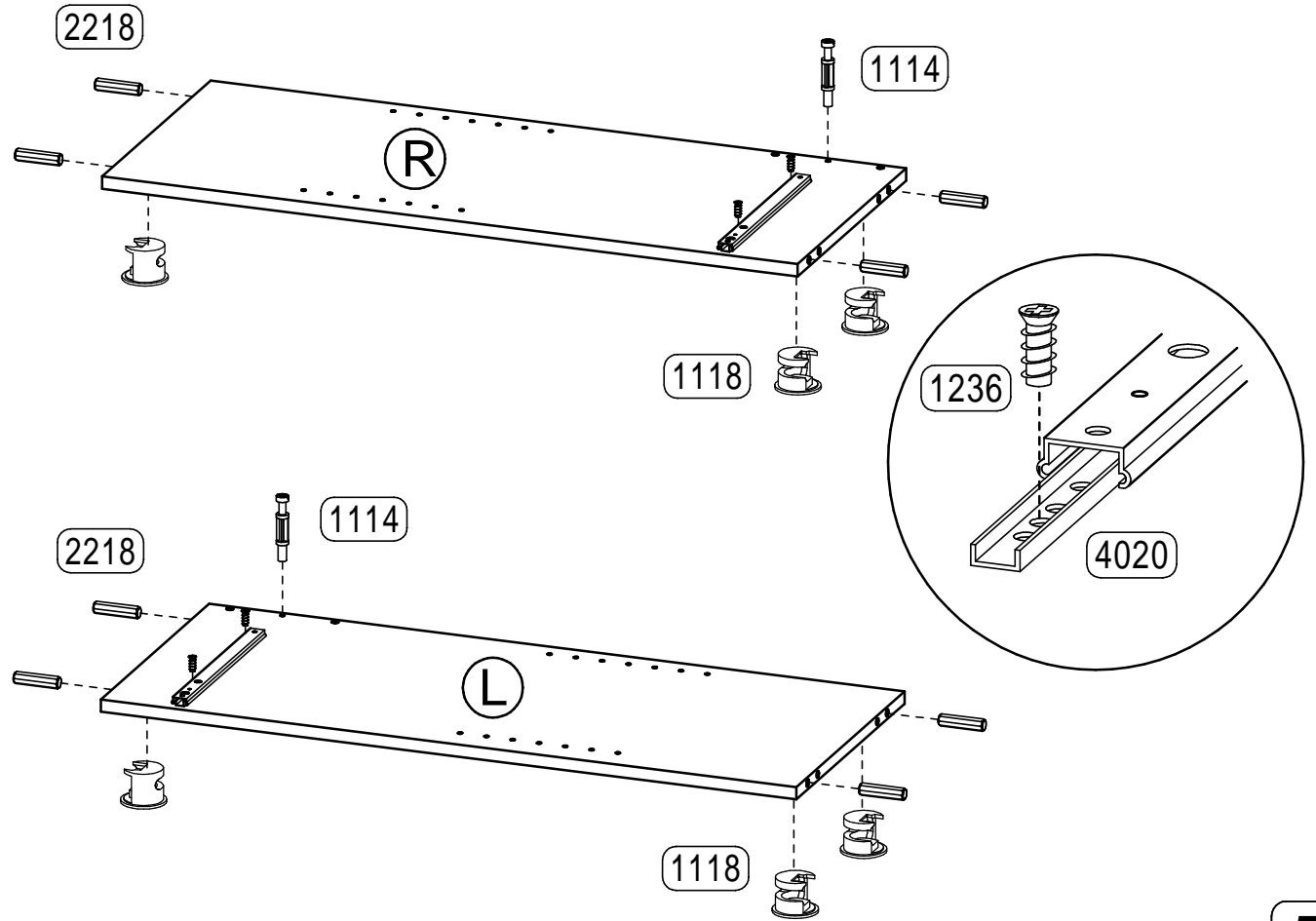
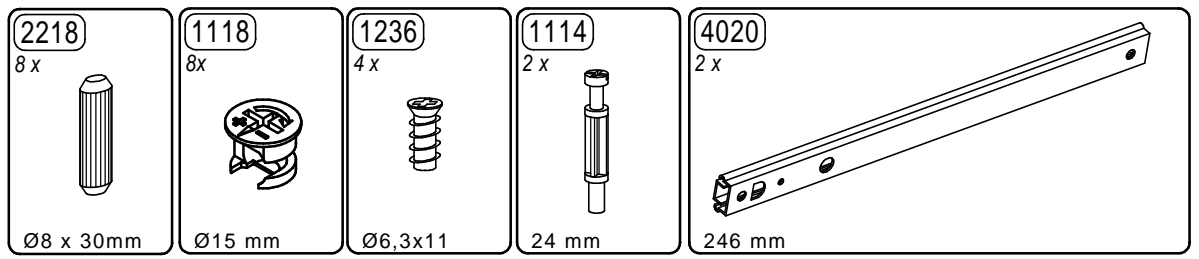

5

erstellt	geändert	geprüft
Datum: 24.01.12	Datum:	Datum: 27.01.12

Mod. 0882 Montageschritte - ordre de montage - assembly instructions

6.

2x

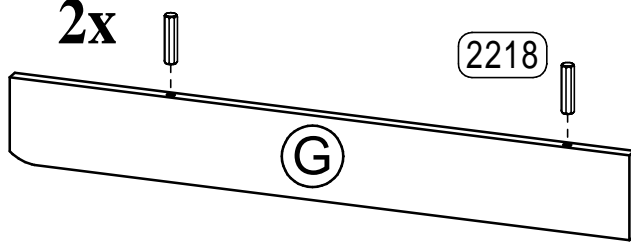

2218

7288

1x

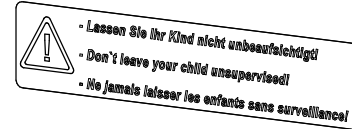

2218

4x



Ø8 x 30mm

1x

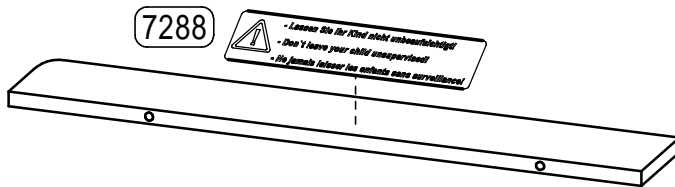

7288

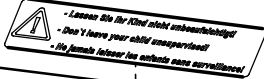

7.

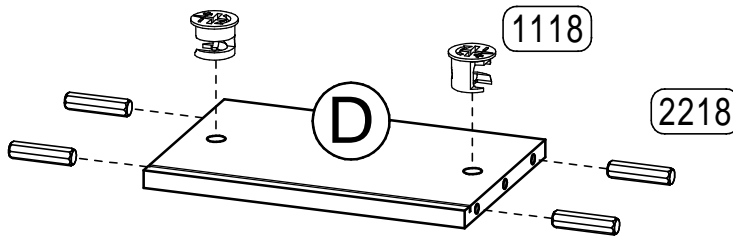

1118

2218

2218

4x



Ø8 x 30mm

1118

2x



Ø15 mm

8.

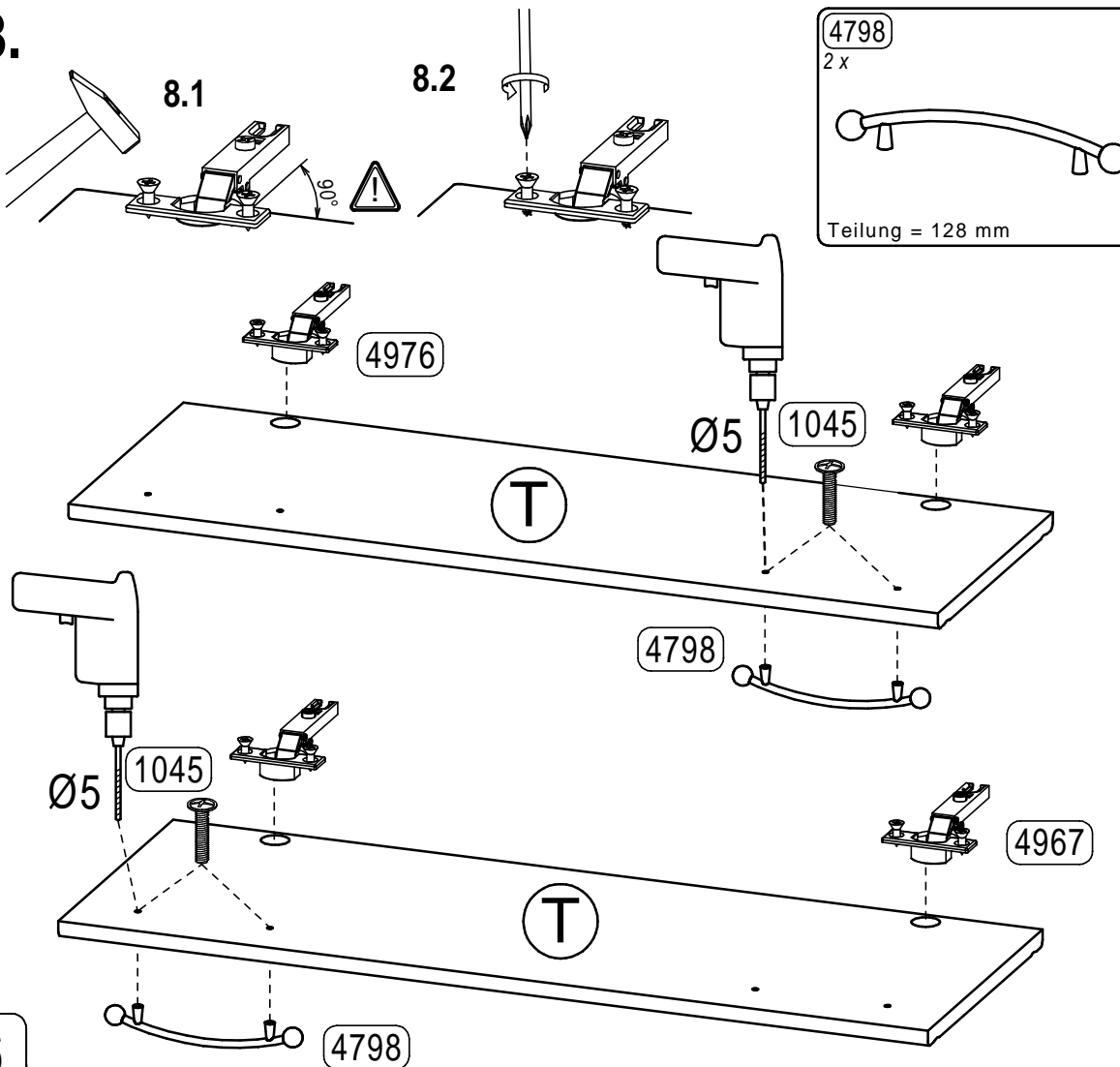

8.1

8.2

4798

2x



Teilung = 128 mm

1045

4x



M4x25

4976

Ø5

1045

4976

4x

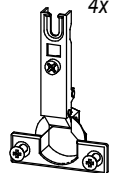

4798

Ø5

1045

4967

6

4798

erstellt

geändert

geprüft

Datum: 24.01.12

Datum:

Datum: 27.01.12

9.

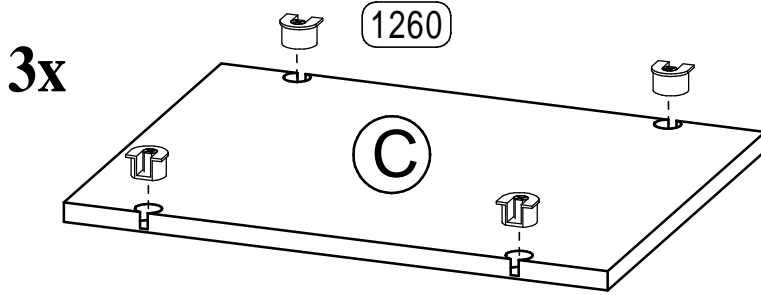

1260

12x

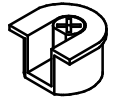

11.

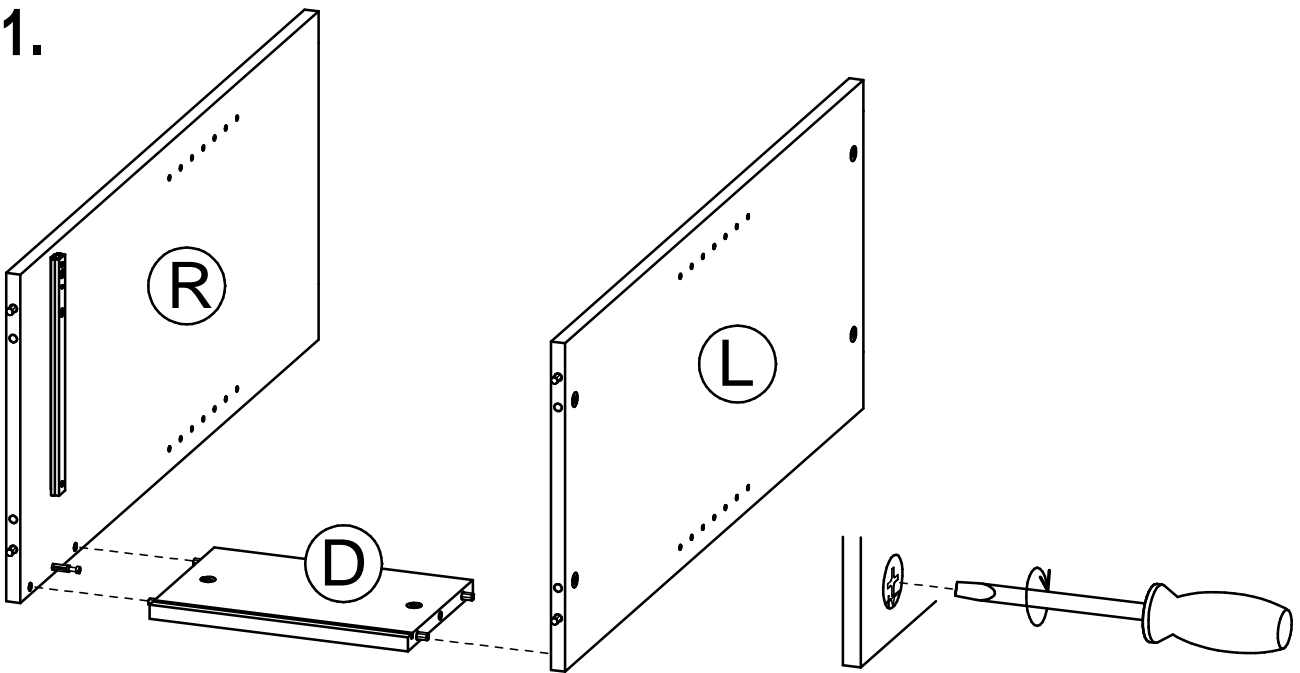

12.

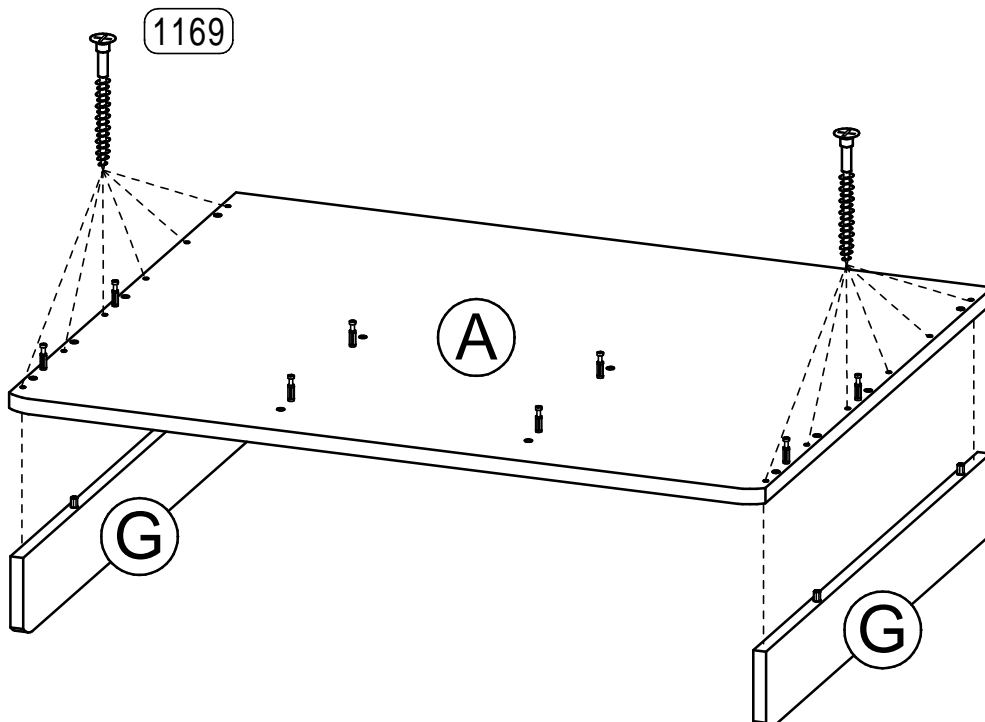

1169

12 x

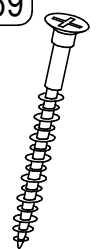

Ø4,3x45mm

erstellt

geändert

geprüft

Datum: 24.01.12

Datum:

Datum: 27.01.12

12.

12.1

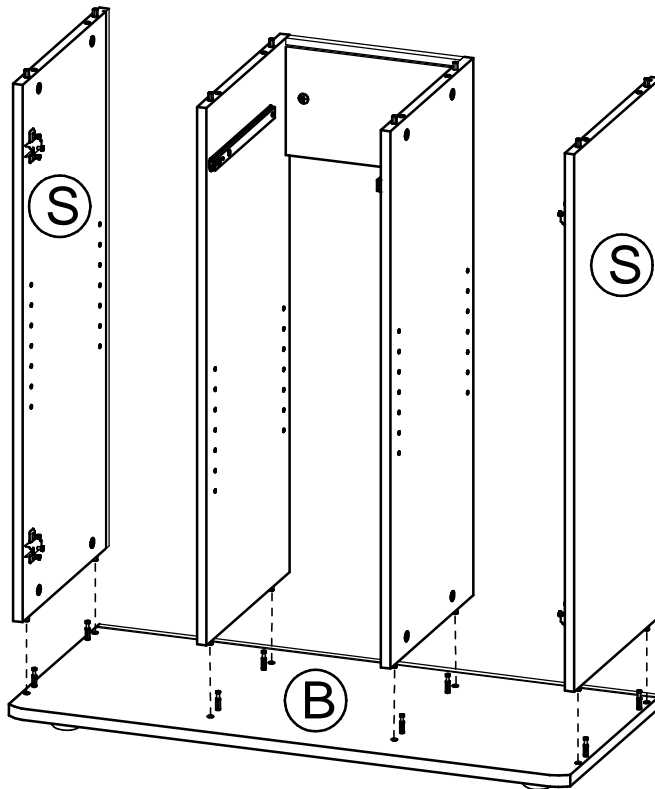

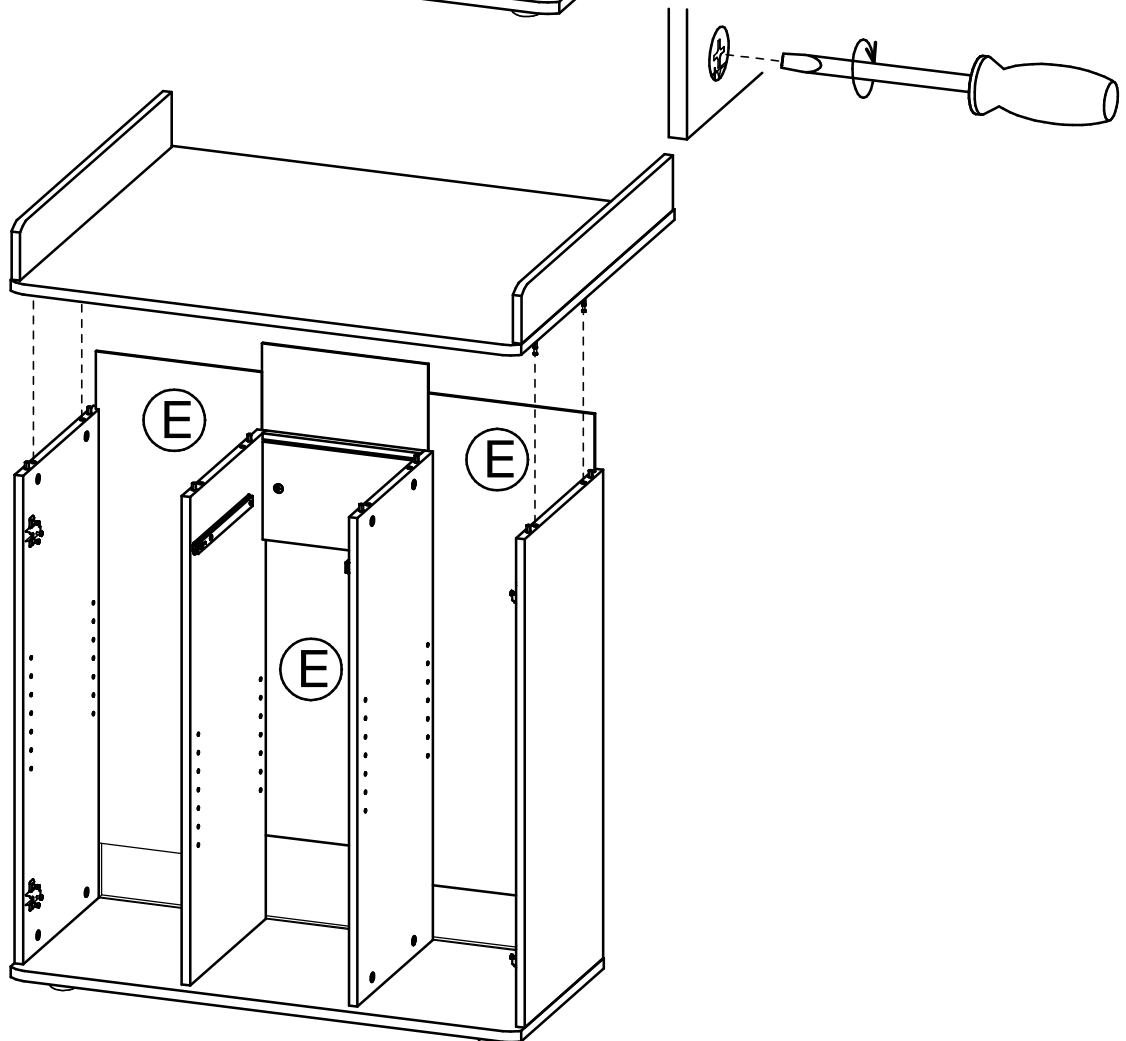

12.2

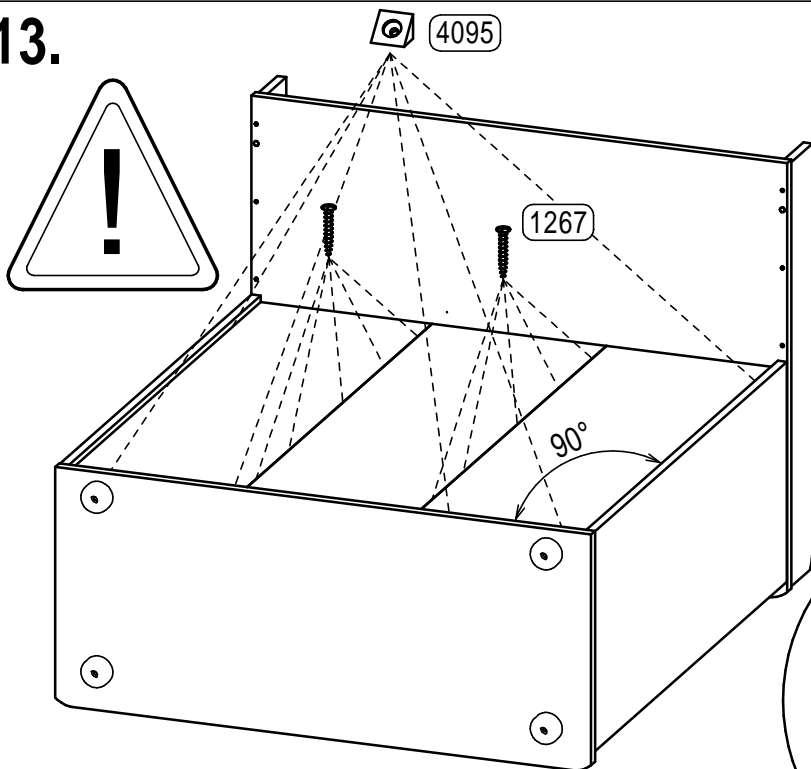

13.



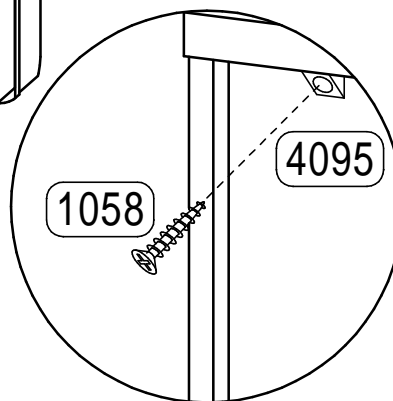

- 1267
 10 x

 Ø3x16
- 1058
 6 x

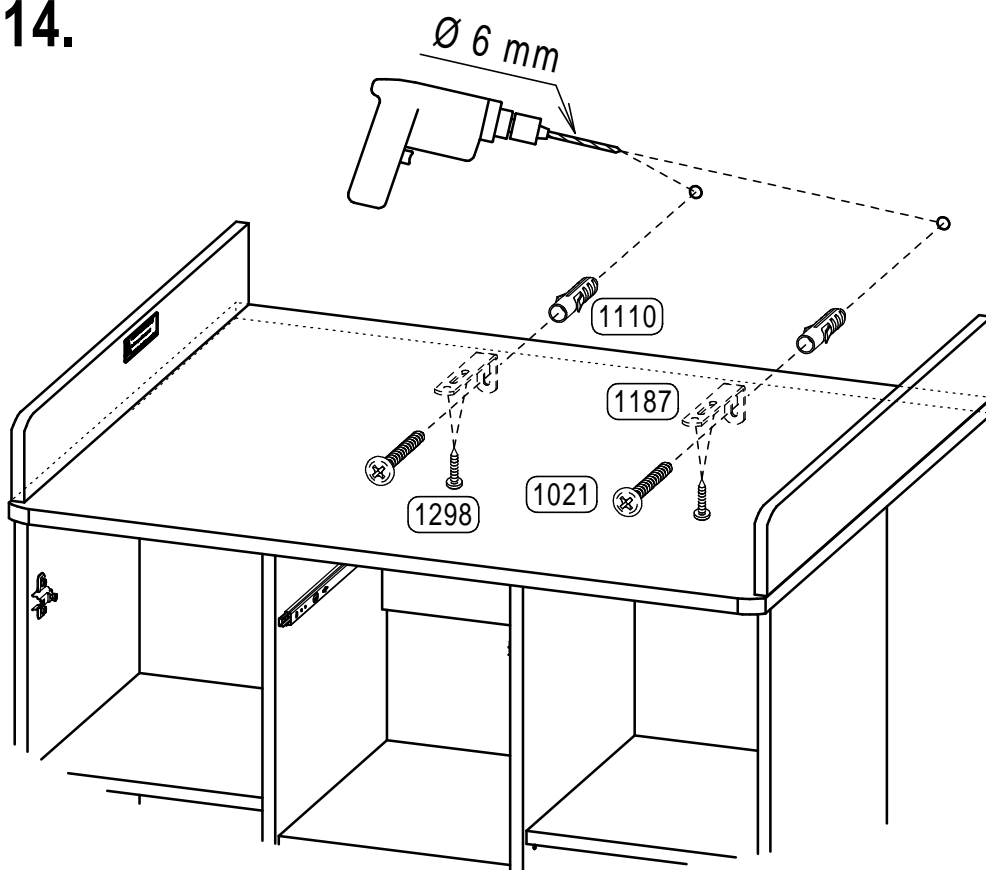
 Ø3x15mm
- 4095
 6 x

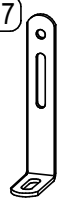
 10x10x13mm

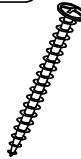

14.



- 1187
 2x

 90x30x15
- 1110
 2x

 Ø6x30mm
- 1298
 4x

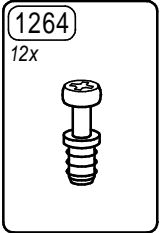
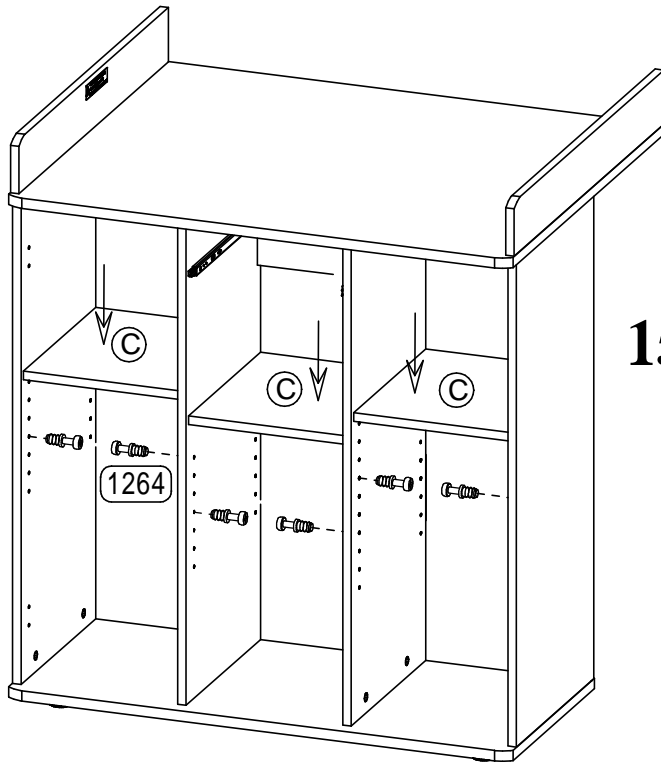
 Ø4x15mm
- 1021
 2x

 Ø4,5x40mm

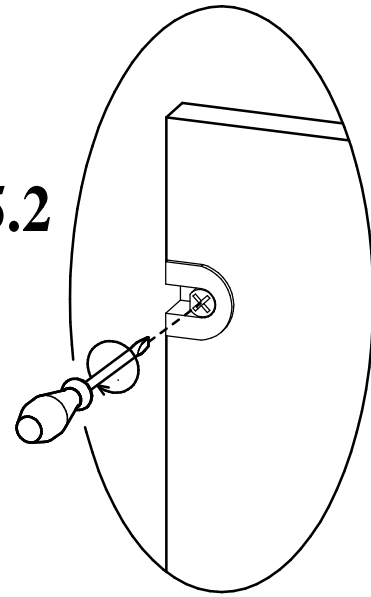
15.

15.1



15.2



16.

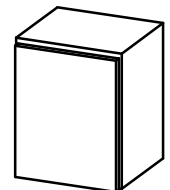
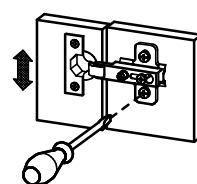
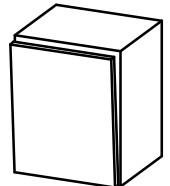
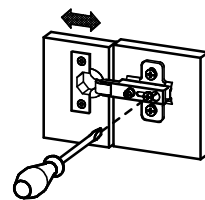
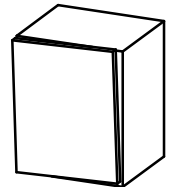
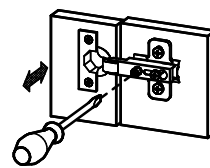
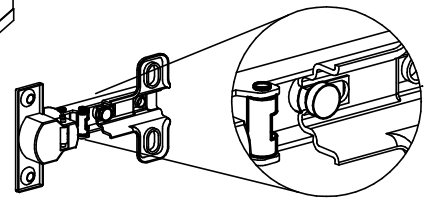
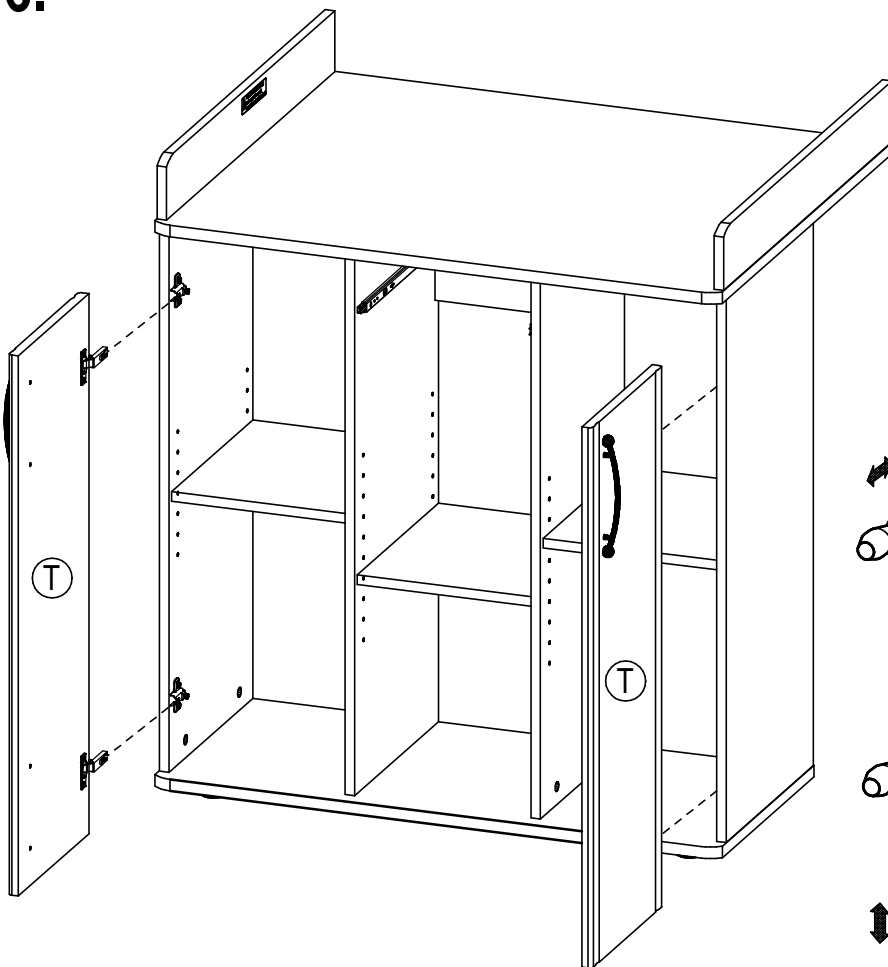

10

erstellt	geändert	geprüft
Datum: 24.01.12	Datum:	Datum: 27.01.12

17.

17.2

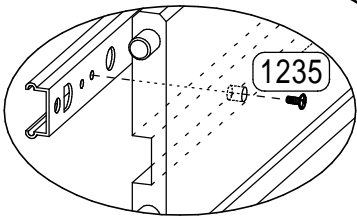
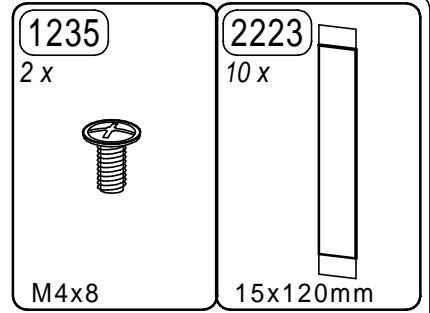
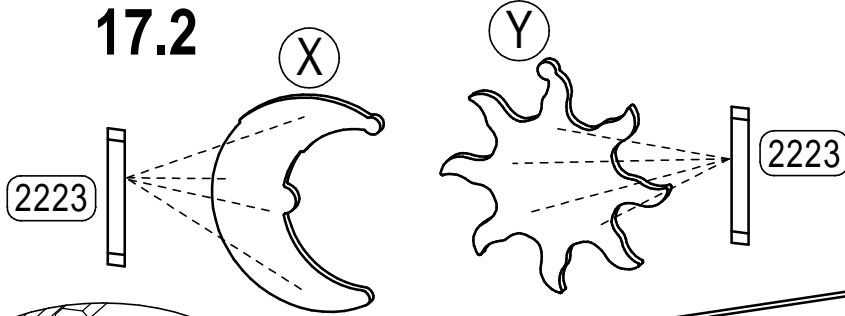

17.1

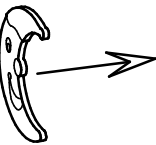
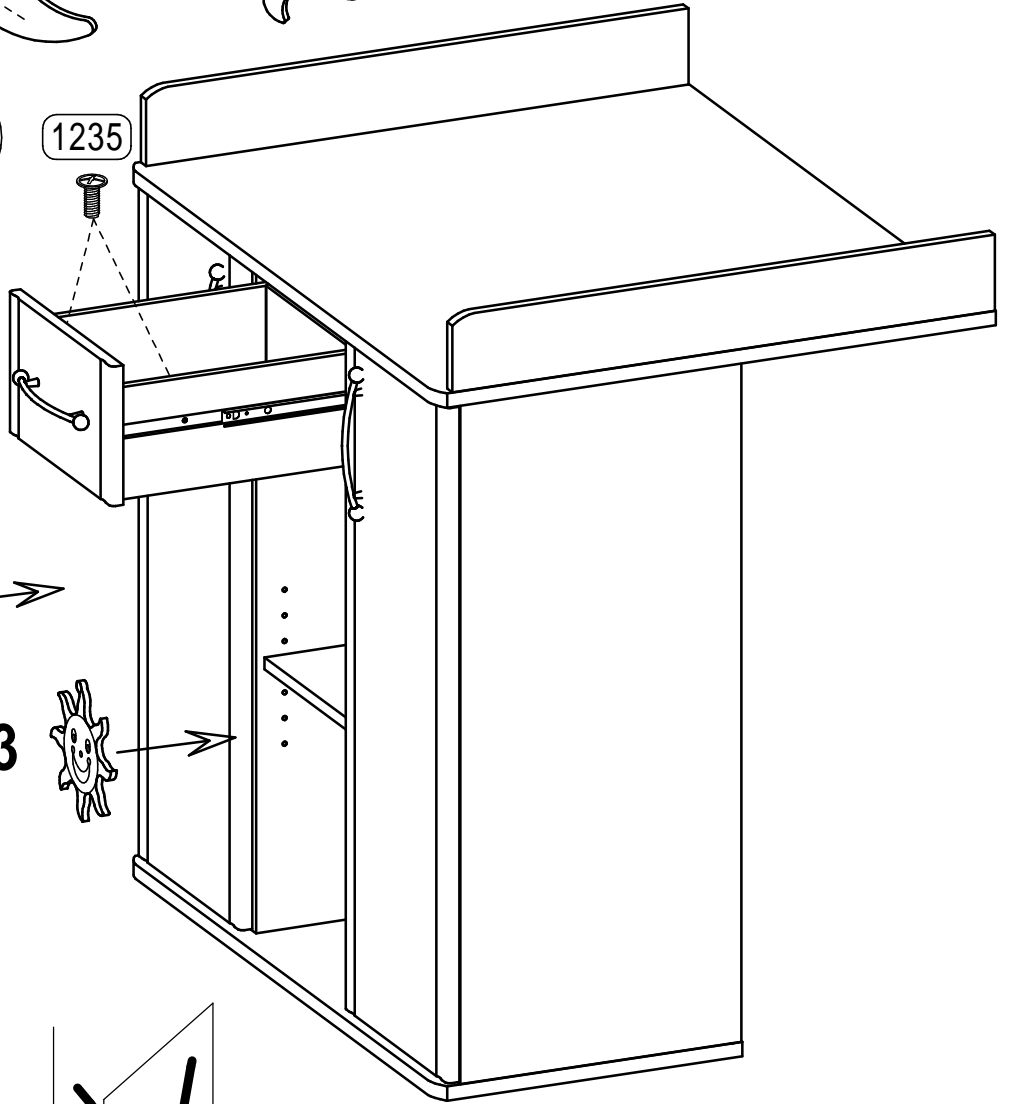

17.3

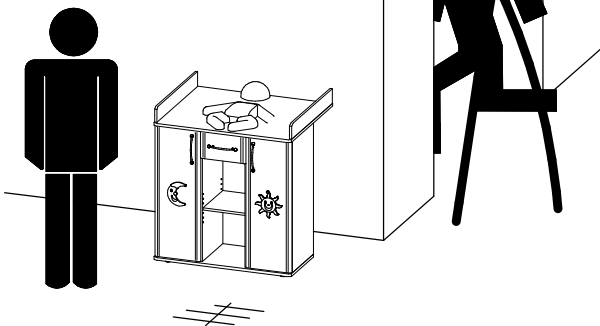
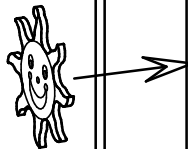

Ersatzteil-Direkt Service

(nur für Deutschland - for germany only - seulement pour Allemagne)



Sehr geehrter Kunde,
 sollte ein Möbelteil bzw. Beschlagteil fehlen oder beschädigt sein, senden Sie uns den Artikel bitte **nicht** zurück, sondern fordern Sie der Einfachheit halber Ersatz direkt bei **GERMANIA** an.
 Tragen Sie Ihren Bedarf in die Tabelle ein und übermitteln Sie uns diese Seite per Post, per Fax, telefonisch oder per e-mail.
 Bitte unbedingt die MODEL-Nr. + DEKOR-Nr. (siehe Karton) und die entsprechende Teilebezeichnung (siehe Teilliste) angeben.

Mod. Nr.: _____ Dekor-Nr.: _____

Serie
1234



Möbelteile			
Teil	beschäd.	fehlt	Anzahl
Z	X		1

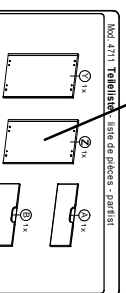

Beschlagteile			
Teil	beschäd.	fehlt	Anzahl
1162		X	2

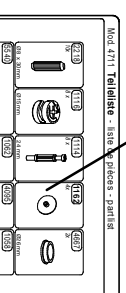

Absender nicht vergessen :

Name: _____ Strasse u. Nr.: _____
 PLZ: _____ Ort: _____
 Tel.: _____ Fax: _____ e-mail: _____

Unsere Hotline :

Tel. 05252 84939 und 05252 84962 Fax: 05252 84936
 e-mail : service@mygermania.com
GERMANIA - Service - Postfach 1160 D 33189 Schlangen

Sicherheitshinweise

Safety instructions

GERMANIA the furniture factory

Indications de sécurité

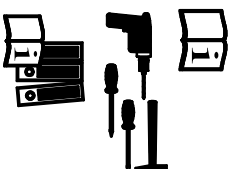

- 1.) Montageanleitung aufmerksam durchlesen
 Please read assembly instruction carefully
 Prière de bien lire la notice de montage du début à la fin
- 2.) Montage nach Montageanleitung durchführen
 Please follow the assembly instruction step by step
 Bien suivre le sens du montage indiqué sur la notice
- 3.) Montageanleitung aufbewahren
 Please save the assembly instruction
 Bien conserver la notice de montage



ACHTUNG! Beschlagbeutel und Beschlagteile von Säuglingen und Kindern fernhalten
ATTENTION! To avoid suffocation keep plastic bag away from children
 Contiens small parts which may be a choking hazard
ATTENTION! Toutes les pièces détachées livrées dans le colis être mis hors de portée des bébés des et enfants

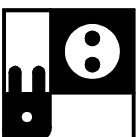
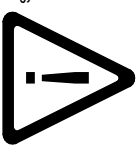

Netzanschluss (230V) nur von einem Fachmann ausführen lassen.
 Sanitäranschluss nur von einem Fachmann ausführen lassen.
 Mains connection (230V) has to be done by an expert.
 Sanitary installation has to be done by an expert.
 L'électricité (230V) uniquement à faire par un électricien.
 Installation sanitaire à faire par un spécialiste.

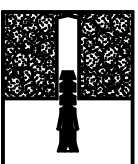
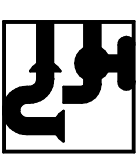

Beiliegendes Befestigungsmaterial eignet sich nur für Massivwände.
 Für andere Wände müssen Spezialdübel verwendet werden.
 Die Festigkeit ist zu Prüfen.
 The attached fixing materials is only suitable for solid walls.
 For other Types of walls special dowels have to be used.
 The firmness have to be checked.
 Le matériel de fixation ci-joint est exclusivement prévu pour des murs pleins(une fixation spéciale est nécessaire pour cloisons placo...).
 La fermeté est à examiner.

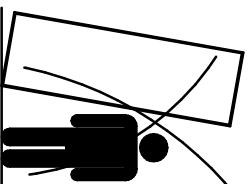

Beiliegende Wandbefestigungen dienen als Kippschutz,
 unbedingt anbringen!
 The attached wall fixing is necessary to avoid tipping
 and must be fixed!
 Les fixations prévues dans le colis préviennent contre le renversement du meuble. Il faut impérativement fixer le meuble au mur, afin d'éviter tout incident!

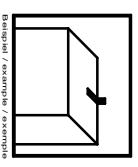

Für Schäden, die durch unsachgemäße Montage entstanden sind, übernehmen wir keine Haftung
 For the damages, which have originated from improper assembly, we take over no liability.
 Pour les dommages qui sont nés par le montage incorrect, nous ne prenons en charge aucune responsabilité.