

Montageanleitung

Notice de montage

Assembly instruction

GERMANIA[®]
the furniture factory

Schuhschrank 1178

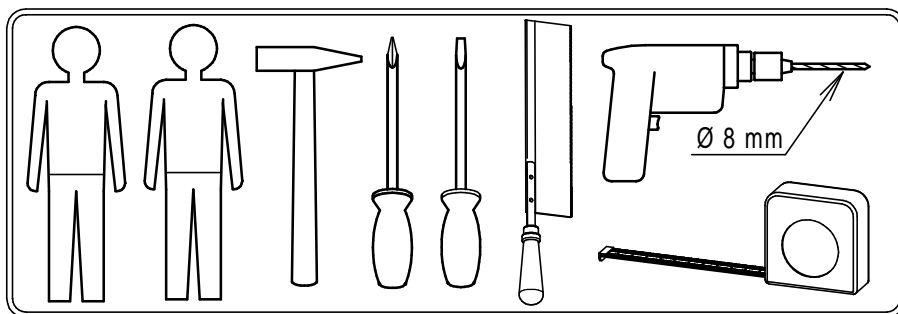
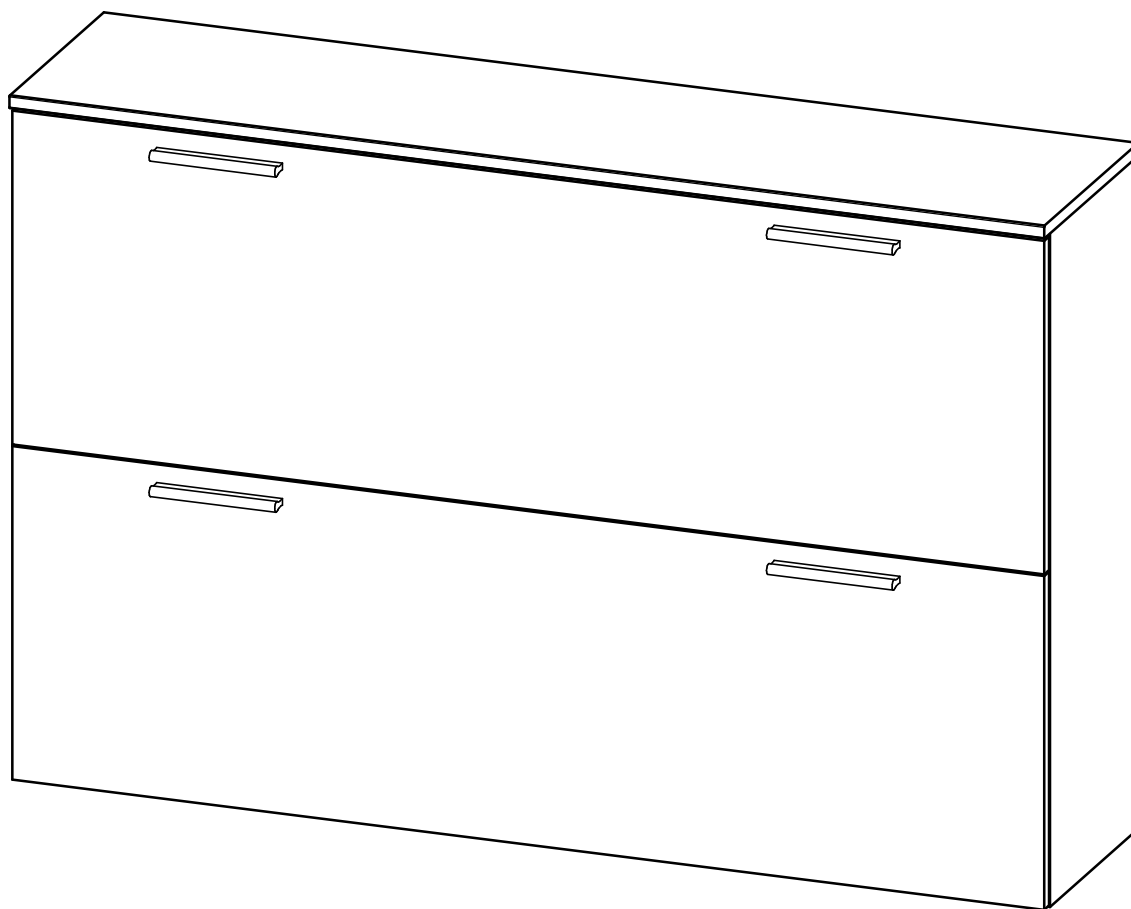

Bitte die Sicherheitshinweise auf der letzten Seite beachten!
Please note: safety instructions on the last page!

Prière de suivre les instructions de sécurité figurant sur la dernière page!

erstellt

geändert











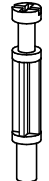
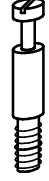

geprüft

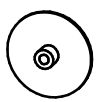
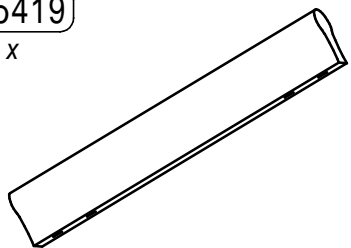
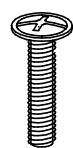
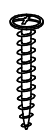
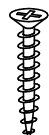
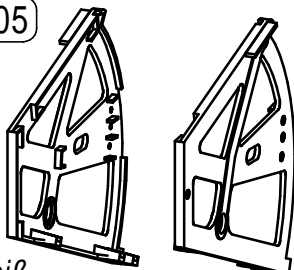
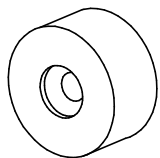
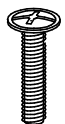
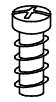
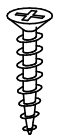
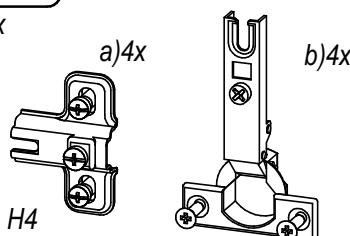
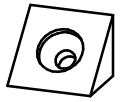
Datum: 06.07.09

Datum:

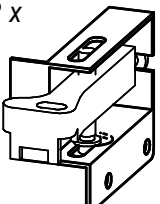
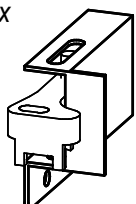
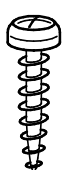
Datum: 08.07.09

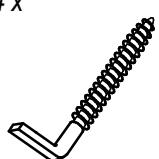
Mod. 1178 Teileliste - liste de pièces - partlist

<p>2218 16 x</p>  <p>Ø8 x 30mm</p>	<p>1116 16 x</p>  <p>Ø15mm</p>	<p>1114 14 x</p>  <p>24 mm</p>	<p>4051 2 x</p>  <p>M4, 24 mm</p>	<p>1129 3 x</p>  <p>M4, Ø5x15</p>	<p>2833 2 x</p>  <p>Ø8x50mm</p>
<p>1162 8 x</p> 	<p>5419 4 x</p>  <p>Teilung = 96 mm / 128 mm</p>	<p>1133 8 x</p>  <p>M4x21mm</p>	<p>1267 14 x</p>  <p>Ø3x16</p>	<p>1069 4 x</p>  <p>Ø4x22</p>	
<p>4305 4 x</p>  <p>weiß</p>	<p>4192 8 x</p>  <p>Ø 20 mm</p>	<p>1321 4 x</p>  <p>M4 x 17 mm</p>	<p>1238 16 x</p>  <p>Ø6,3x13</p>	<p>1058 26 x</p>  <p>Ø3x15mm</p>	
<p>4836 1x</p>  <p>H4</p>	<p>4095 2 x</p>  <p>10x10x13mm</p>	<p>1302 8 x</p>  <p>M4x10mm</p>	<p>1096 8 x</p>  <p>Ø 4,3 mm</p>	<p>4054 8 x</p>  <p>Ø 8 x 11 mm</p>	
<p>5225 2 x</p> 	<p>5226 2 x</p> 	<p>1081 8 x</p>  <p>Ø4x15</p>	<p>1111 4 x</p>  <p>Ø8x40mm</p>	<p>1289 4 x</p>  <p>Ø5,5x55mm</p>	<p>1303 1x</p>  <p>sw 3</p>

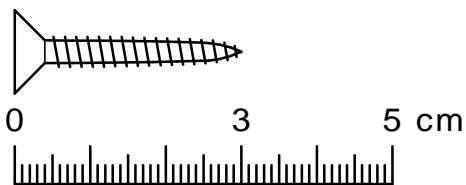

Mod. 1178 **Teileliste** - liste de pièces - partlist

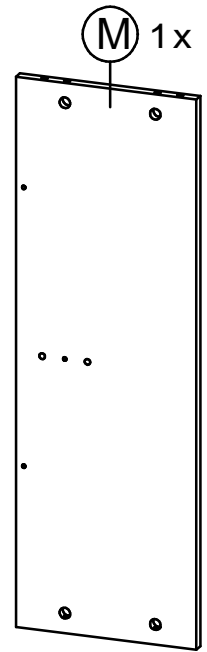
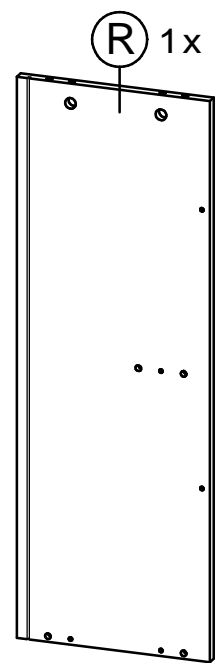
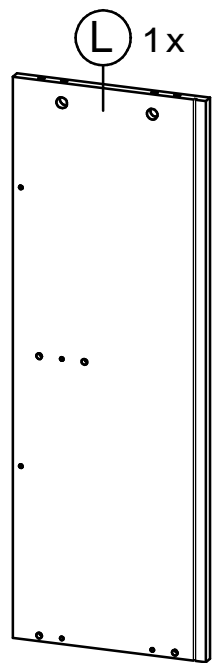
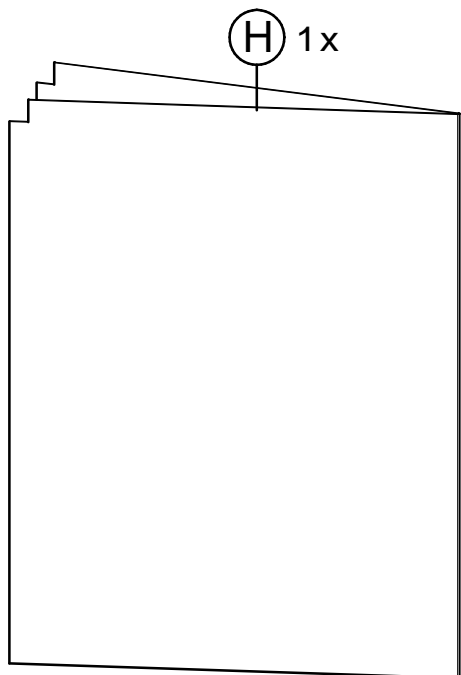
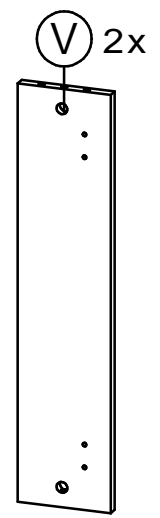
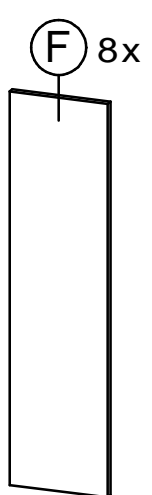
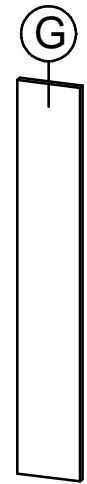
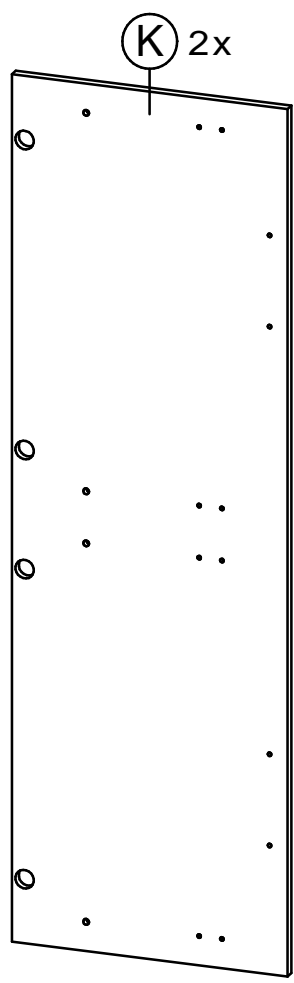
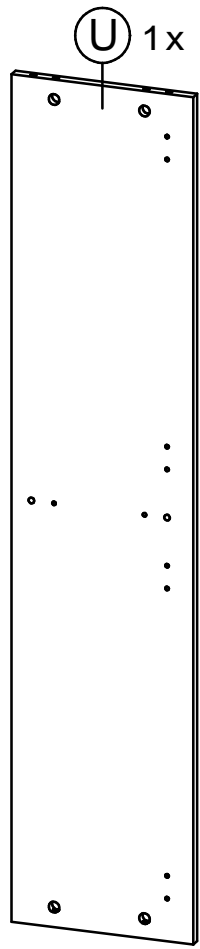
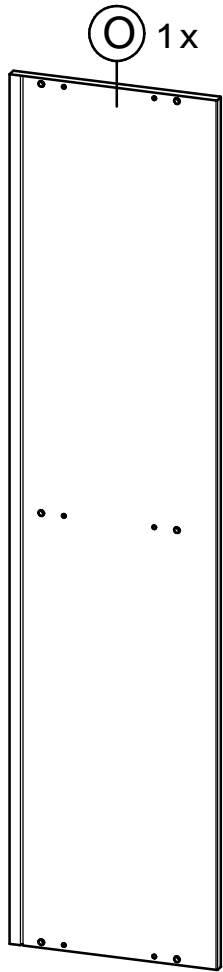

erstellt		geändert		geprüft	
Datum: 06.07.09		Datum:		Datum: 08.07.09	

Mod. 1178 Montageschritte - ordre de montage - assembly instructions

1.

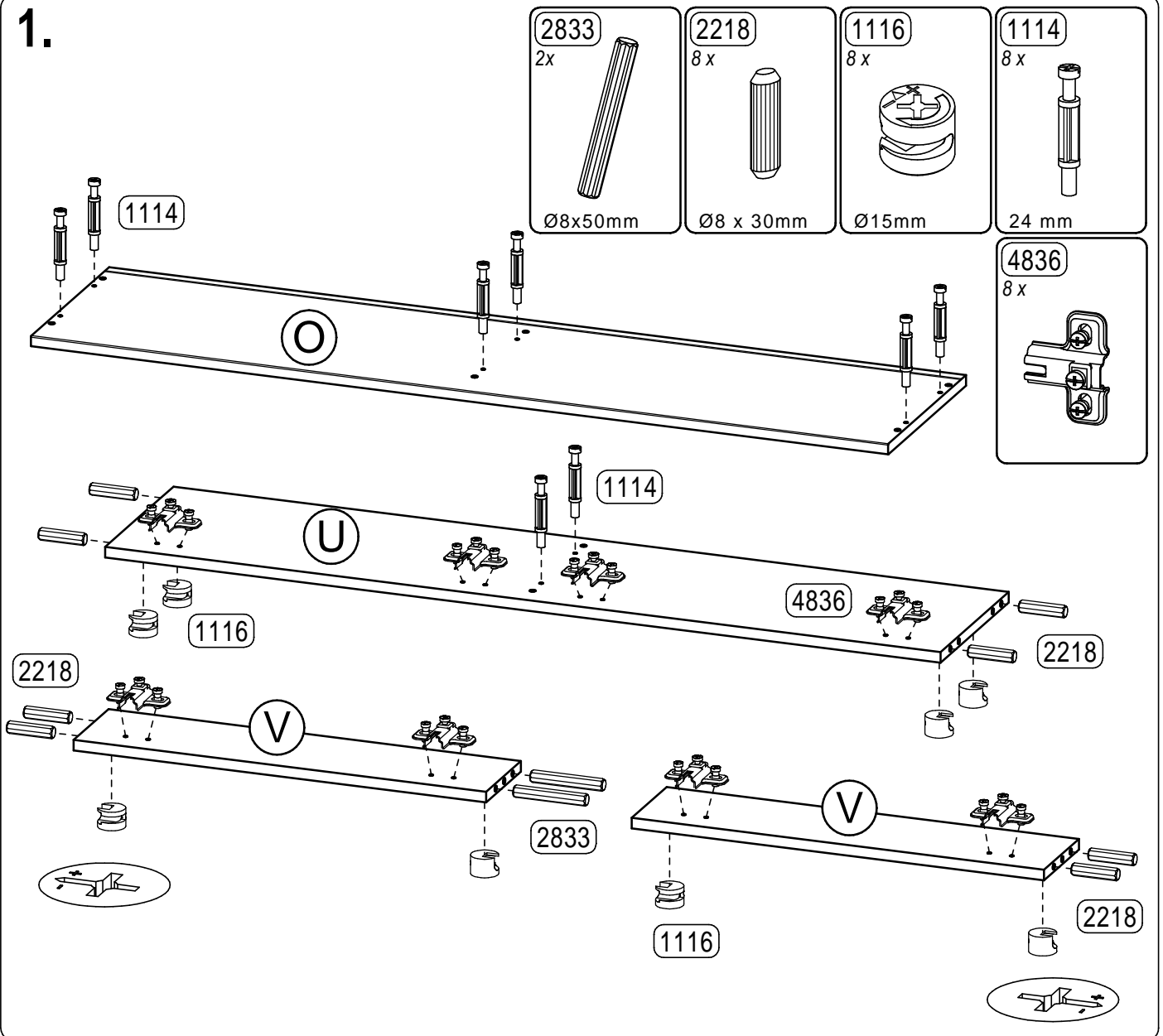

2.

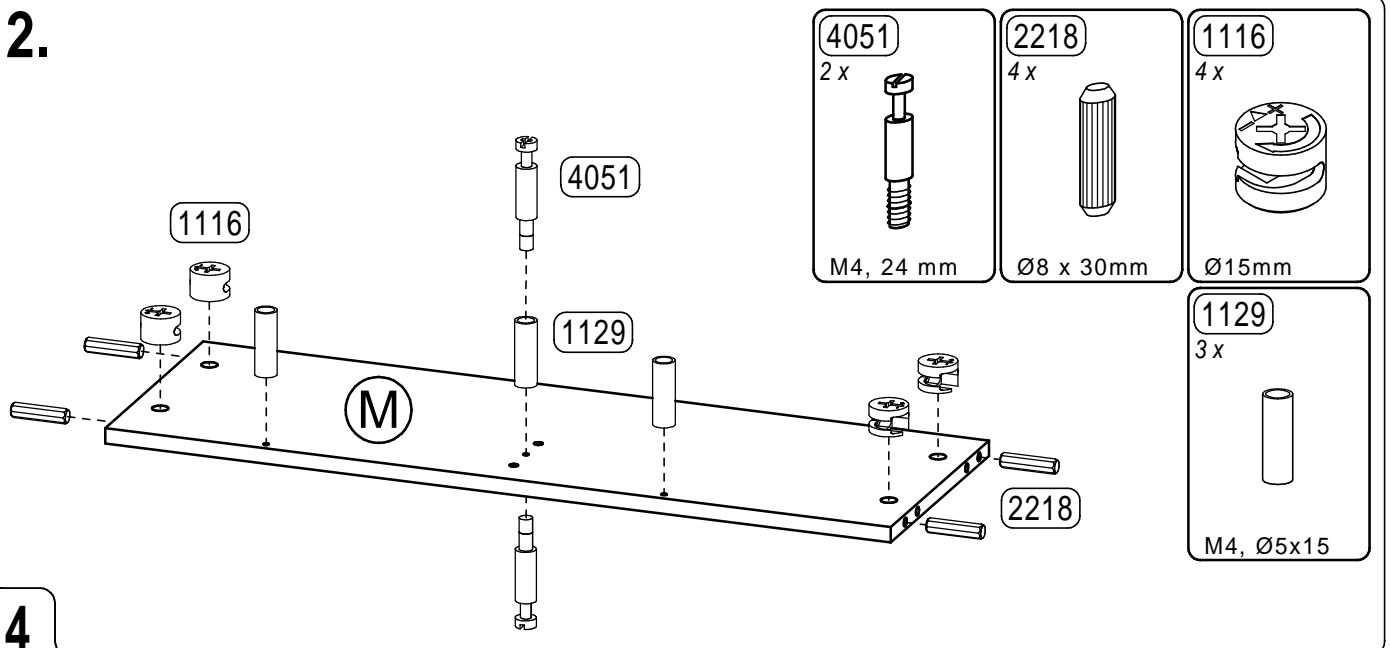

4

erstellt	geändert	geprüft
Datum: 06.07.09	Datum:	Datum: 08.07.09

Mod. 1178 **Montageschritte** - ordre de montage - assembly instructions

3.

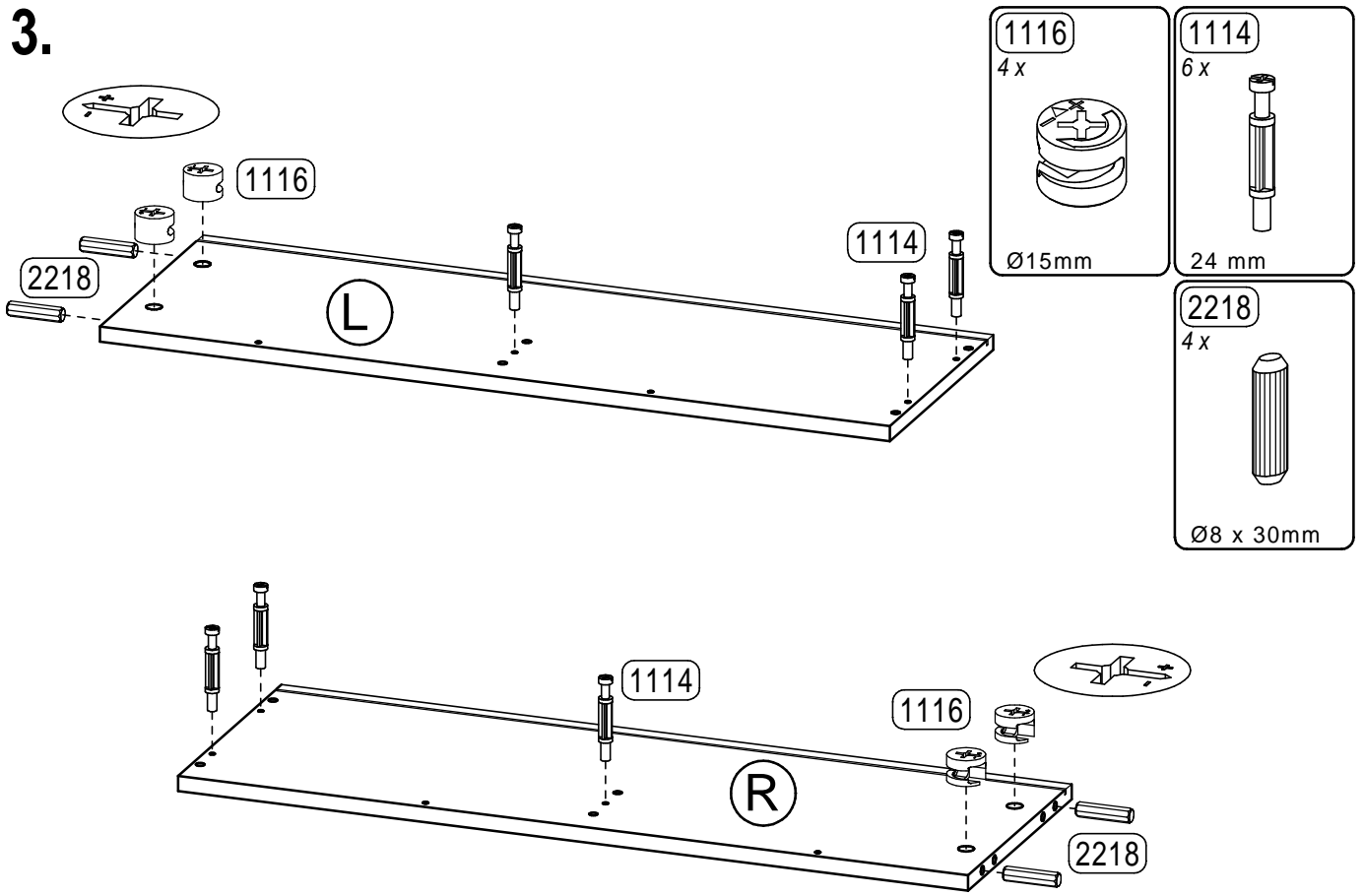

4.

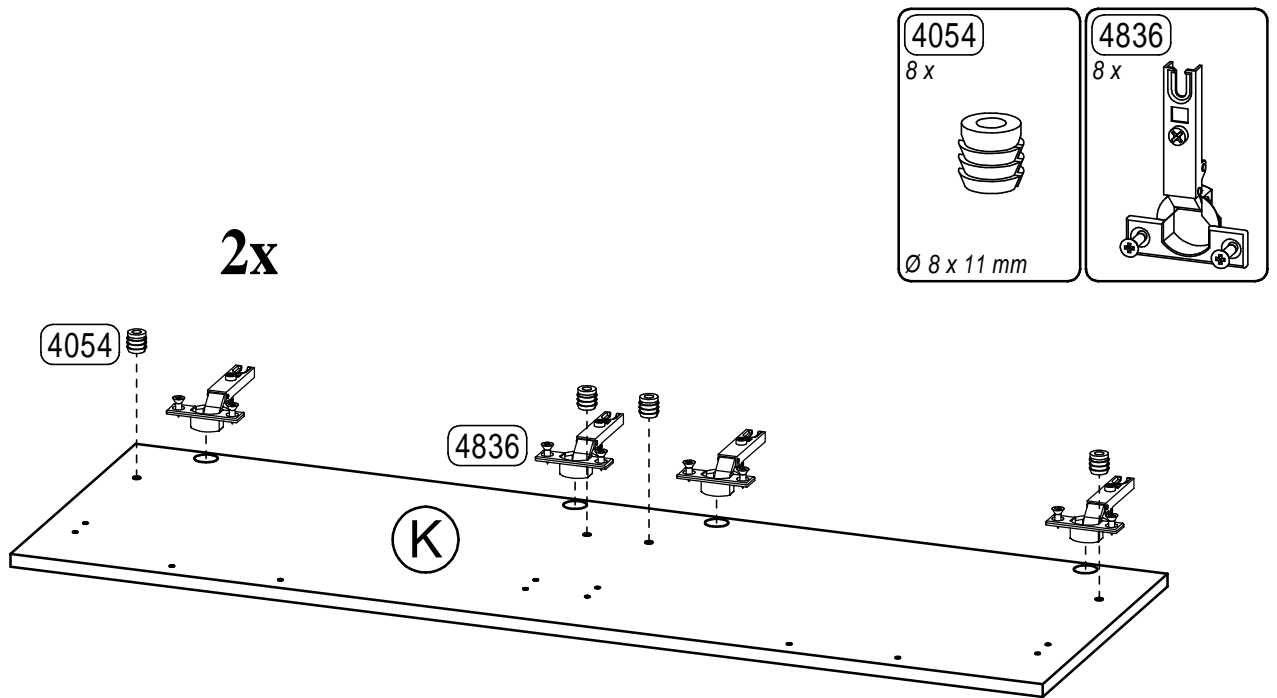

5

erstellt	geändert	geprüft
Datum: 06.07.09	Datum: 26.08.09	Datum: 28.08.09

5.

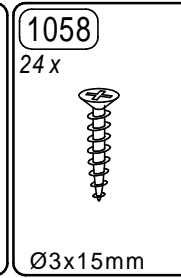
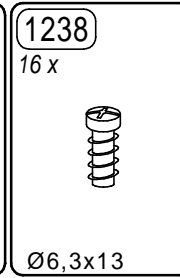
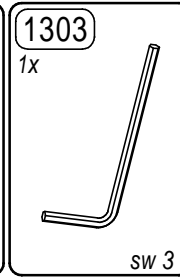
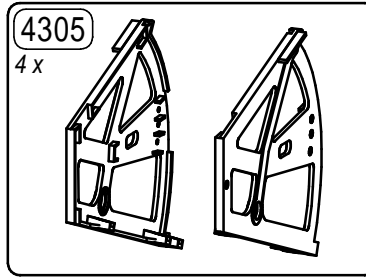

5.1

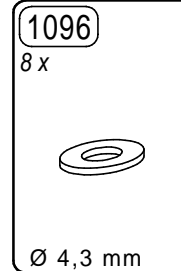
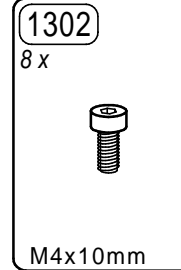
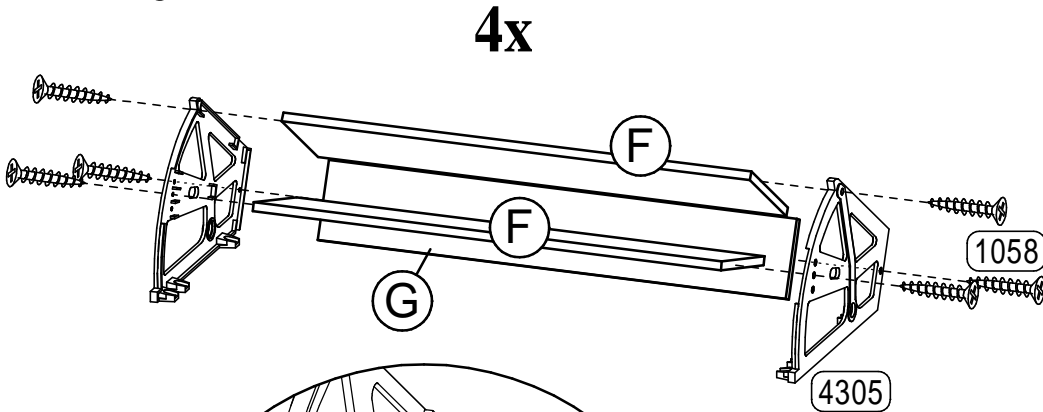

5.2

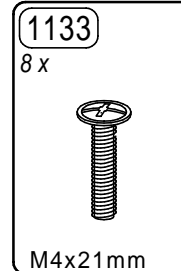
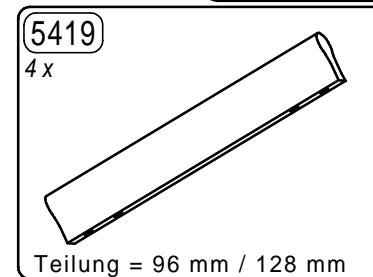
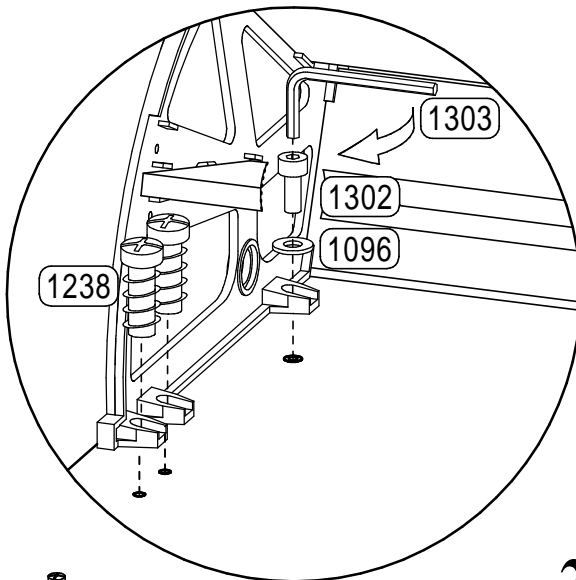

5.3

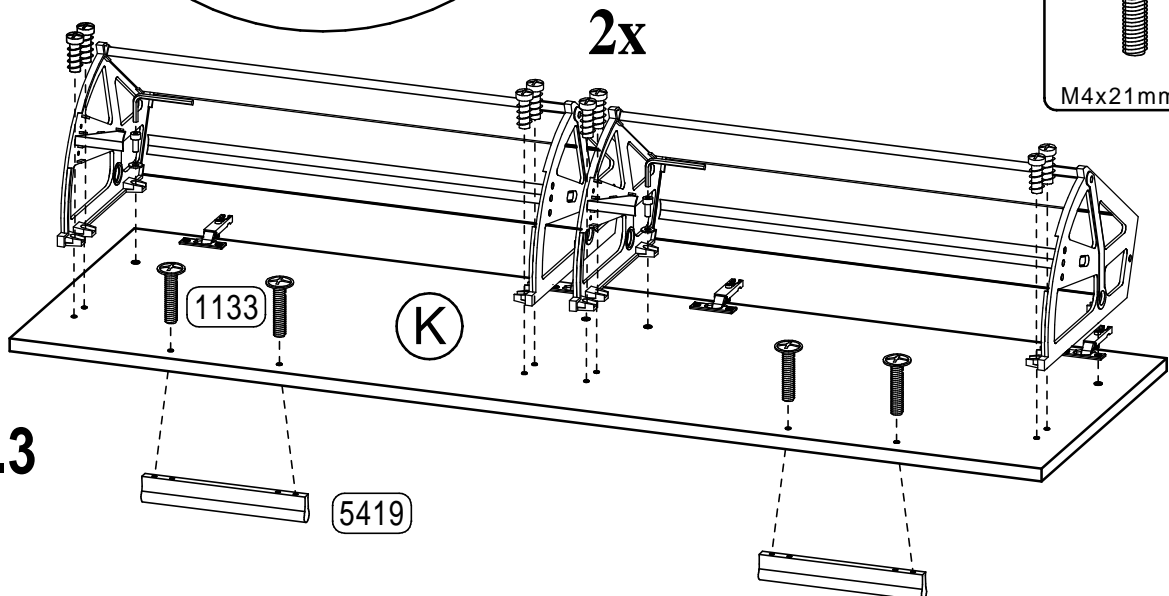

6

erstellt	geändert	geprüft
Datum: 06.07.09	Datum: 26.08.09	Datum: 28.08.09

6.

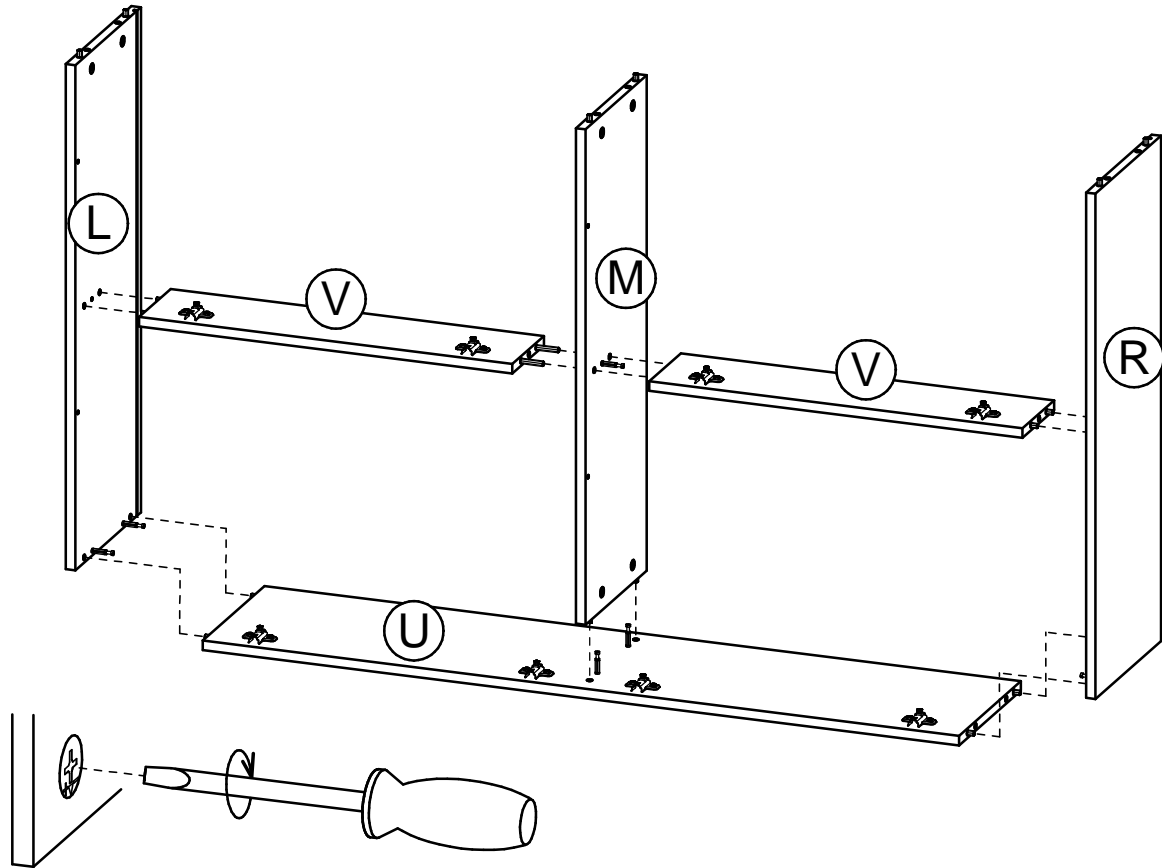

7.

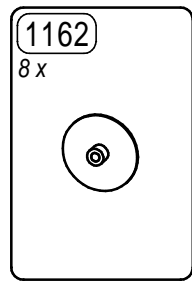
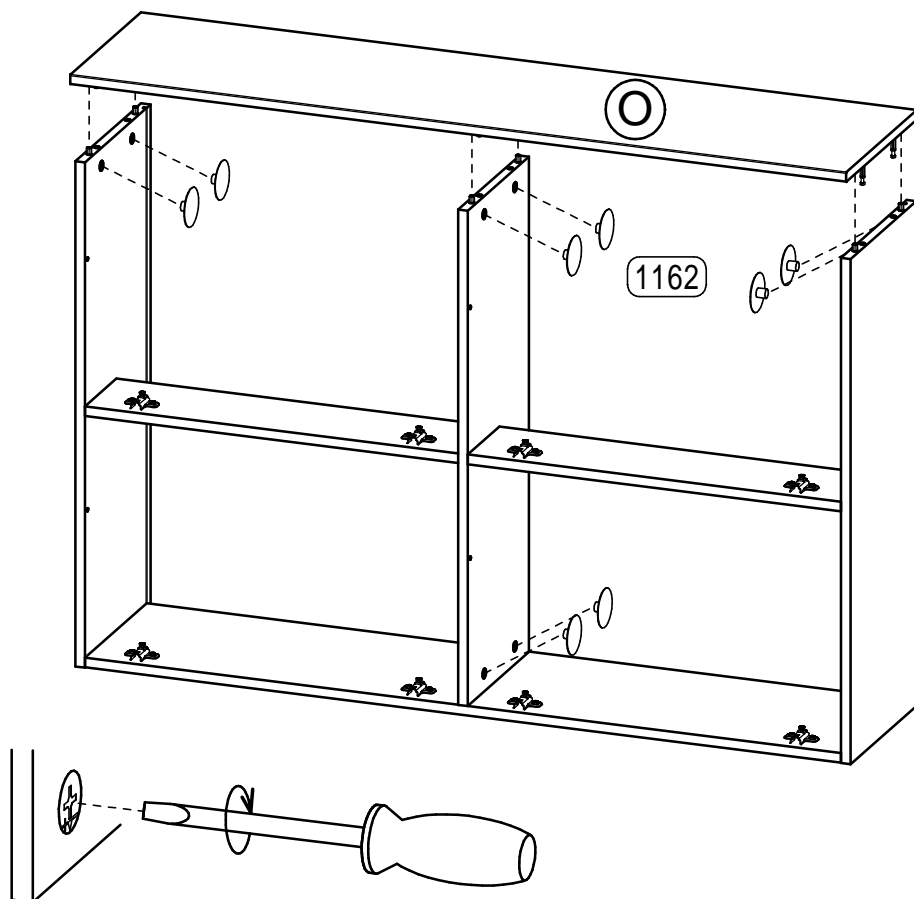

7

erstellt	geändert	geprüft
Datum: 06.07.09	Datum:	Datum: 08.07.09

8.

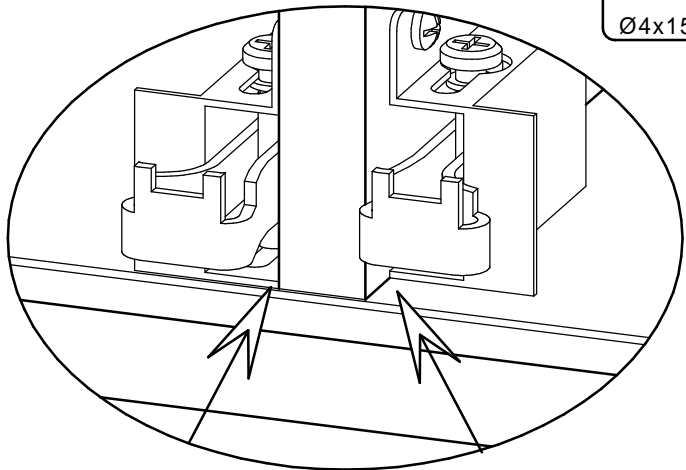
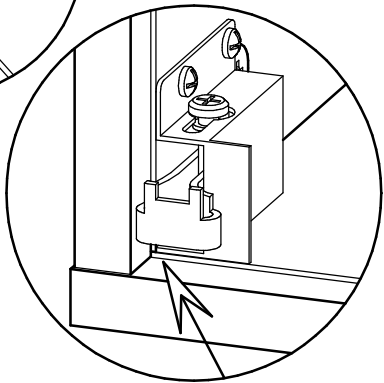
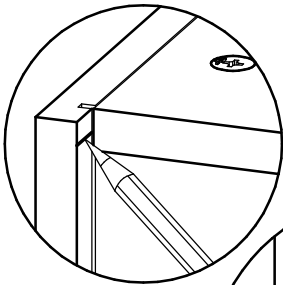
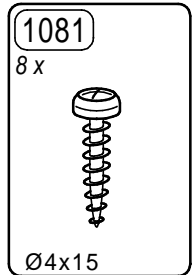
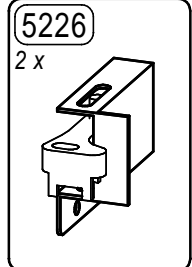
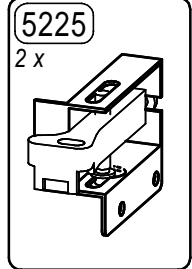
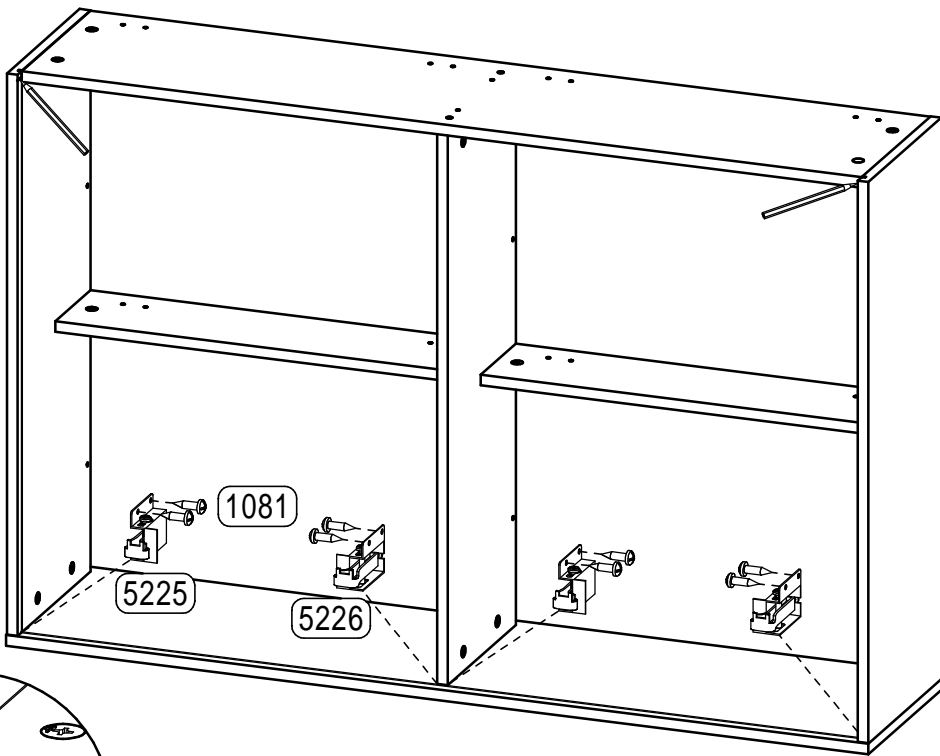

9.

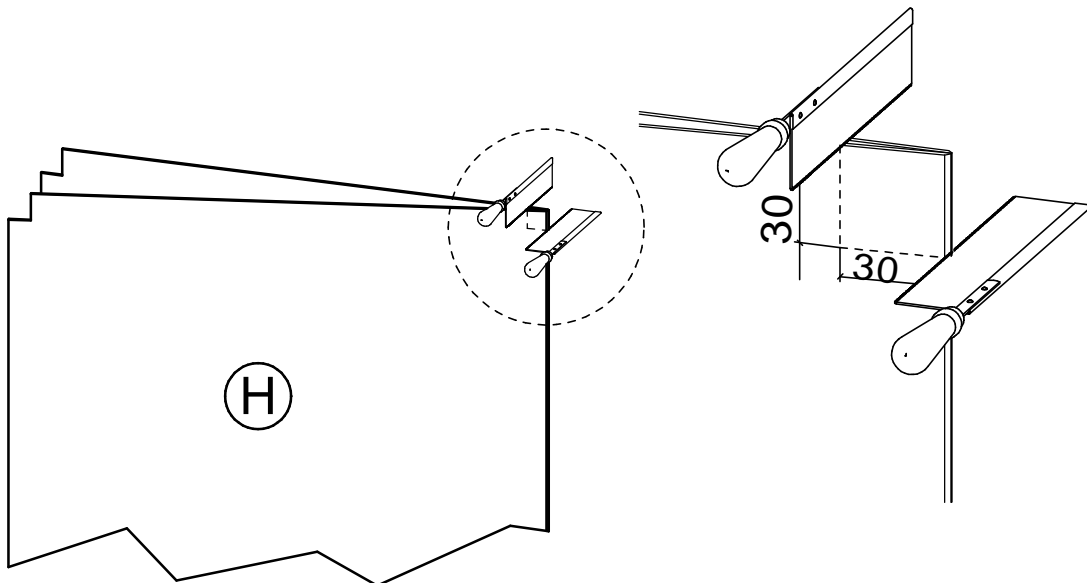

8

erstellt		geändert		geprüft	
Datum: 06.07.09		Datum:		Datum: 08.07.09	

10.

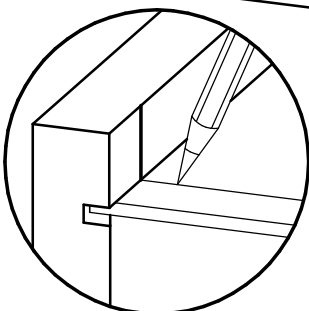
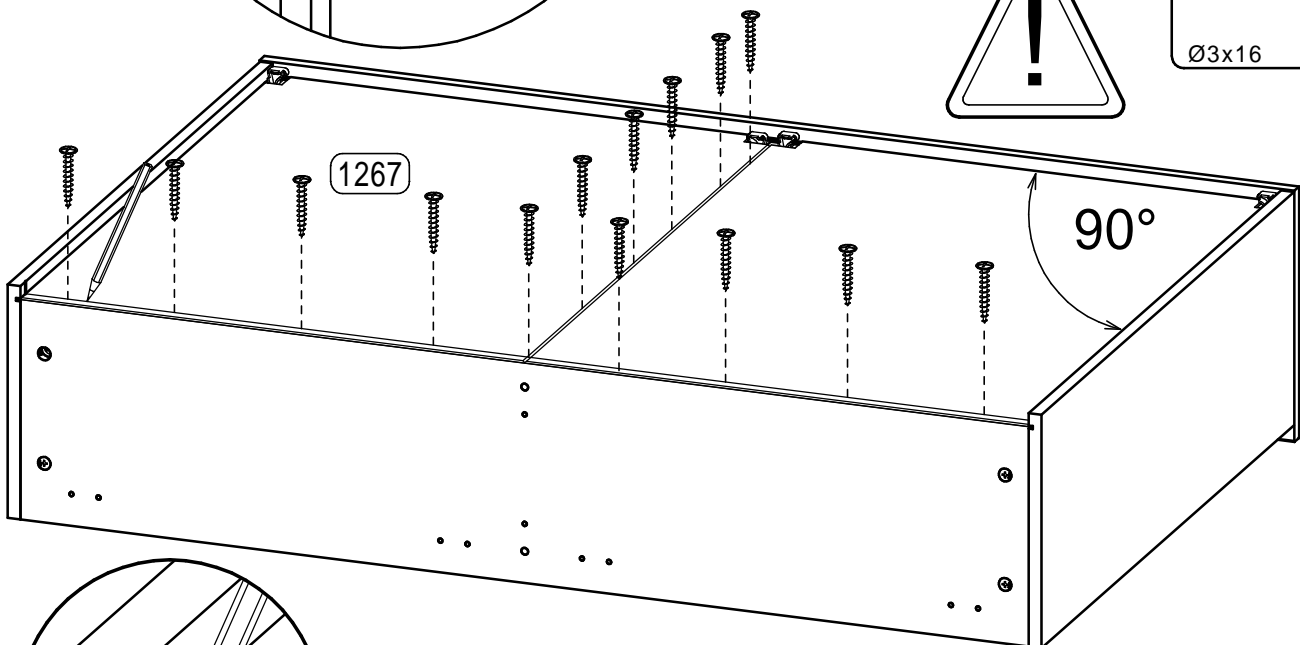
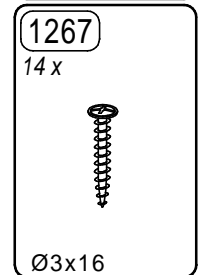
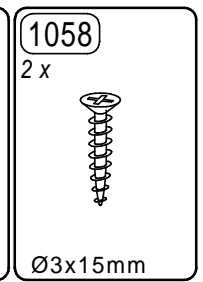
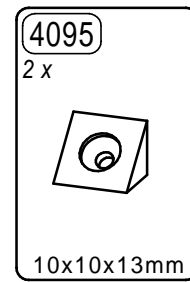
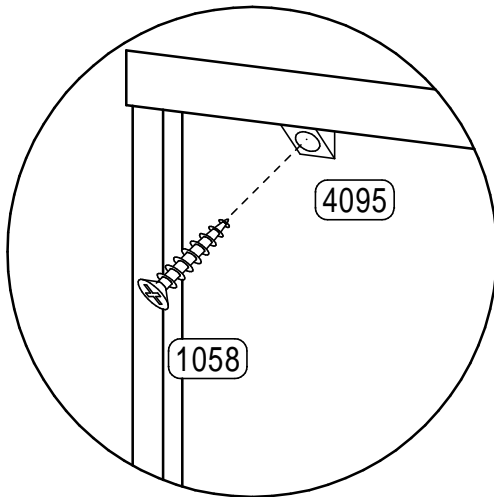
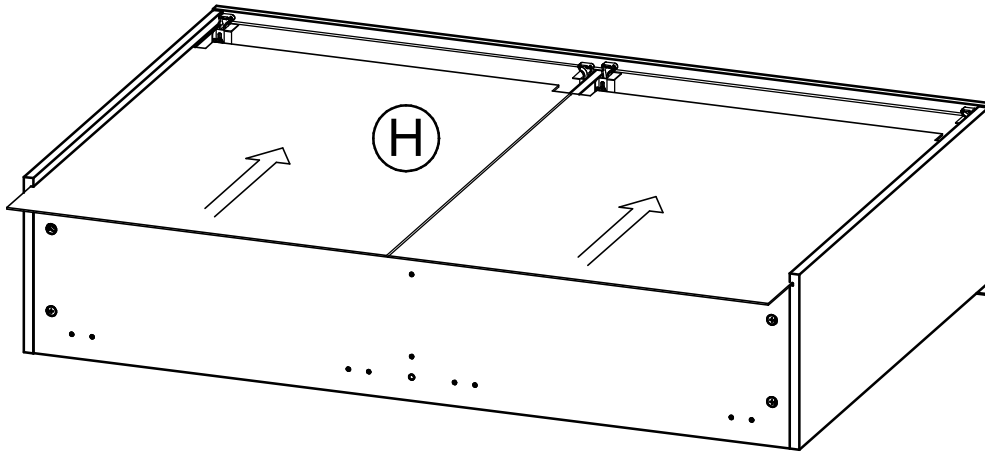

erstellt	geändert	geprüft
Datum: 06.07.09	Datum:	Datum: 08.07.09

Mod. 1178 **Montageschritte** - ordre de montage - assembly instructions

11.

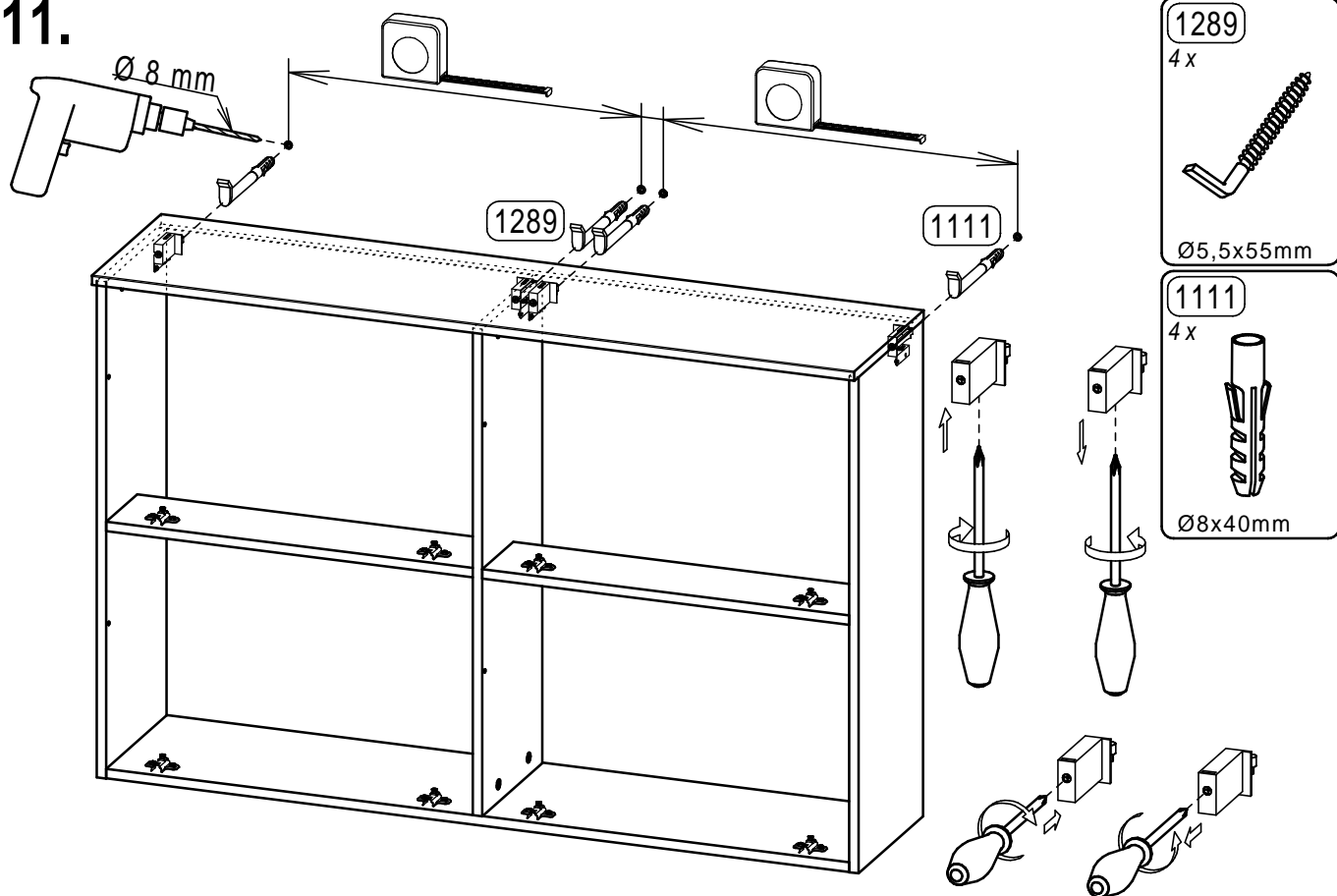

12.

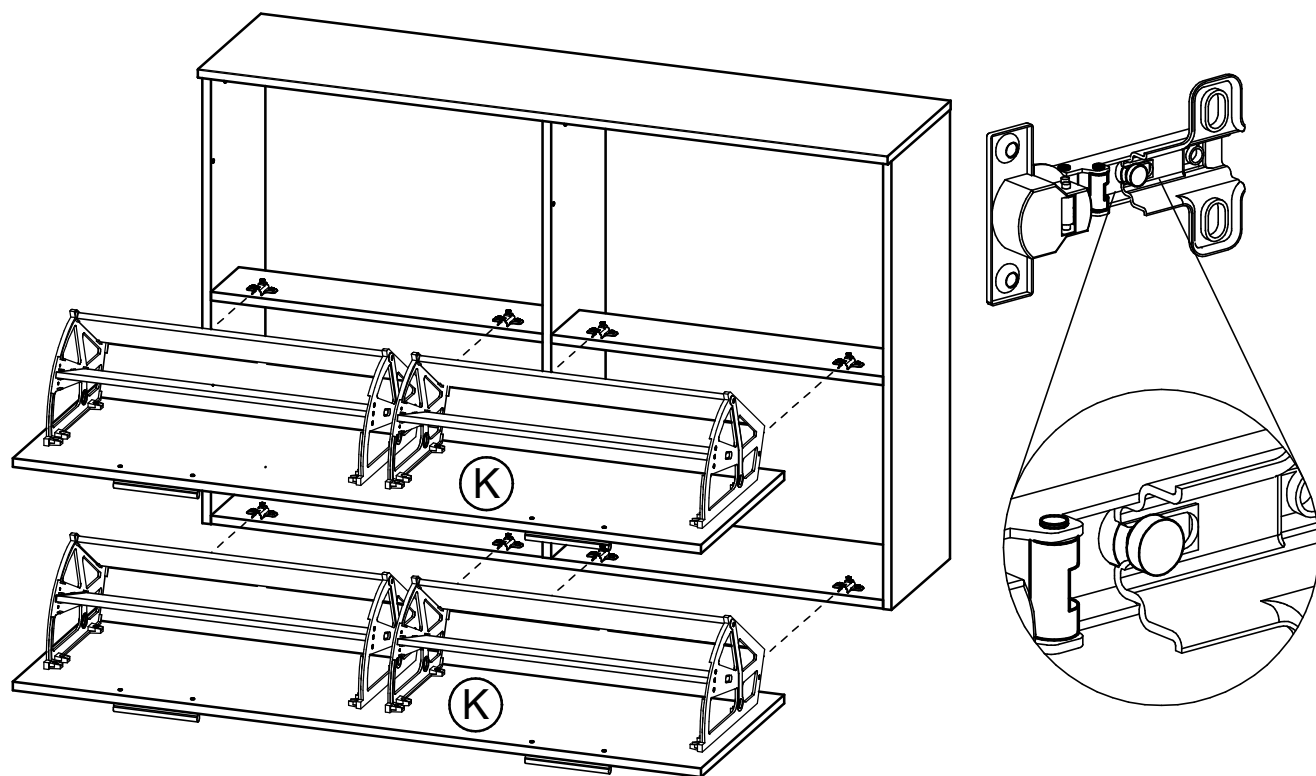

10

erstellt	geändert	geprüft
Datum: 06.07.09	Datum:	Datum: 08.07.09

13.

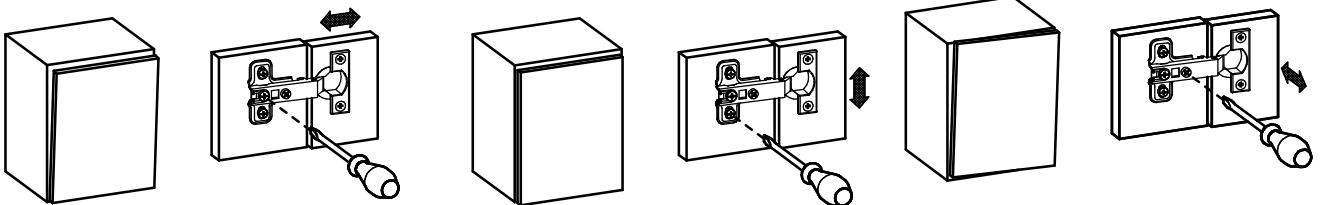
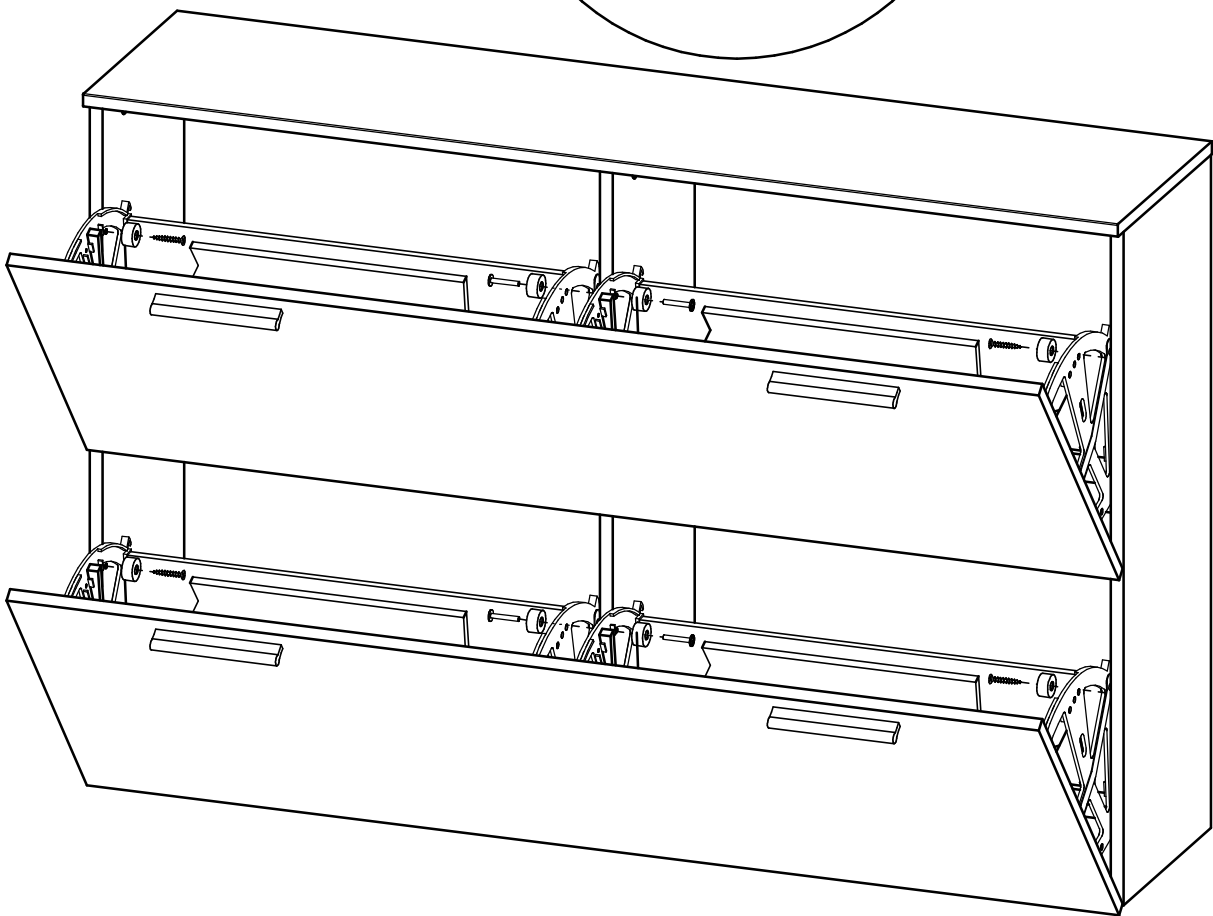
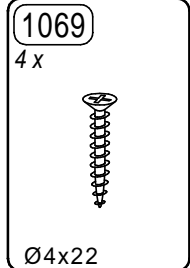
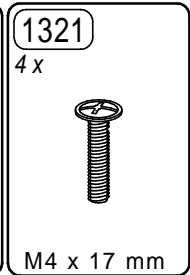
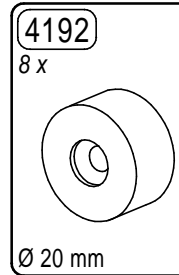
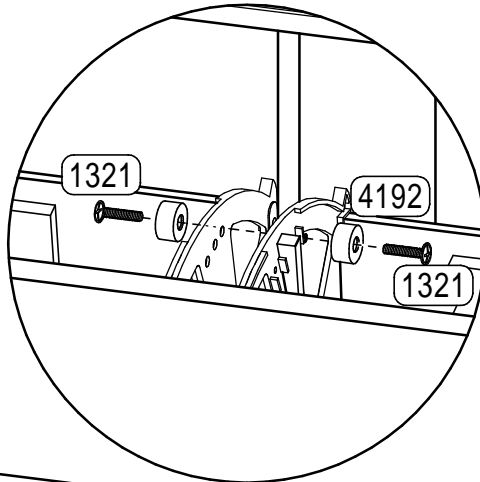
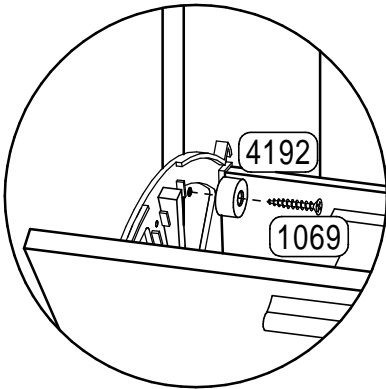

erstellt		geändert		geprüft	
Datum: 06.07.09		Datum:		Datum: 08.07.09	

Ersatzteil-Direkt Service

(nur für Deutschland - for germany only - seulement pour Allemagne)

Sehr geehrter Kunde,
sollte ein Möbelteil bzw. Beschlagteil fehlen oder beschädigt sein, senden Sie uns den Artikel bitte **nicht** zurück, sondern fordern Sie der Einfachheit halber Ersatz direkt bei **GERMANIA** an.
Tragen Sie Ihren Bedarf in die Tabelle ein und übermitteln Sie uns diese Seite per Post, per Fax, telefonisch oder per e-mail.
Bitte unbedingt die Modellnummer, Dekornummer (siehe Karton) und die entsprechende Teilebezeichnung (siehe Teilleiste) angeben.

Mod. Nr.:

Dekor-Nr.:

Möbelteile			Beschlagteile				
Teil	beschädigt* Z	fehlt* X	Anzahl	Teil	beschädigt* Z	fehlt* X	Anzahl
			1	9137			2

* beschädigt oder fehlt bitte ankreuzen

Absender nicht vergessen :

Name:	Strasse u. Nr.:		
PLZ:	Ort :		
Tel.:	Fax:	e-mail:	

Unsere Hotline :

Tel. 05252 84939

und 05252 84962

Fax: 05252 84936

e-mail : service@mygermania.com

GERMANIA - Service - Postfach 1160 D 33189 Schlangen

Sicherheitshinweise

Safety instructions

GERMANIA

the furniture factory

Indications de sécurité

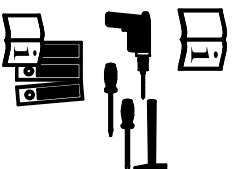

- 1.) Montageanleitung aufmerksam durchlesen
Please read assembly instruction carefully
Prétre de bien lire la notice de montage du début à la fin
- 2.) Montage nach Montageanleitung durchführen
Please follow the assembly instruction step by step
Bien suivre le sens du montage indiqué sur la notice
- 3.) Montageanleitung aufbewahren
Please save the assembly instruction
Bien conserver la notice de montage



ACHTUNG!

Beschlagbeutel und Beschlagteile
von Säuglingen und Kindern fernhalten

ATTENTION!

To avoid suffocation keep plastic bag away from children
Contains small parts which may be a choking hazard

ATTENTION!

Toutes les pièces détachées livrées dans le colis être mis
hors de portée des bébés des et enfants

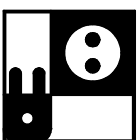
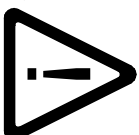

Netzanschluss (230V) nur von einem Fachmann ausführen lassen.
Sanitäranschluss nur von einem Fachmann ausführen lassen.
Mains connection (230V) has to be done by an expert.
Sanitary installation has to be done by an expert.
L'électricité (230V) uniquement à faire par un électricien.
Installation sanitaire à faire par un spécialiste.

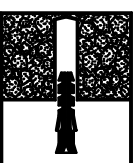
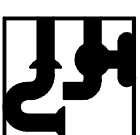

Beiliegendes Befestigungsmaterial eignet sich nur für Massivwände.
Für andere Wände müssen Spezialdübel verwendet werden.
Die Festigkeit ist zu Prüfen.
The attached fixing materials is only suitable for solid walls.
For other Types of walls special dowels have to be used.
The firmness have to be checked.
Le matériel de fixation ci-joint est exclusivement prévu pour des murs
pleins(une fixation spéciale est nécessaire pour cloisons placo,..).
La fermeté est à examiner.

Beiliegende Wandbefestigungen dienen als Kipperschutz,
unbedingt anbringen!

The attached wall fixing is necessary to avoid tipping
and must be fixed!

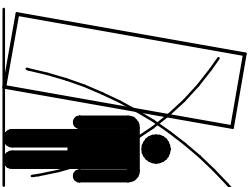

Les fixations prévues dans le colis
préviennent contre le renversement du
meuble. Il faut impérativement fixer le
meuble au mur, afin d'éviter tout incident!

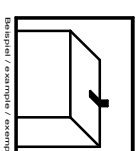

Für Schäden, die durch unsachgemäße Montage entstanden sind, übernehmen wir keine Haftung
For the damages, which have originated from improper assembly, we take over no liability.
Pour les dommages qui sont nés par le montage incorrect, nous ne prenons en charge aucune responsabilité.