

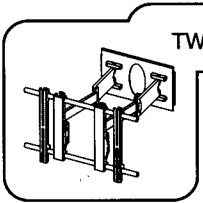

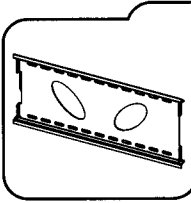

Model: TWM 9, TWM 10

Component List

Component	Description	Qty	Component	Description	Qty
	TWM 9,10 Bracket (A)	1		Wall Bracket (B)	1
	Wall fixing Screw (C)	8		Wall Plug (D)	8
	Screw 1/4 x 1 for TWM9 (E)	3		Screw 1/4 x 1 for TWM10 (F)	4
	TV Mounting Screws including M4 M5 M6 M8 (G)	32		Assorted Washers (H)	12
	Assorted Spacers (I)	8		Angled Spacers (J)	8

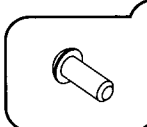
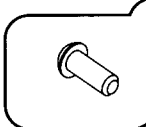
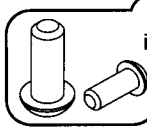
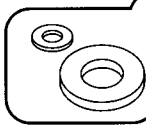
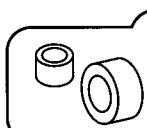
MODEL: TWM 9, TWM 10

Plasma/LCD Television Bracket

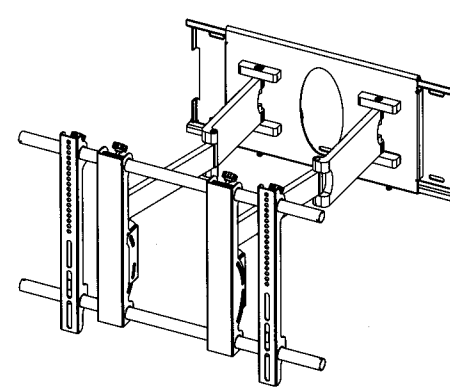

TWM 9
Screen Weight 50kg - Screen Size 32-42"

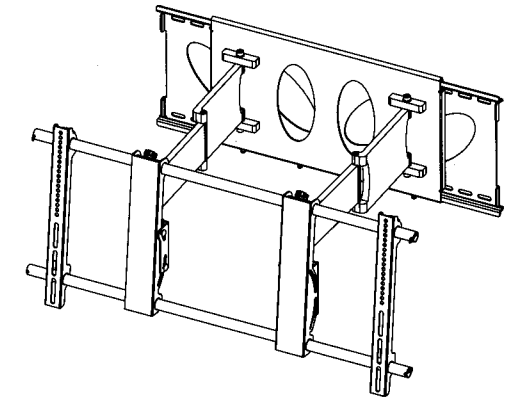

TWM 10
Screen Weight 60kg - Screen Size 32-65"

Thank you for purchasing this LCD/Plasma TV Support System.
Every effort is made to make sure these instructions are correct.
In an effort to constantly improve our products minor changes may occur.
Important : Do not exceed the maximum screen size or weight stated for your model.

1 - Fix The Wall Mounting Bracket To The Wall.

Fixing To Brick/Block Walls:

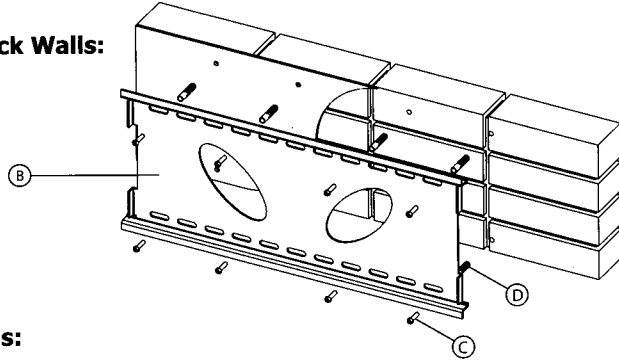

Fixing To Stud Walls:

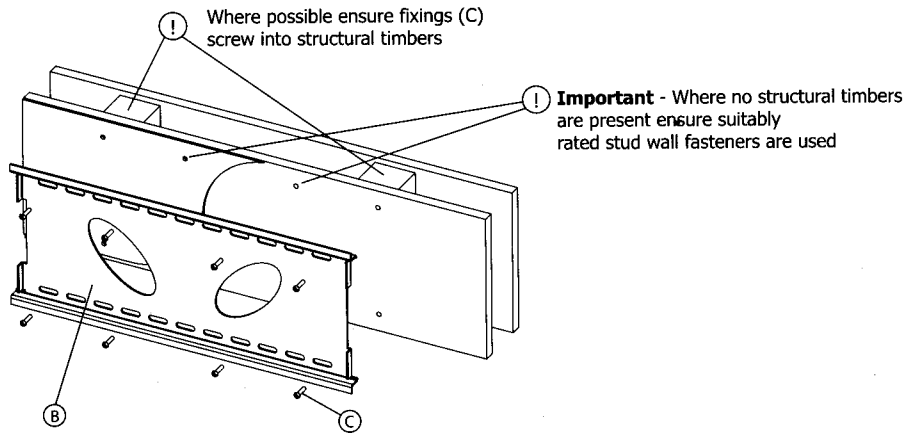

2 - Secure The Screen Mounting Bracket to Screen.

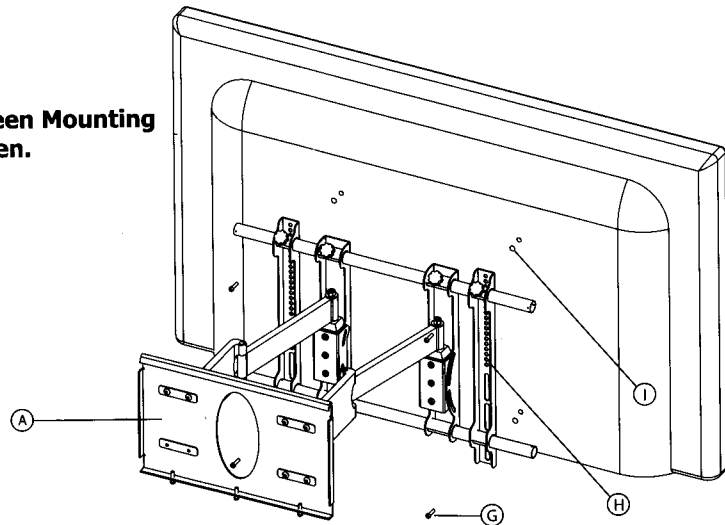

3 - Secure Screen Mounting Bracket To Wall.

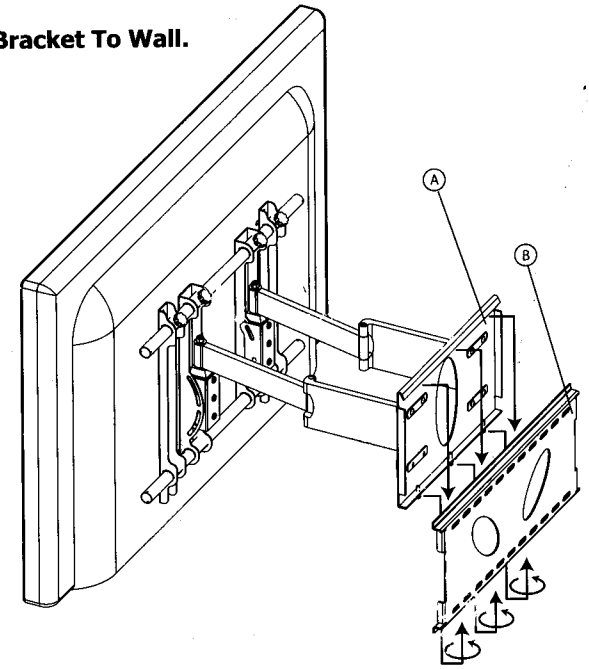

4 - Detailed View of Securing the Screen Mounting Bracket To Wall.

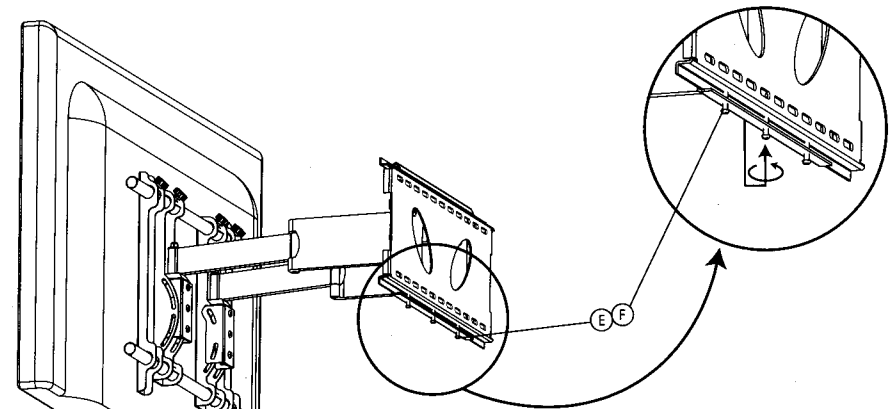

If you are in any doubt about the installation of this Plasma/LCD Mounting system please contact a professional installer.