

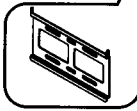

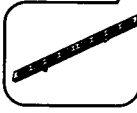

Model: TLCD - 7  
Component List

Component	Description	Qty
	Wall Plate (A)	1
	Mounting Bracket (B)	2
	Screw M5 * 20 (C)	2
	Screw M4 * 12 (D)	4
	Screw M5 * 12 (E)	4
	Rawl Plug (F)	6
	Screw M5.5 * 41.5 (G)	6

MODEL: TLCD - 7  
Wall Support for LCD Screens

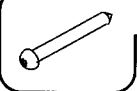
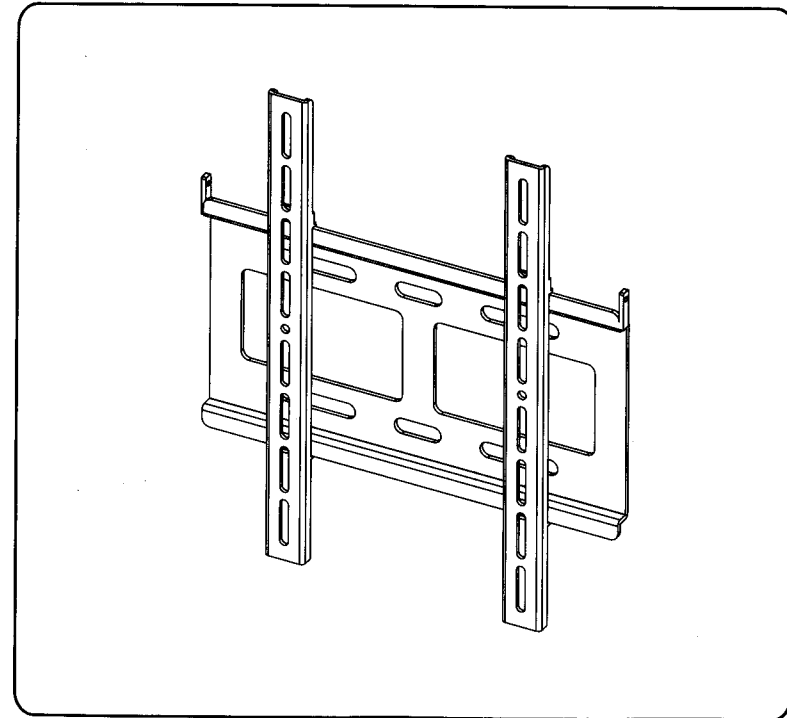

**Important Assembly Advice**

It is recommended that two people should undertake any lifting/moving of plasma screens.

Every effort is made to make sure these instructions are correct, in an effort to constantly improve our products minor changes may occur. E, O & E

### Step 1

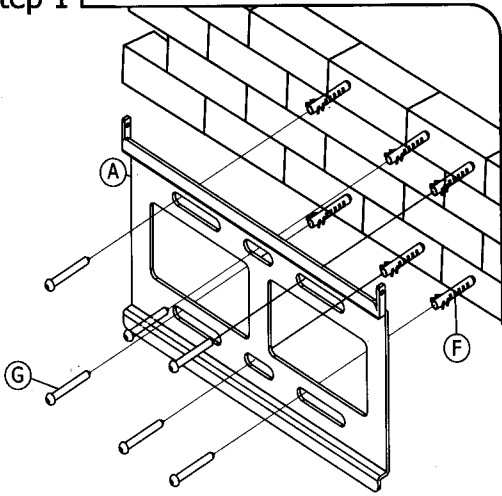

For Brick Walls use the following method as illustrated, for affixing wall plate. Drill 6 holes into the wall by using Wall Plate (A) as a template. Insert Rawl Plugs (F) into the holes, then use M5.5 \* 41.5 Screws (G) to secure the Wall Plate (A) to the wall.

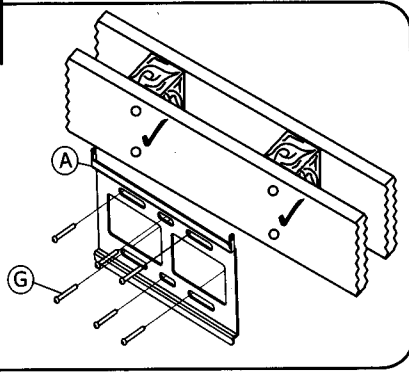

For Stud Walls, screw straight into wall with Screw M5.5 \* 41.5 (G) making sure at least one line of fixings is attached securely to a wooden baton.

### Step 2

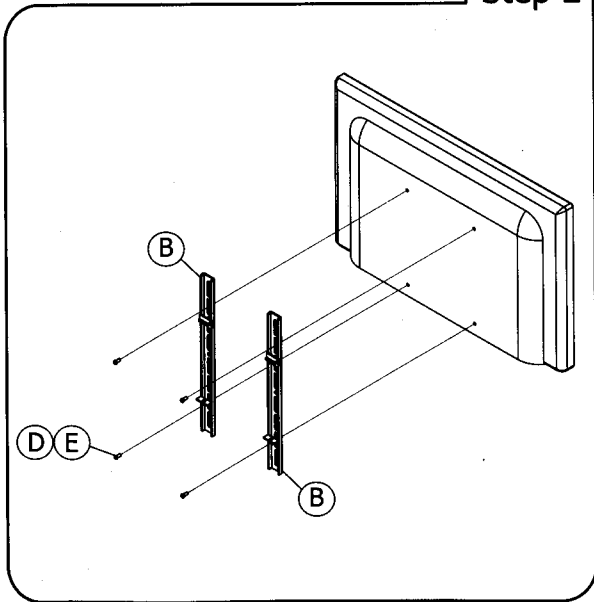

Take both Mounting Brackets (B) and using either the M4 \* 12 Screw (D) or M5 \* 12 Screw (E) provided, fix them to the rear of the screen.

### Step 3

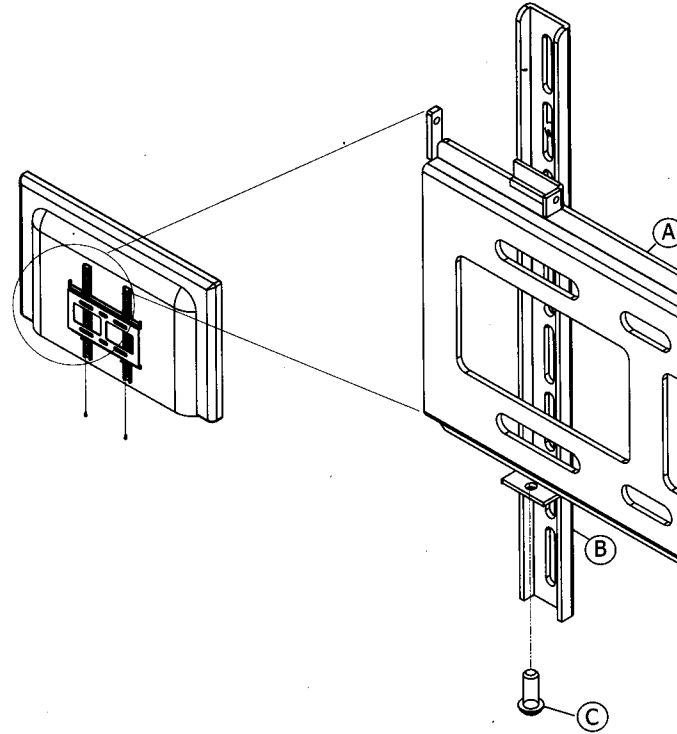

Make sure the screen is supported at all times as you lift the screen up and hook the affixed Mounting Arms (B) over the Wall Plates (A) top rail. Once in the correct position take M5 \* 20 Screw (C) and secure screen to Wall Plate (A) by screwing it upwards into the location hole on the underside of the Mounting Arm (B). Tighten until screw reaches underside face of Wall Plate (A) and screen feels secure.