

A	B	C (mm)		D
7	S236-1084	693	400	1/1
8	S236-1085	693	400	1/1
9	S236-2067	975	400	1/1
10	S236-2068	975	400	1/1
11	S236-4010	942	70	1/1
12	S236-9332	952	703	1/1
13	WSP-9056	912	358	1/1
14	WSP-9063	912	308	1/1
15	WSQ4-503	300	140	1/1
16	WSQ4-504	300	140	1/1
17	WSQ4-505	350	140	1/1
18	WSQ4-506	350	140	1/1
19	WTQ-5131	902	127	1/1

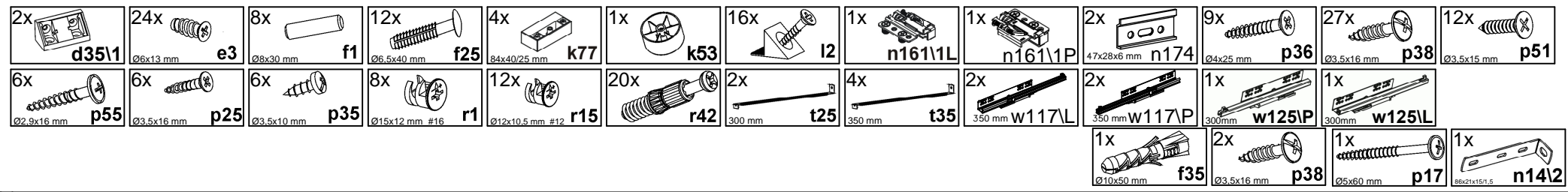

## WERSJA UCHWYT 1

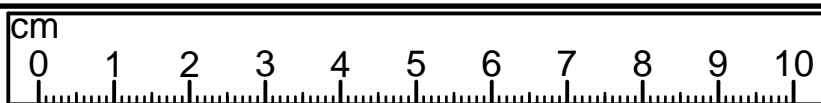
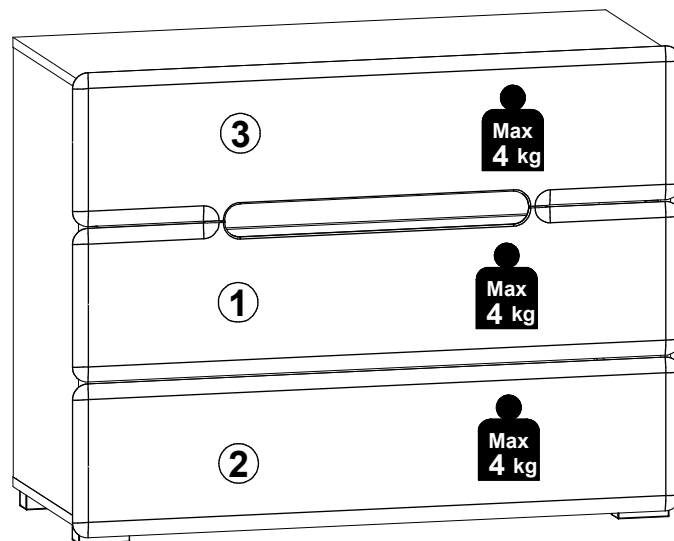

A	B	C (mm)		D
1	S236-0061	248	1000	1/1
2	S236-0062	248	1000	1/1
3	S236-0063	248	1000	1/1

## WERSJA UCHWYT 2

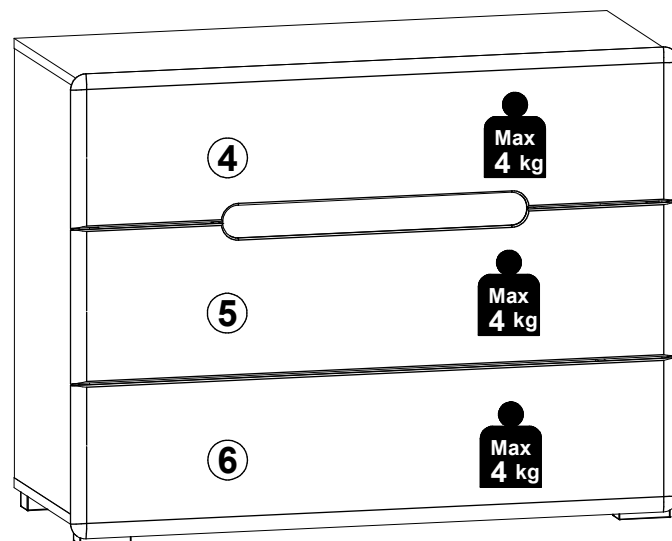

A	B	C (mm)		D
4	S236-0064	248	1000	1/1
5	S236-0065	248	1000	1/1
6	S236-0066	248	1000	1/1

1

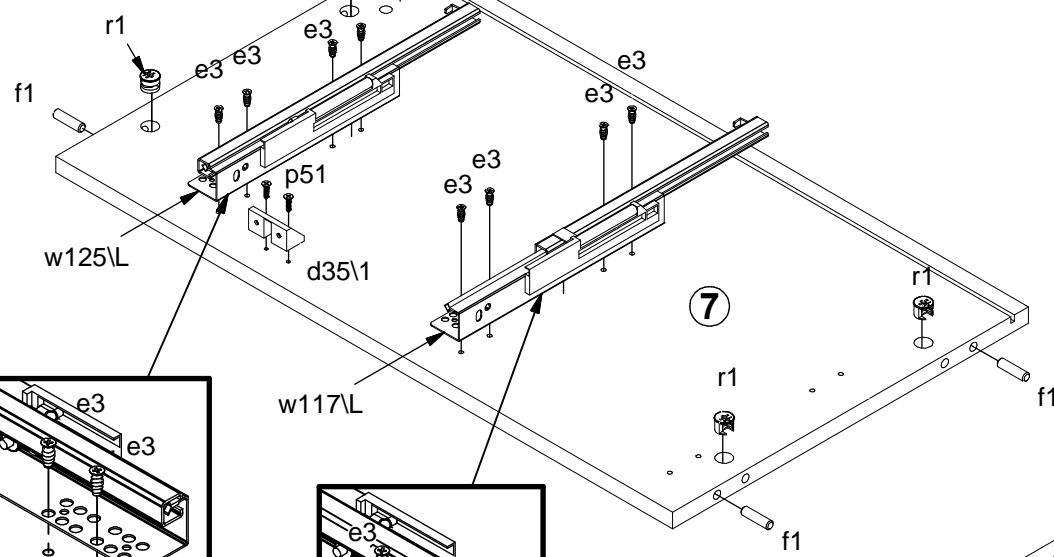
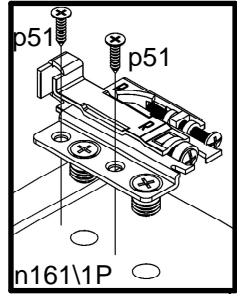
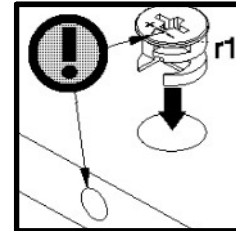
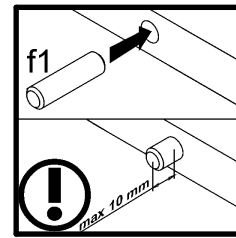
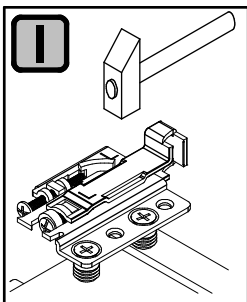
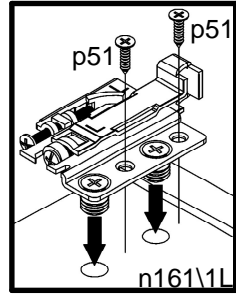

7

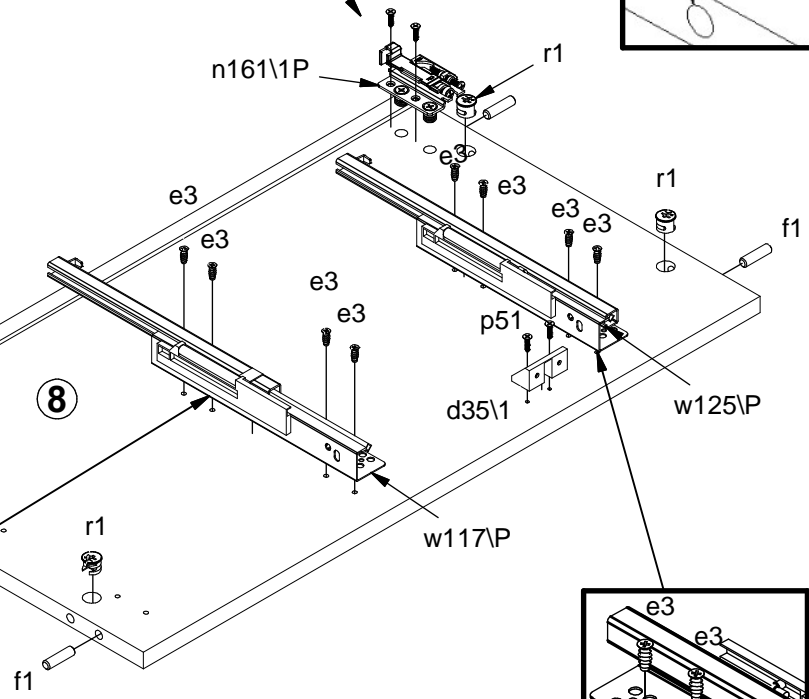
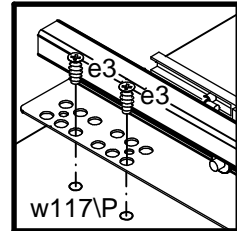
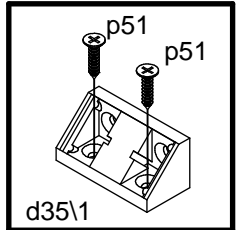
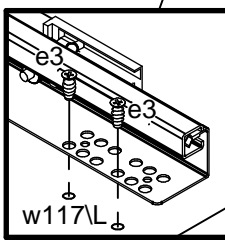
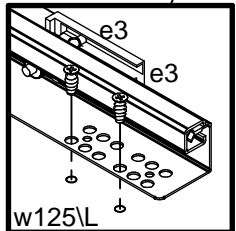

8

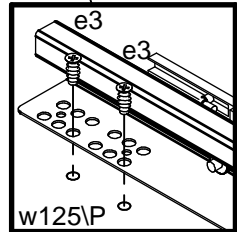

2

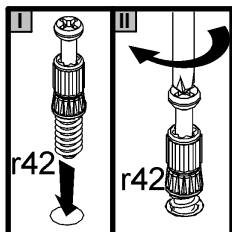
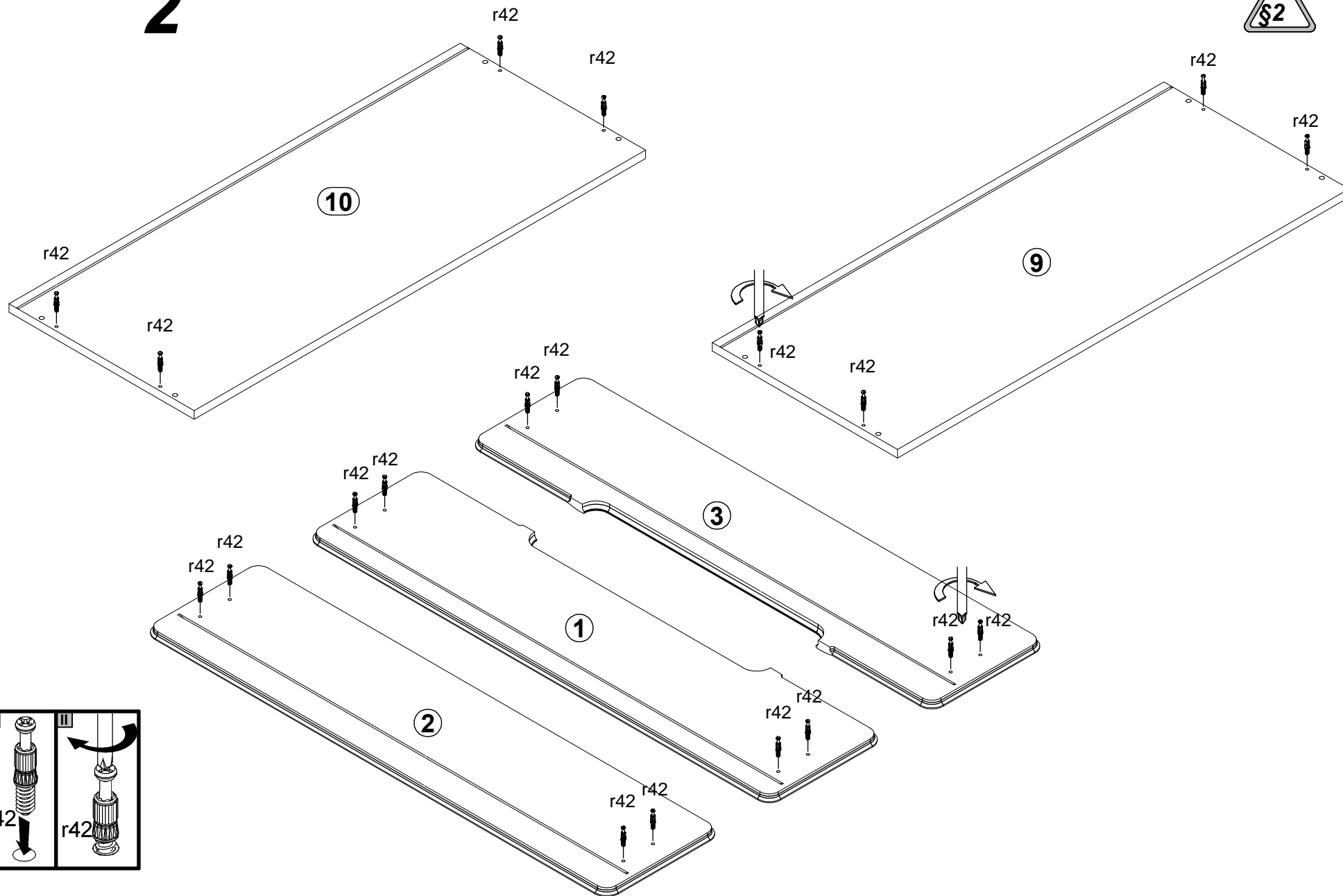



3

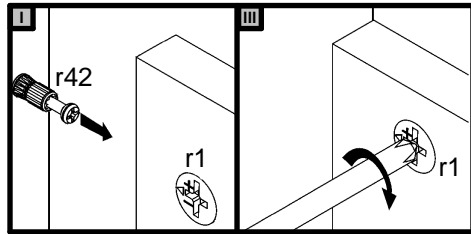

5

4

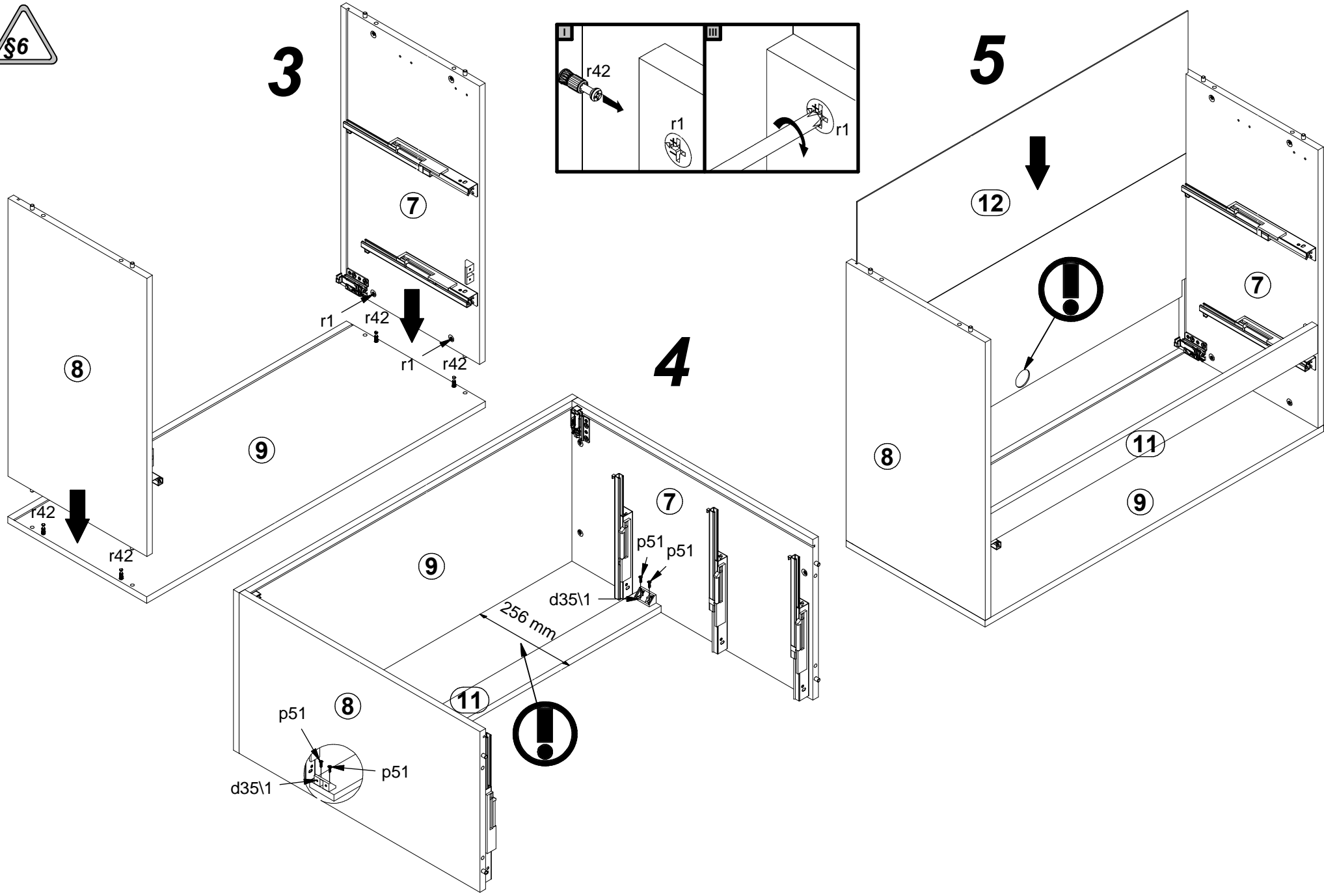

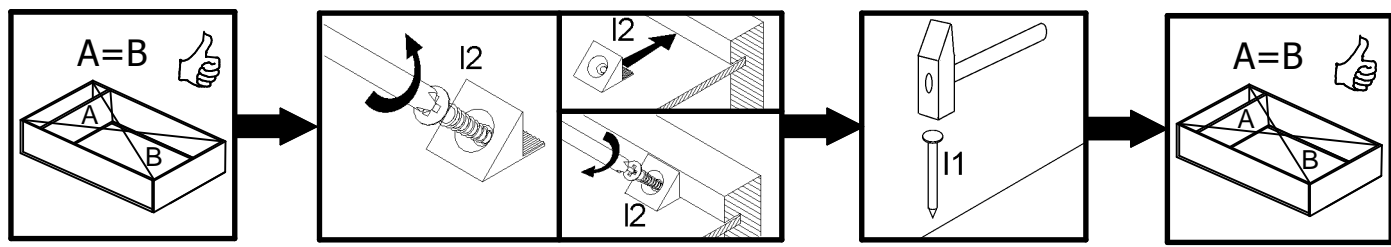

6

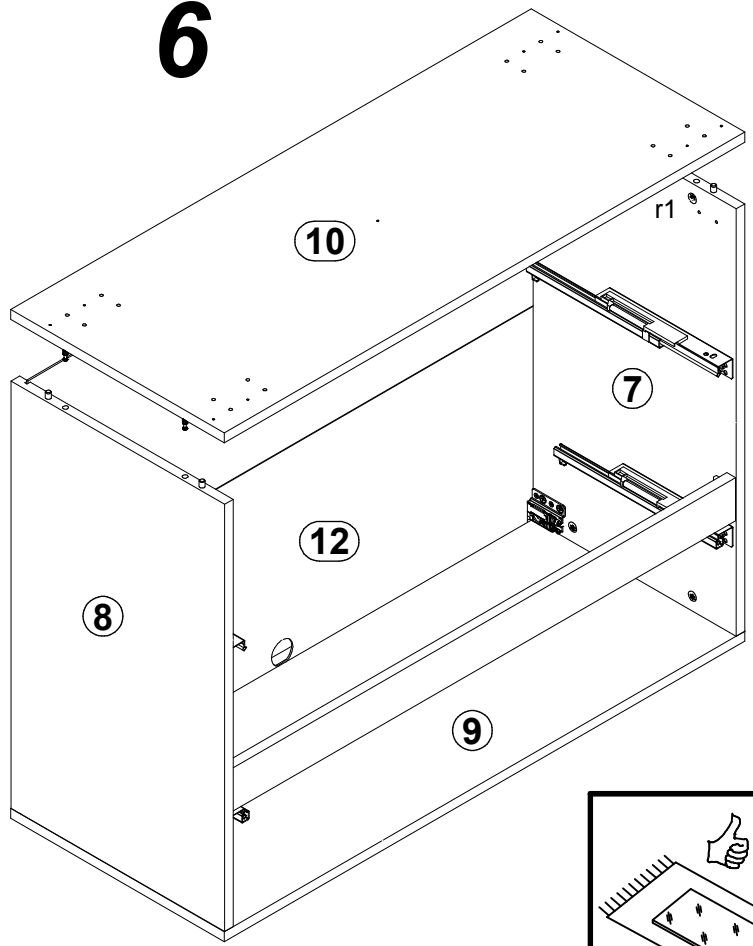

7

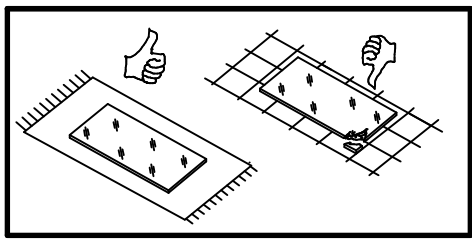
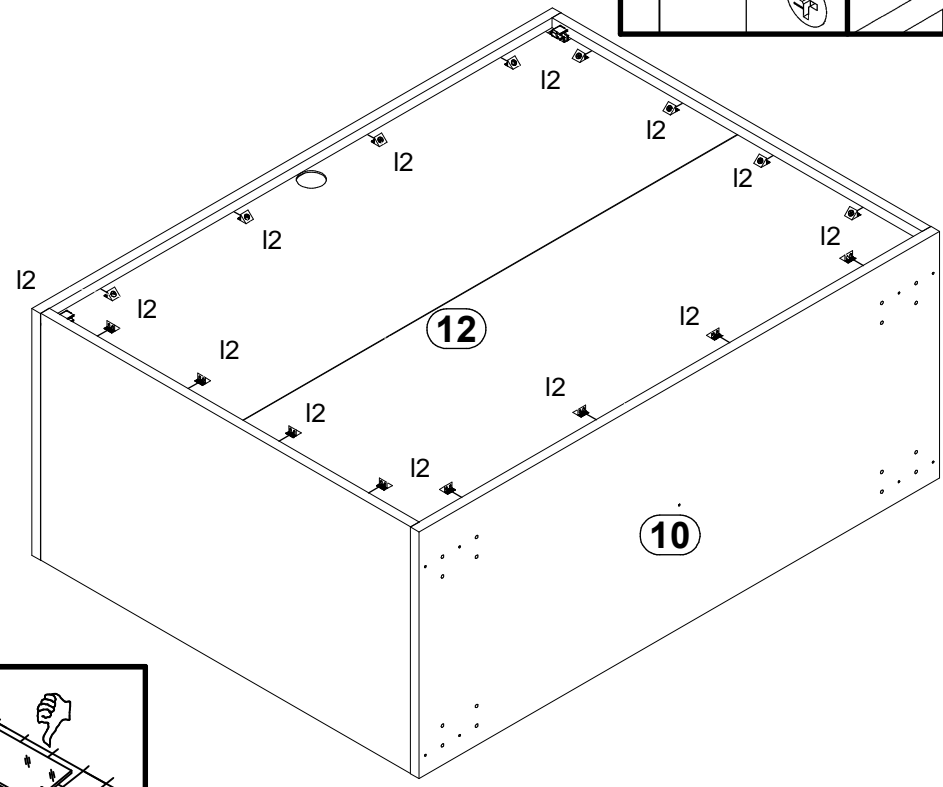

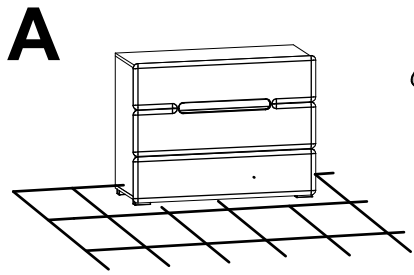

8

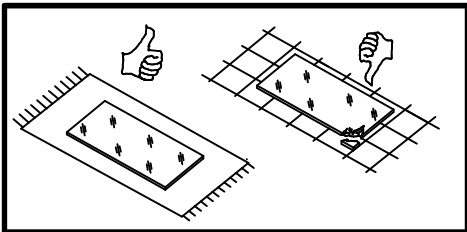
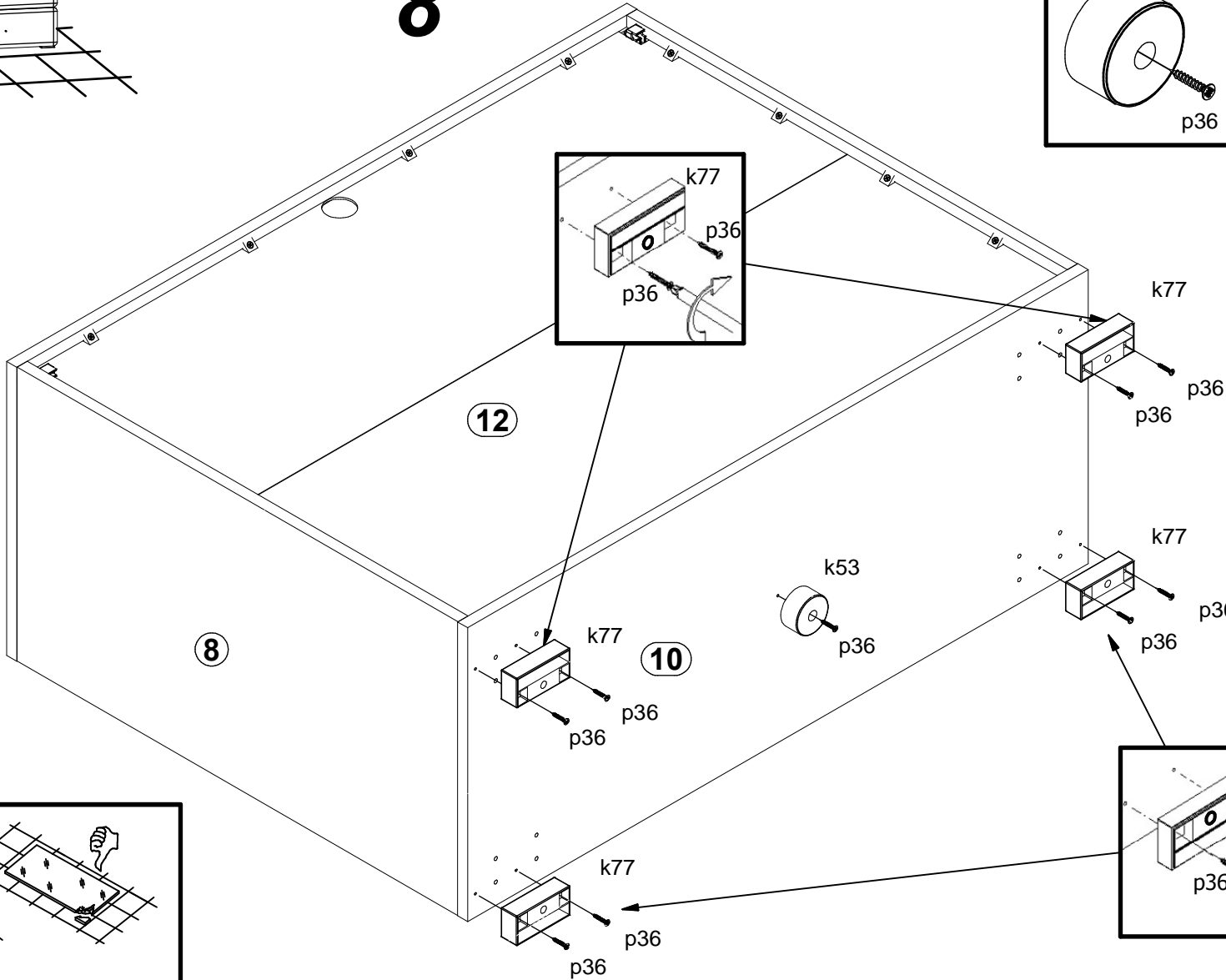
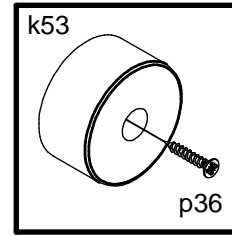



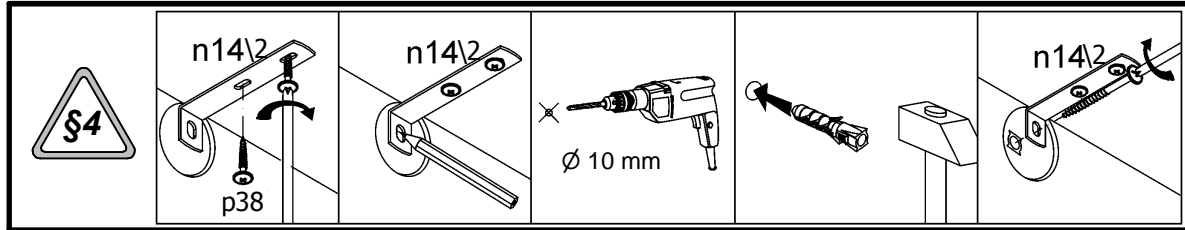
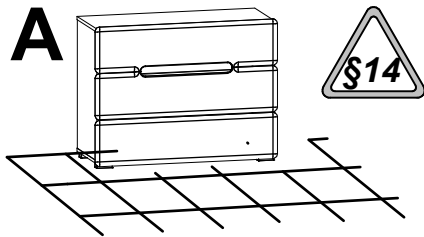

9

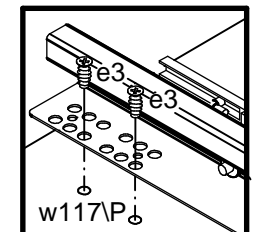
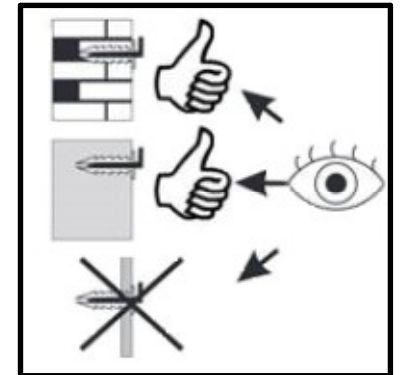
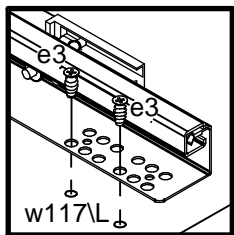
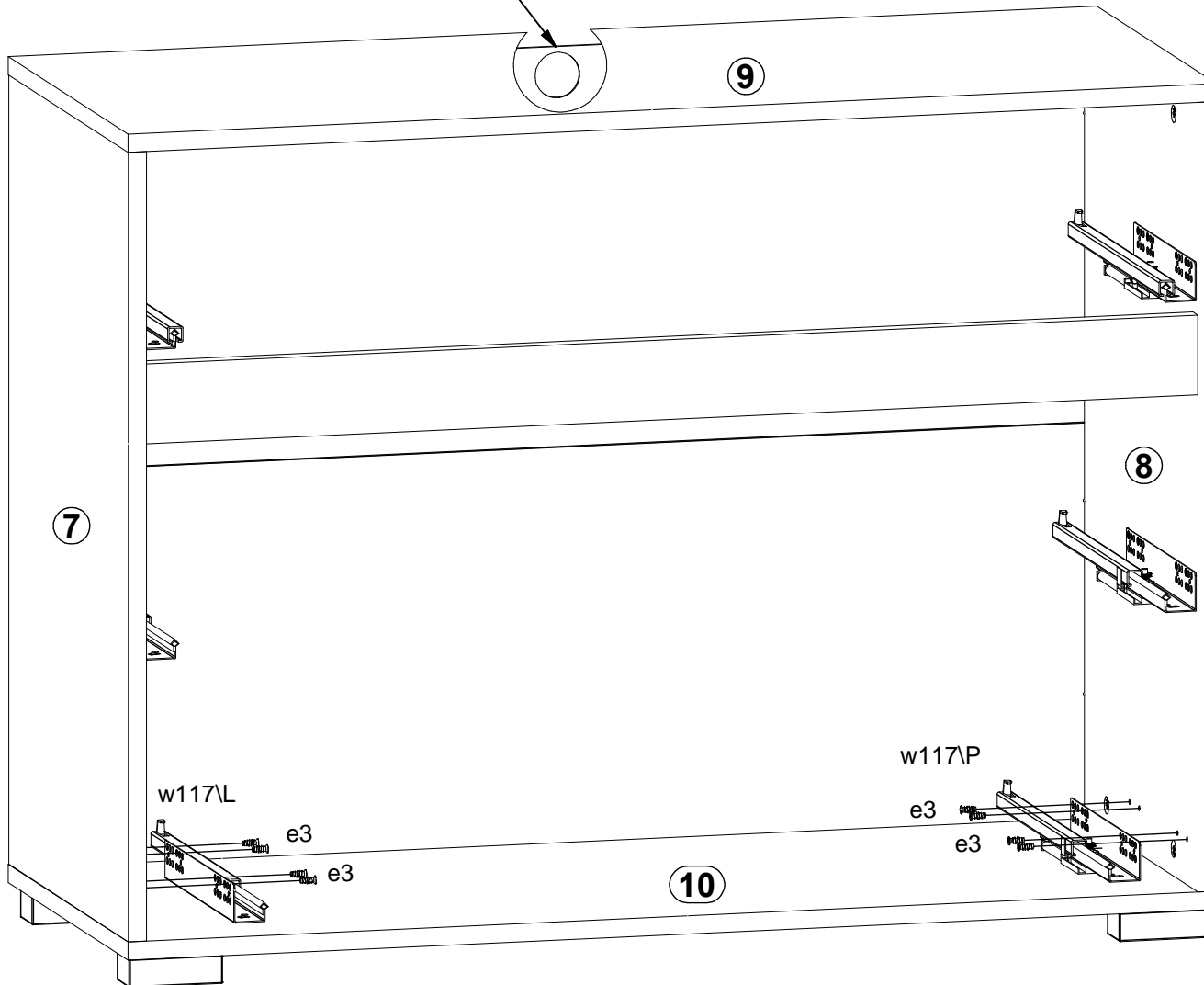

B

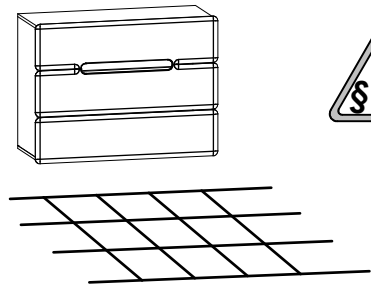

7

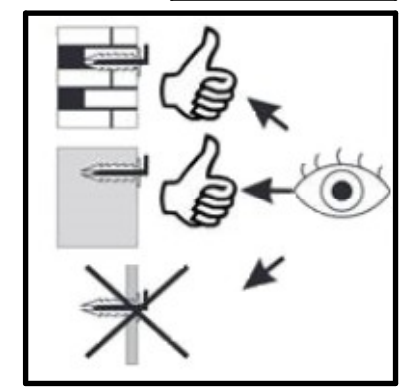
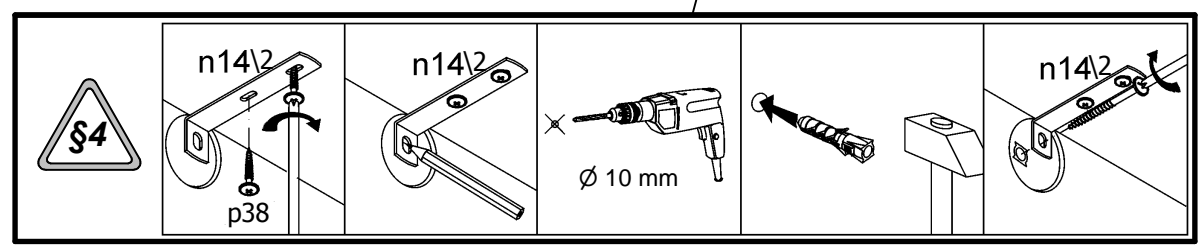
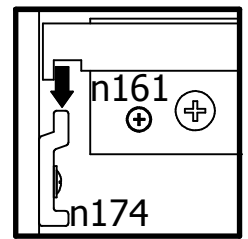
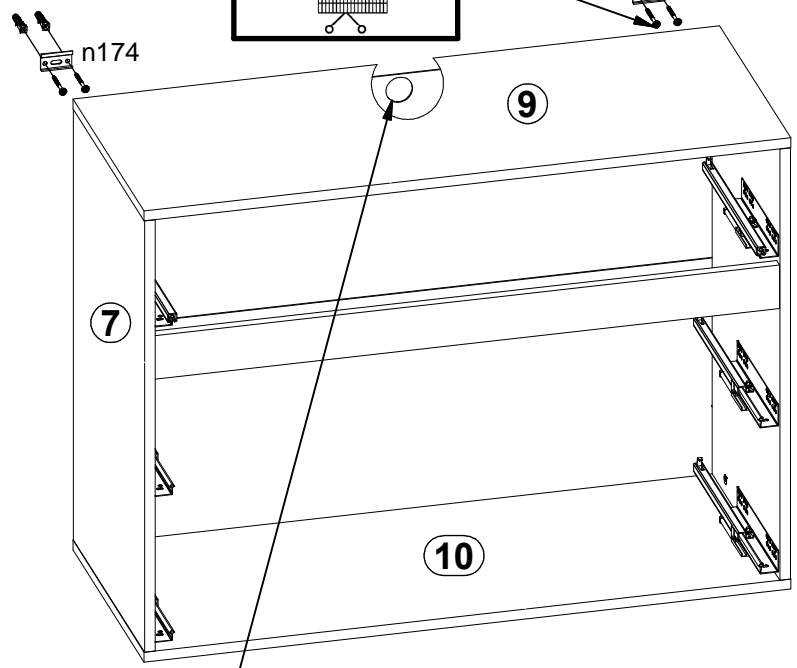
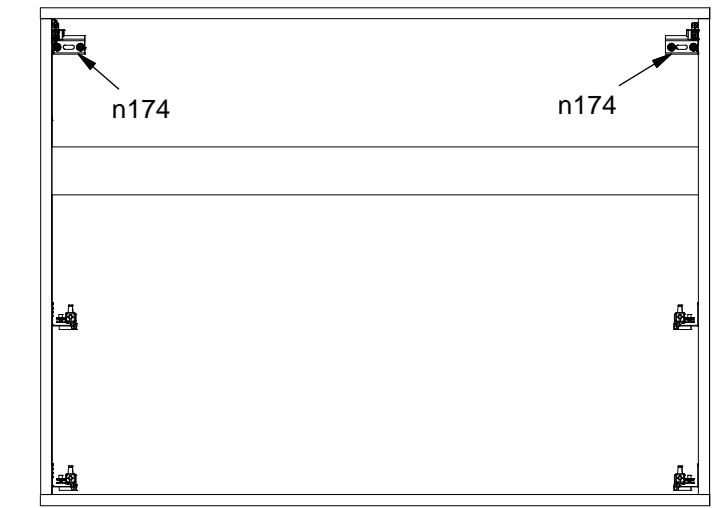
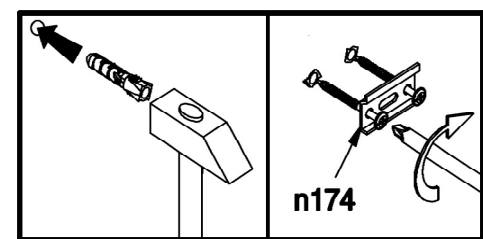
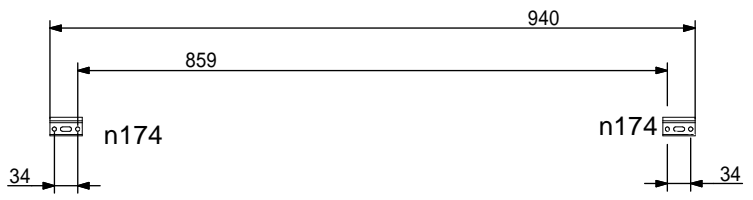
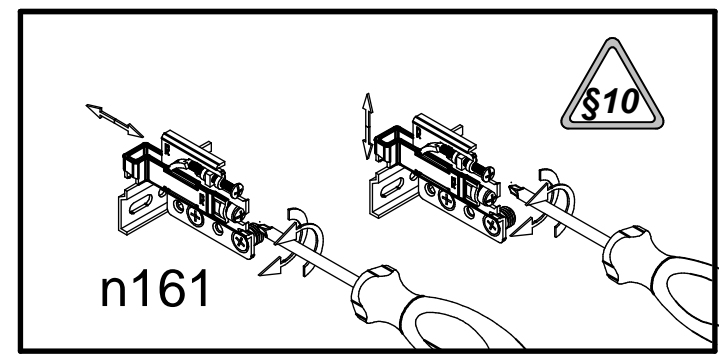
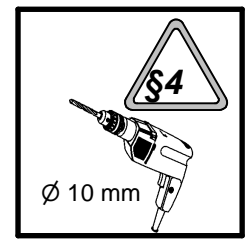

9

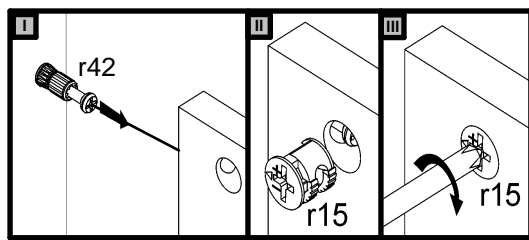
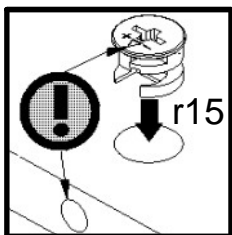
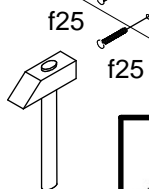
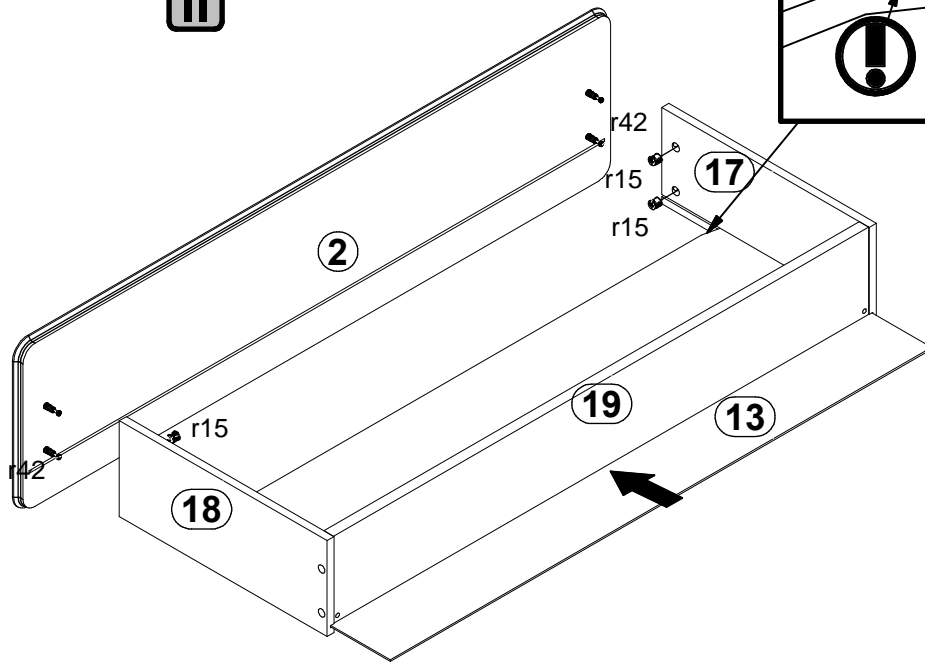
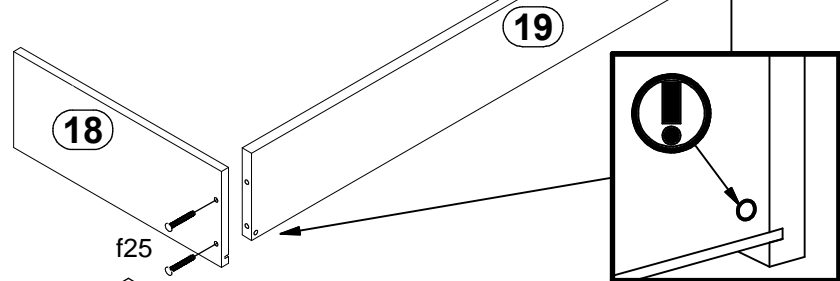
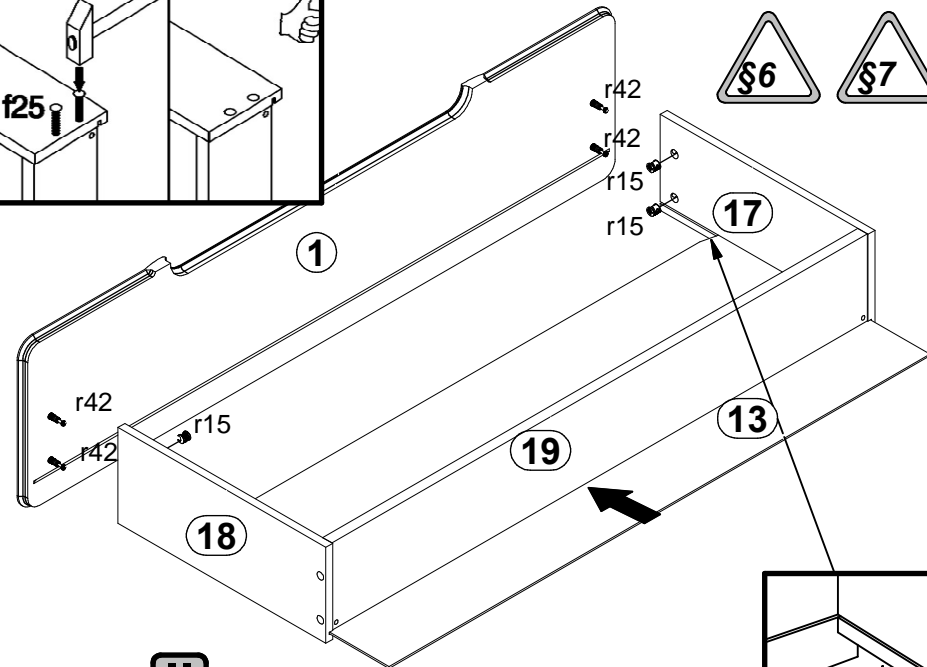
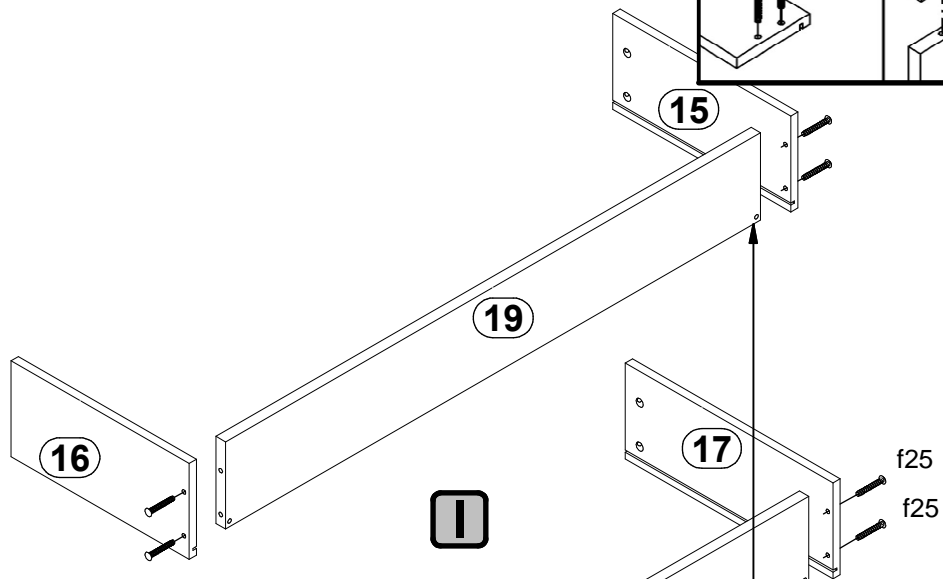
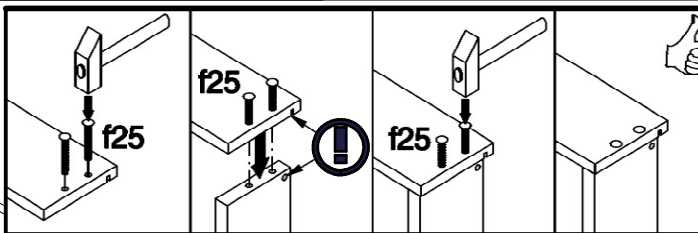

# 10

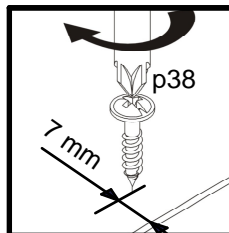
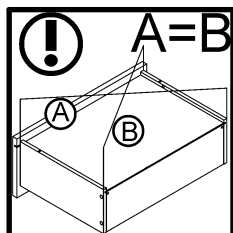
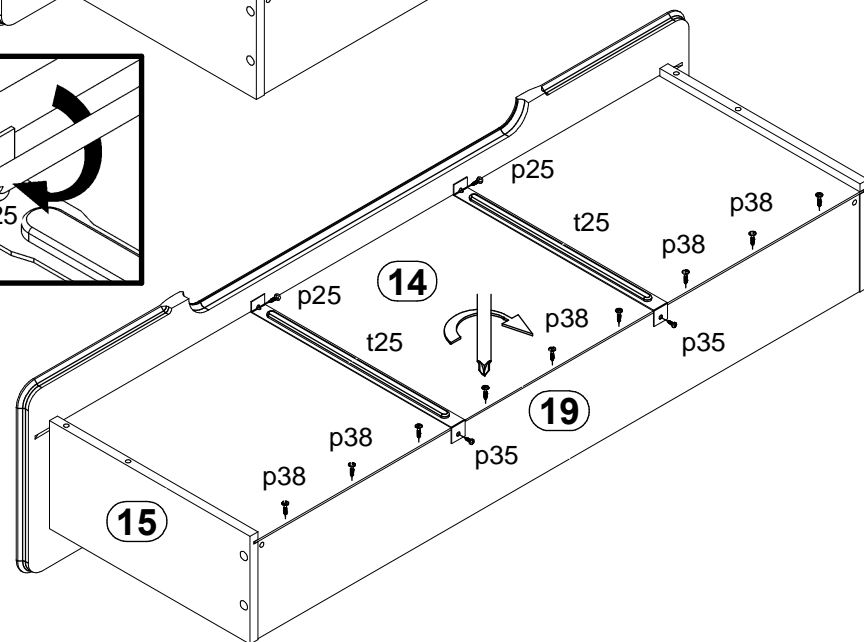
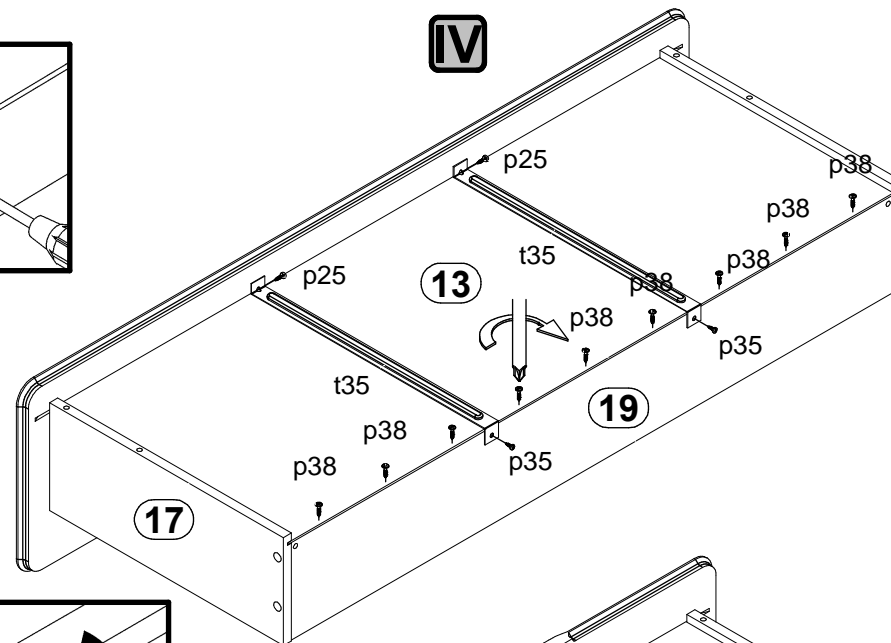
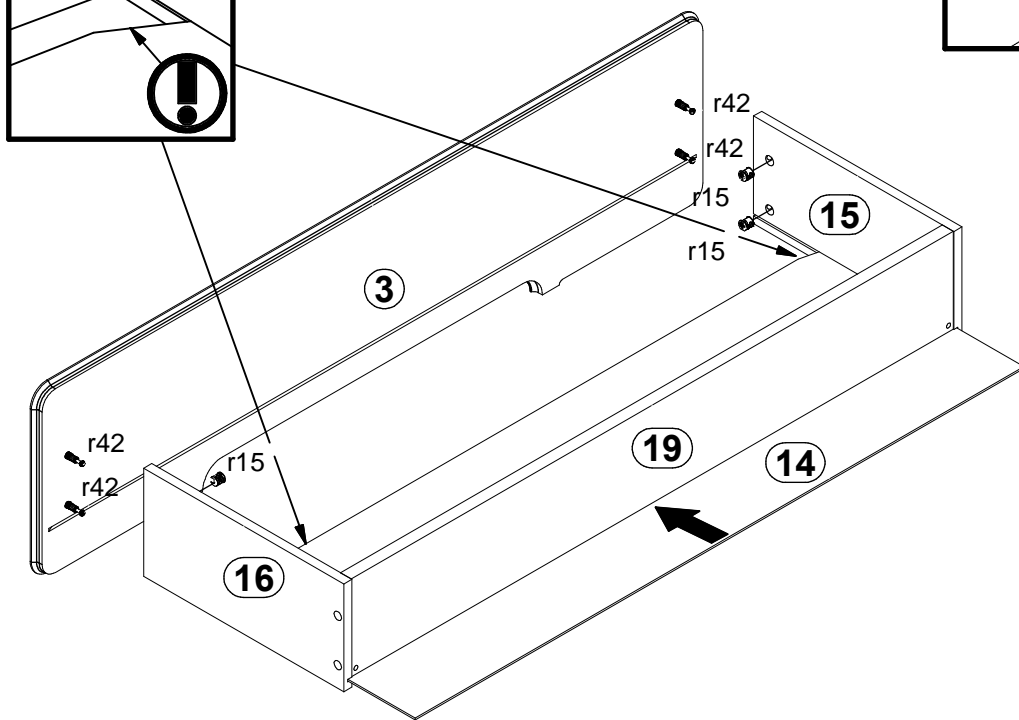
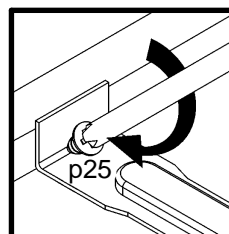
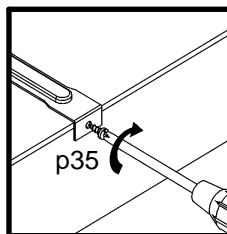
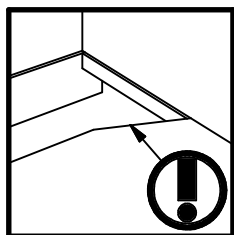



# 11

