

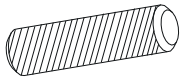

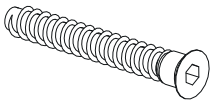

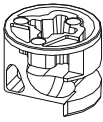



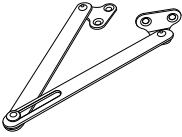
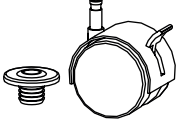
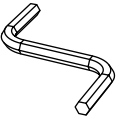
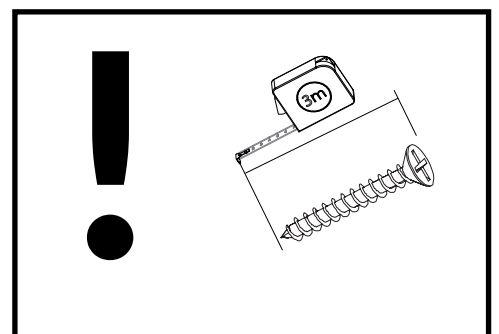

# DROP 12

<b>K1</b> x 8 8x32 	<b>KT1</b> x 12 6,3x50 	<b>B2</b> x 8 h-12 
<b>ZJ1</b> x 8 L-43 	<b>WT8</b> x 10 3x16 	<b>RN</b> x 1 
<b>KOH</b> x 4 	x 1 	



# DROP 12

	CODE				
1	Drop12_01	728	400	1	1/2K
2	Drop12_02	315	397	2	1/2K
3	Drop12_03	681	295	1	1/2K
4	Drop12_04	681	310	1	1/2K
5	Drop12_05	745	447	1	2/2K
6					
7					
8					
9					
10					

	CODE				
11					
12					
13					
14					
15					
16					
17					
18					
19					
20					

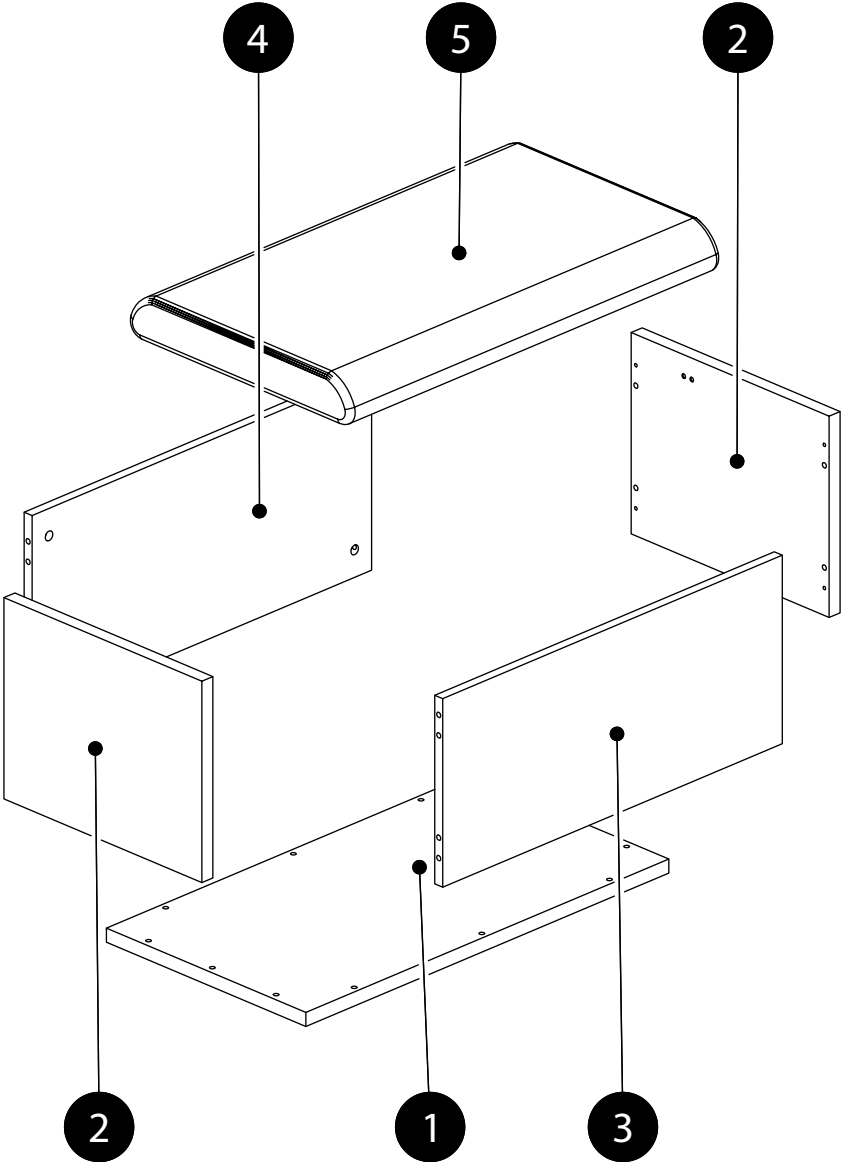

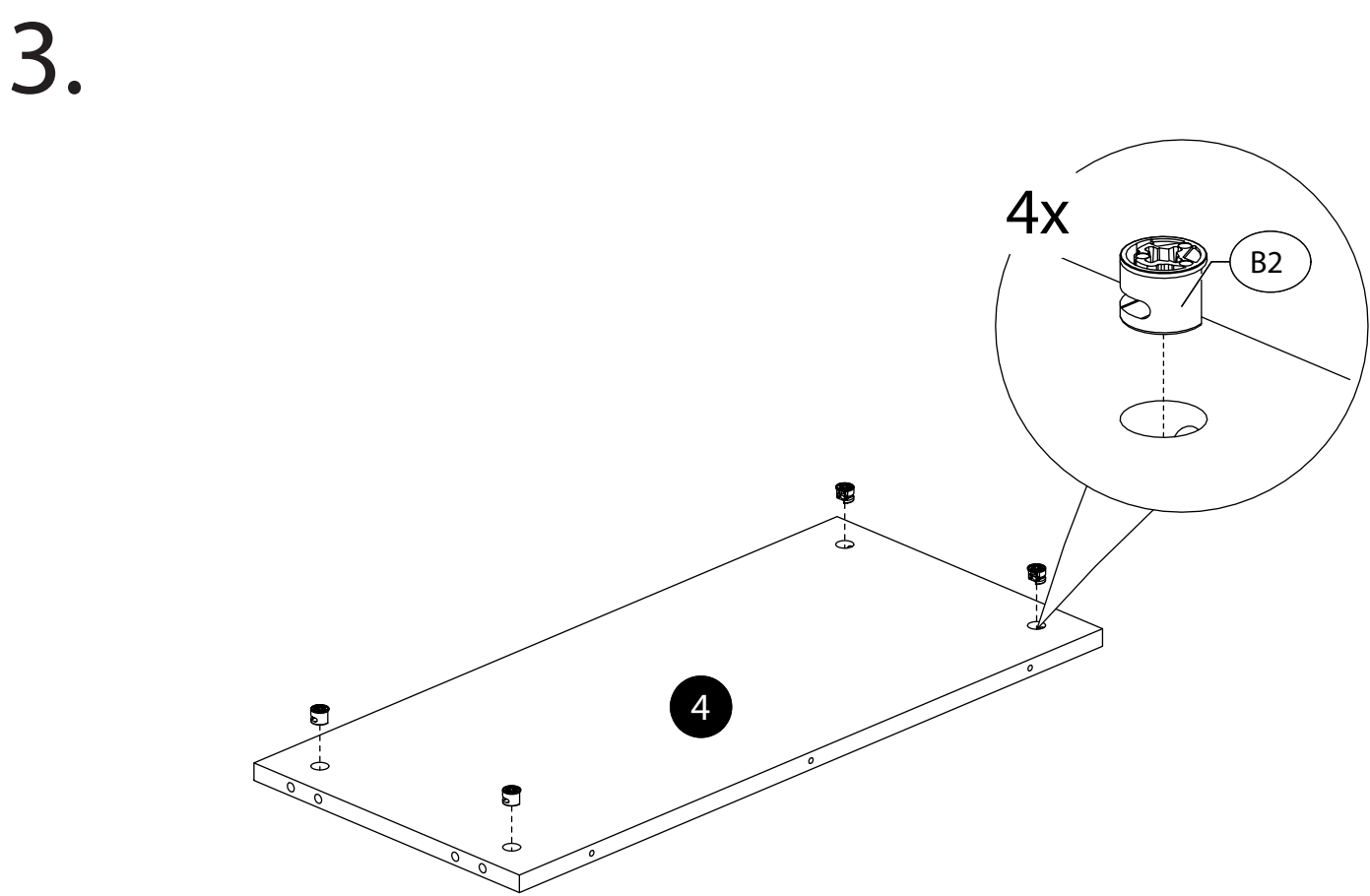
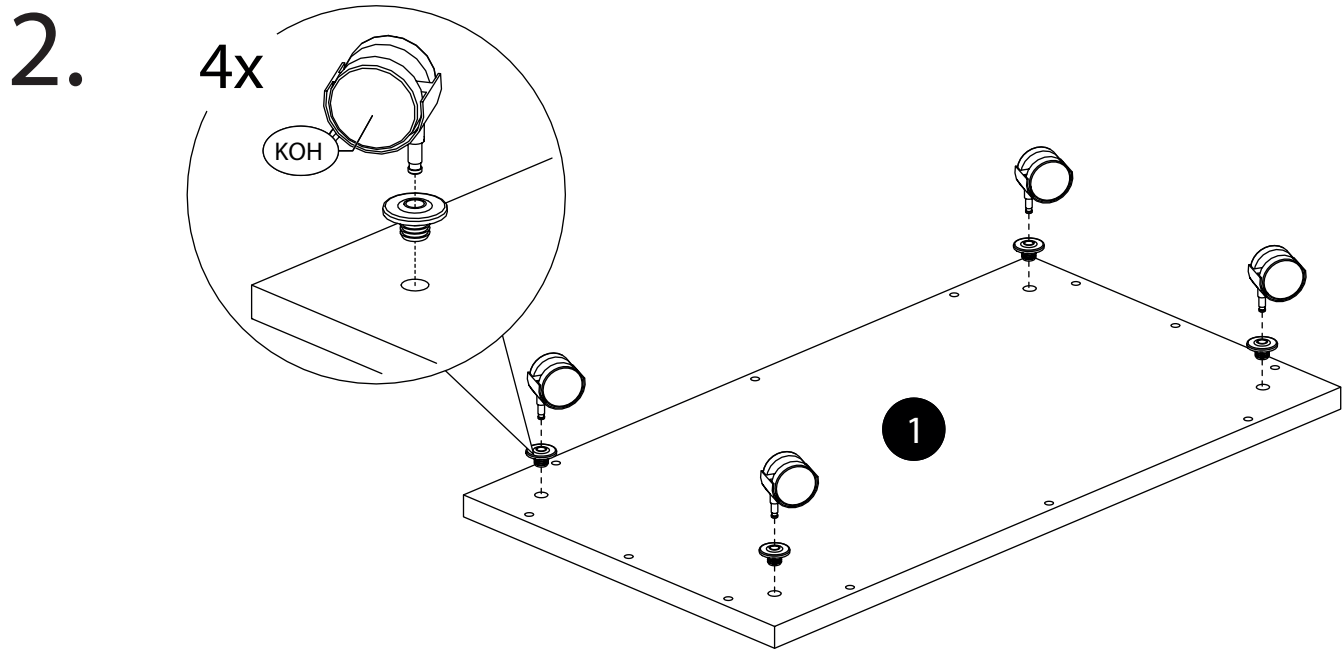
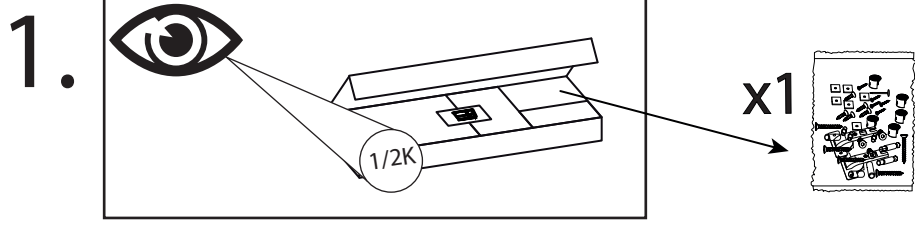

4.

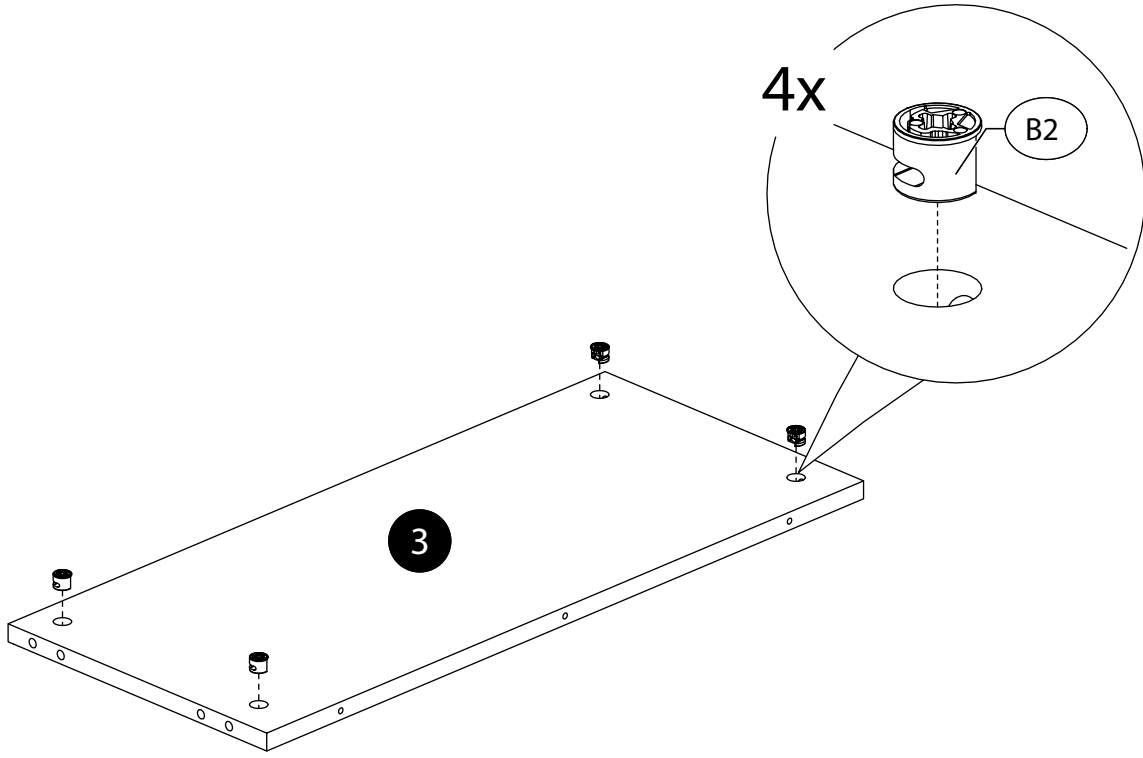

5.

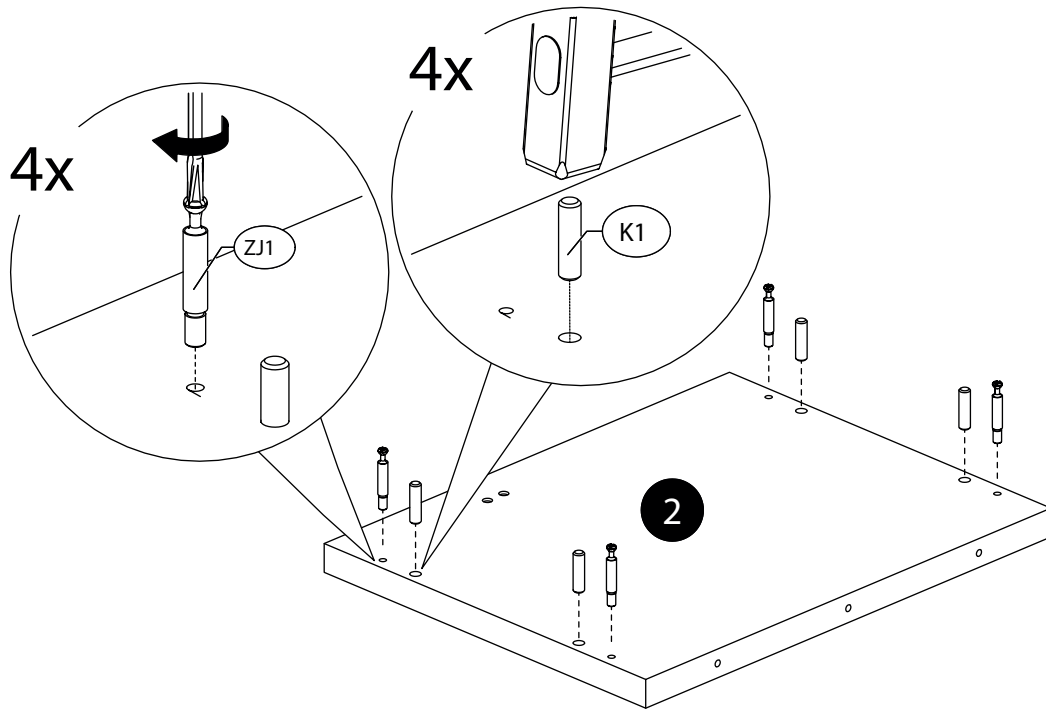

6.

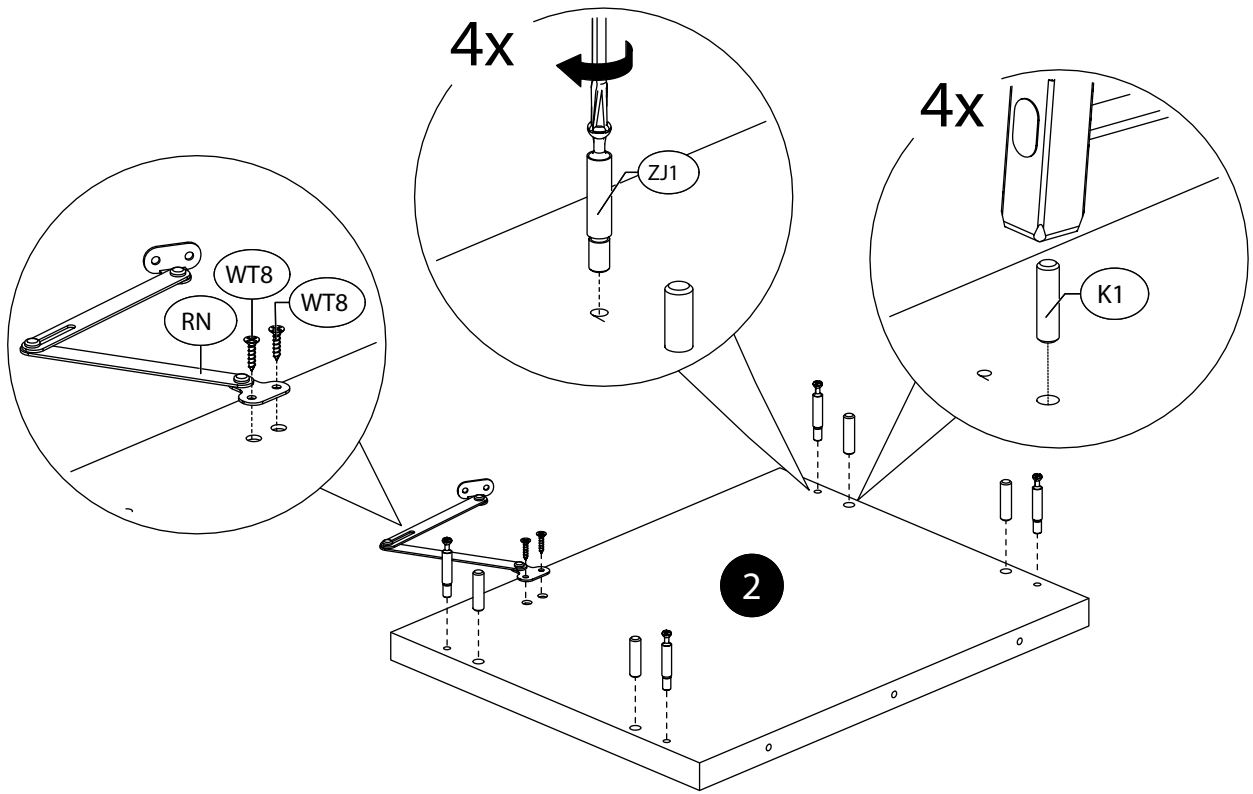

7.

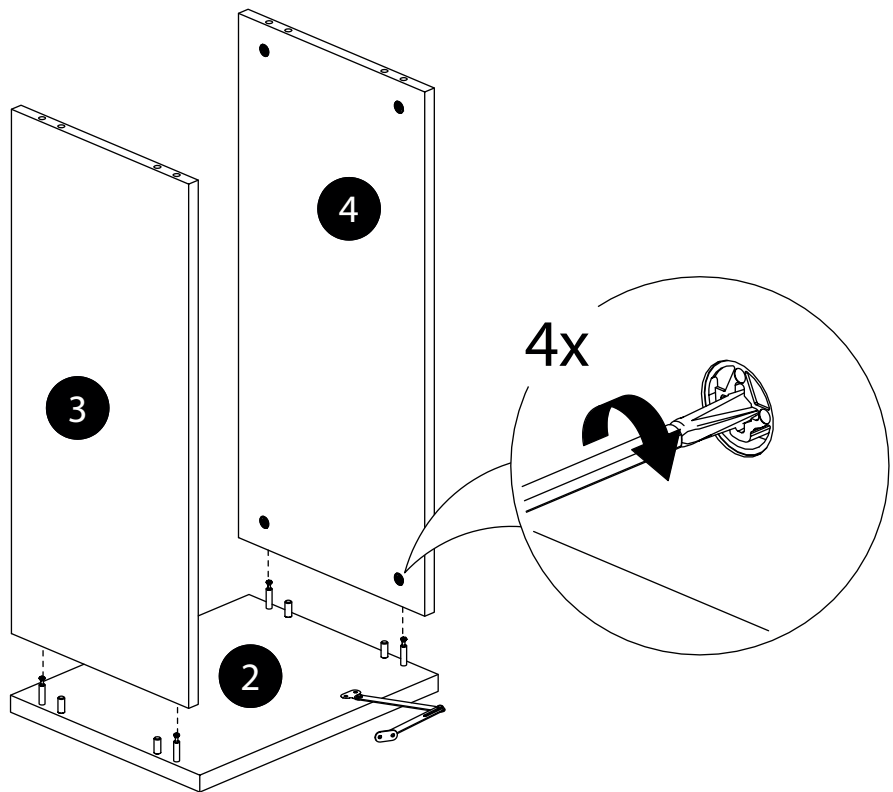

8.

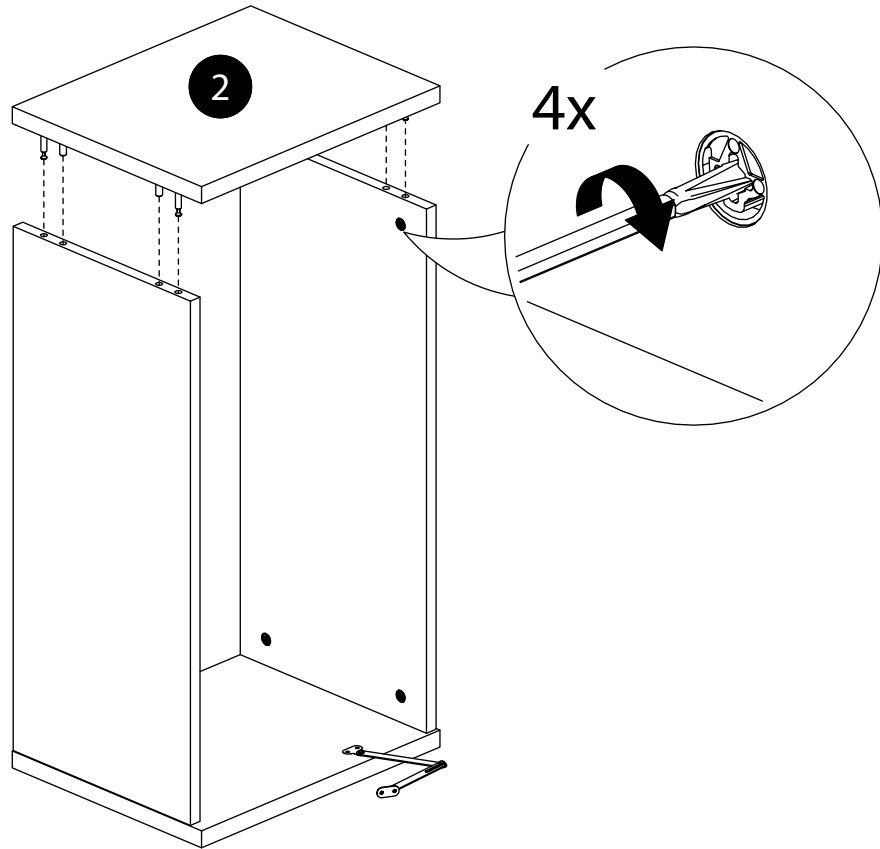

9.

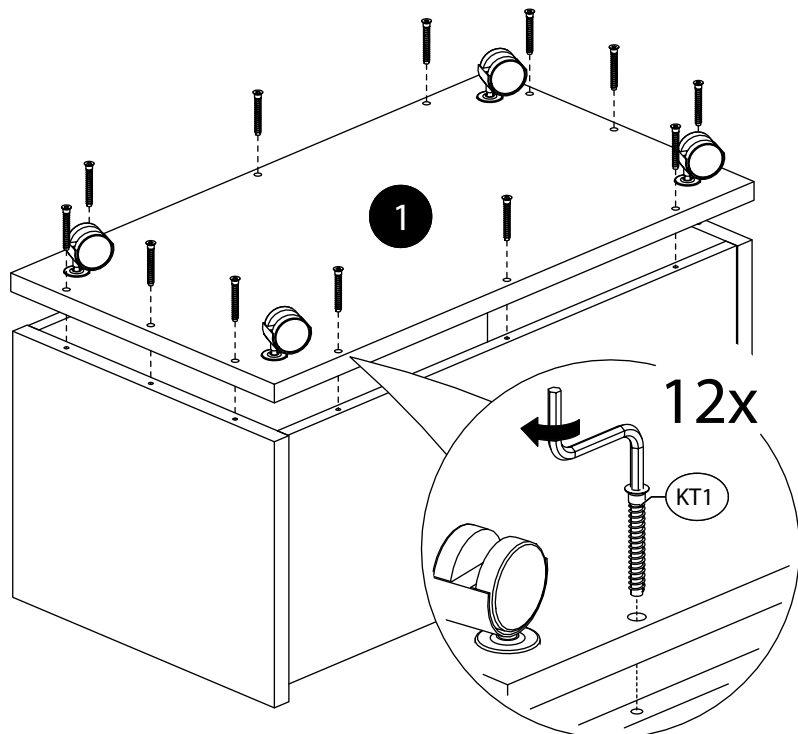
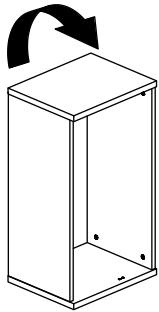



10.

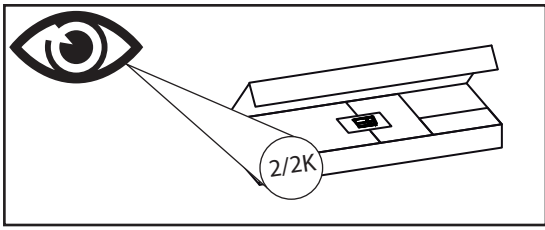

11.

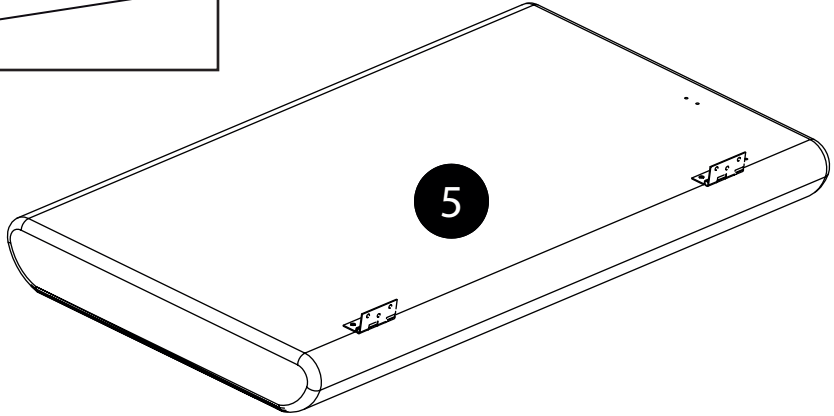

12.

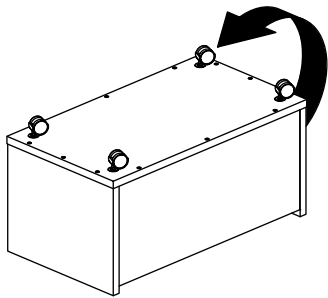

2x

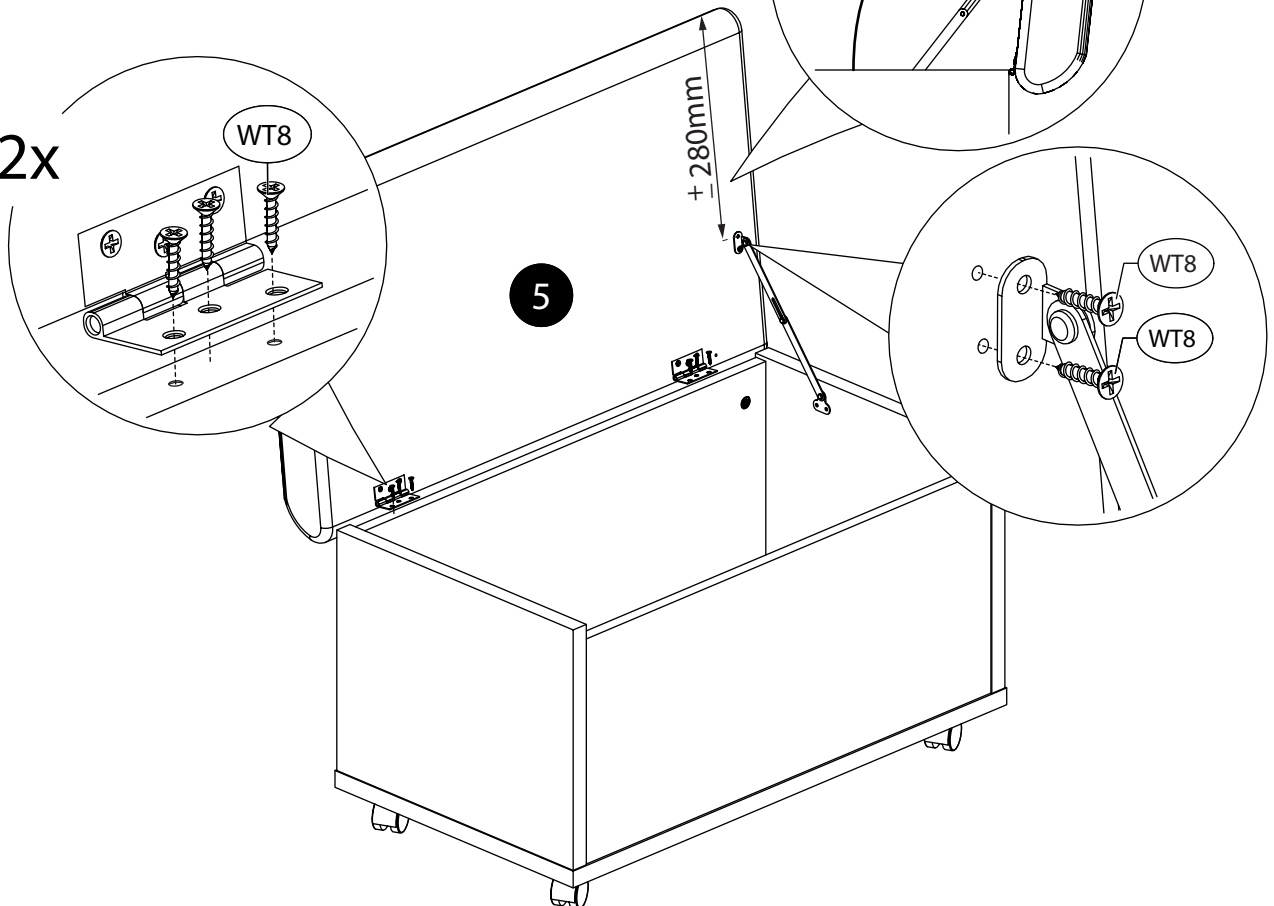

13.

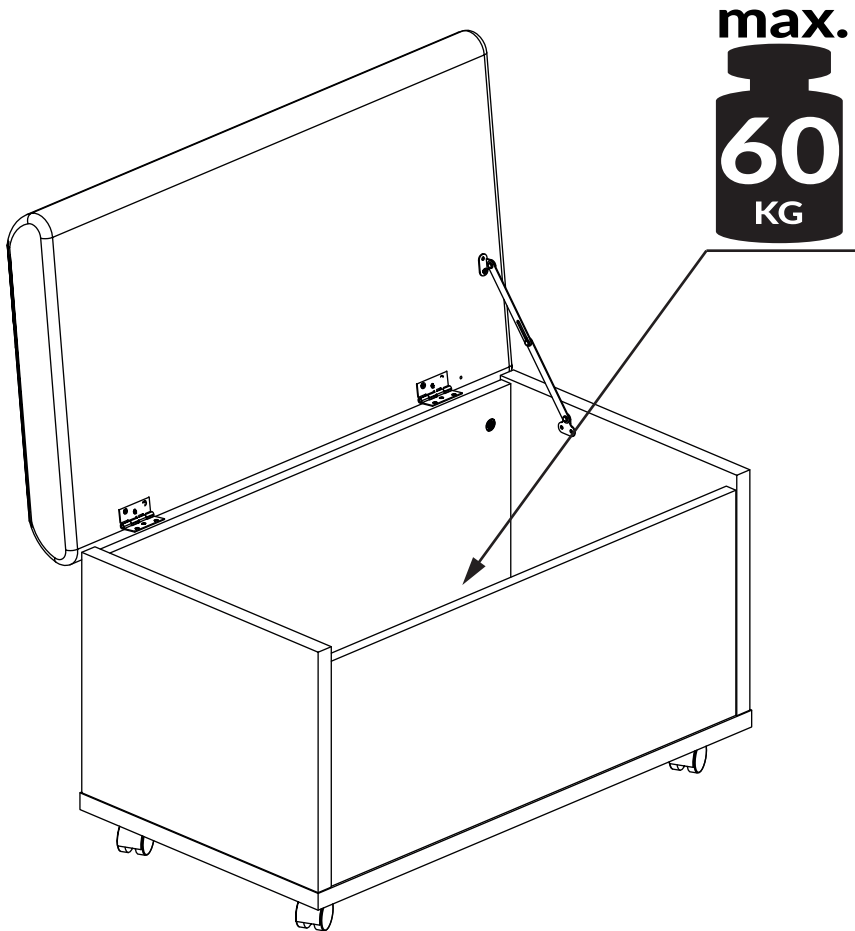

14.

