

Vitrine art. 0316/3-A2

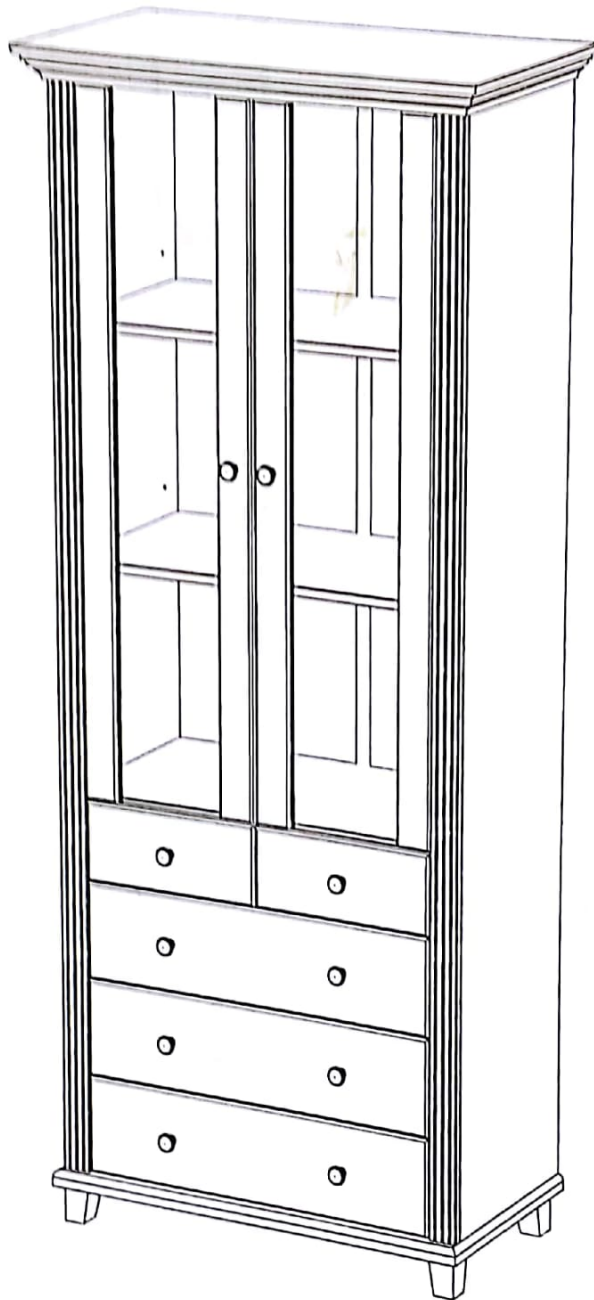

Assembled size / Maße aufgebaut :

Height / Höhe : 1804 mm.

Width / Breite : 800 mm.

Depth / Tiefe : 388 mm.

This unit can be assembled by two persons.

Aufbau mit zwei Personen.

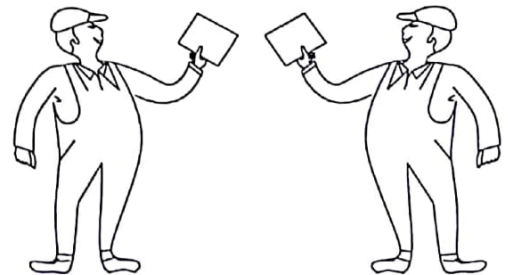





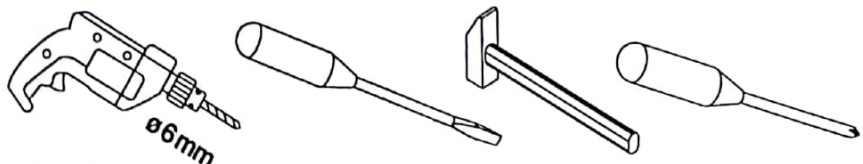

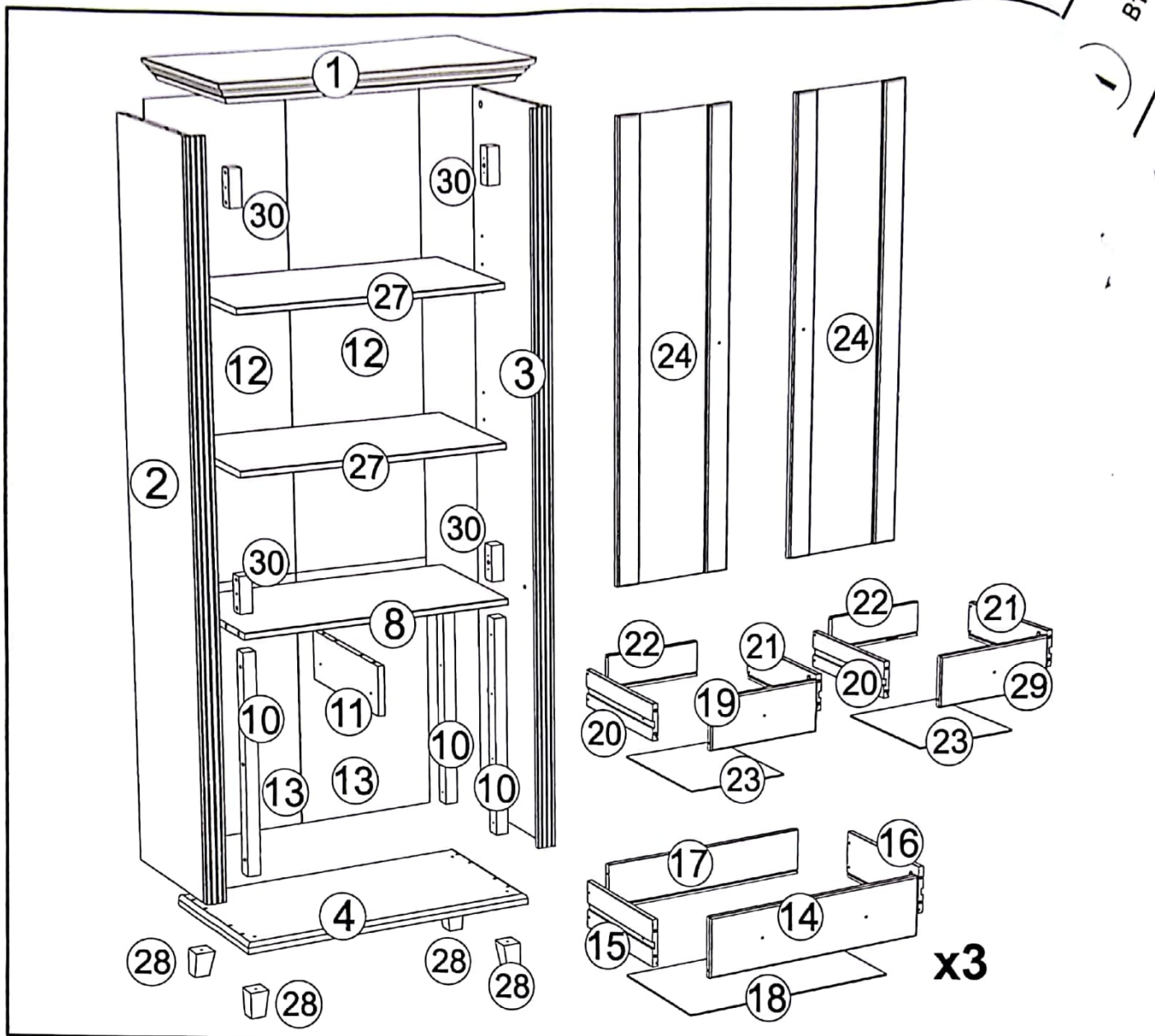



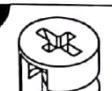

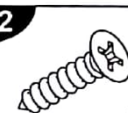
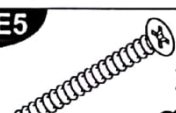
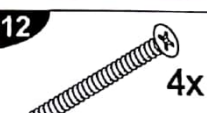
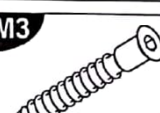
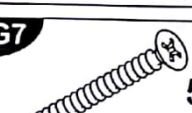

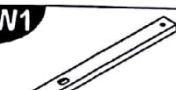

The necessary tools
(not included)

Die dazu benötigten Werkzeuge
(ausschliesslich)



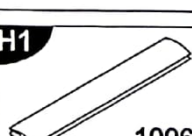
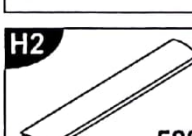

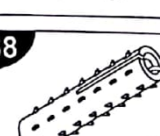
A1  1x	B1  38x Ø8x35	C1  26x 34 mm	D1  26x 12 mm	D3  20x Ø17
F2  37x Ø3.5x15	E5  20x Ø3x30	G12  4x Ø5x60	M3  4x Ø7x50	G7  5x Ø4x40
J1  10x M4x12	J2  10x M4x22	R7  10x	Z1  1x SW4	W1  10x 310 mm
N1  52x	X1  4x	V1  4x	P1  4x	Q1  8x
H1  1x 1096 mm	H2  1x 588 mm	L1  1x	B8  1x Ø6x30	

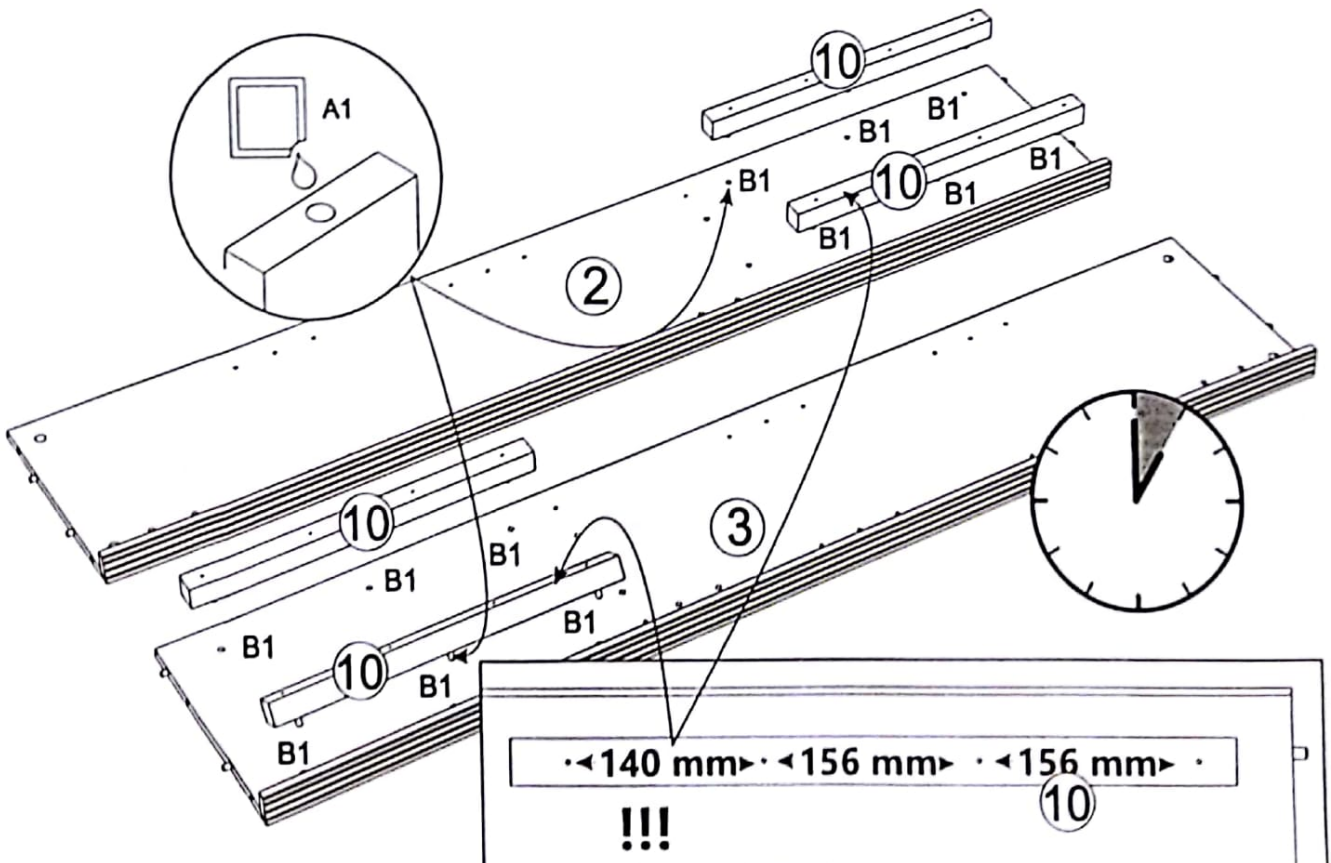
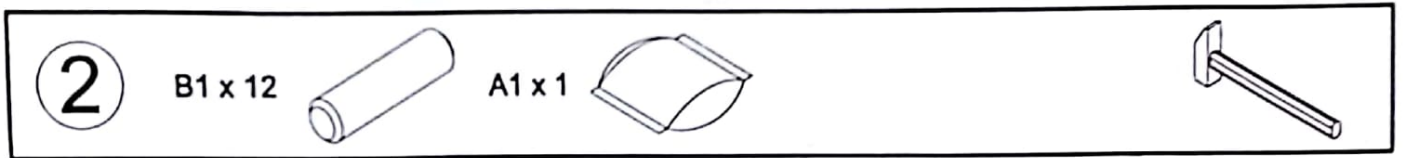
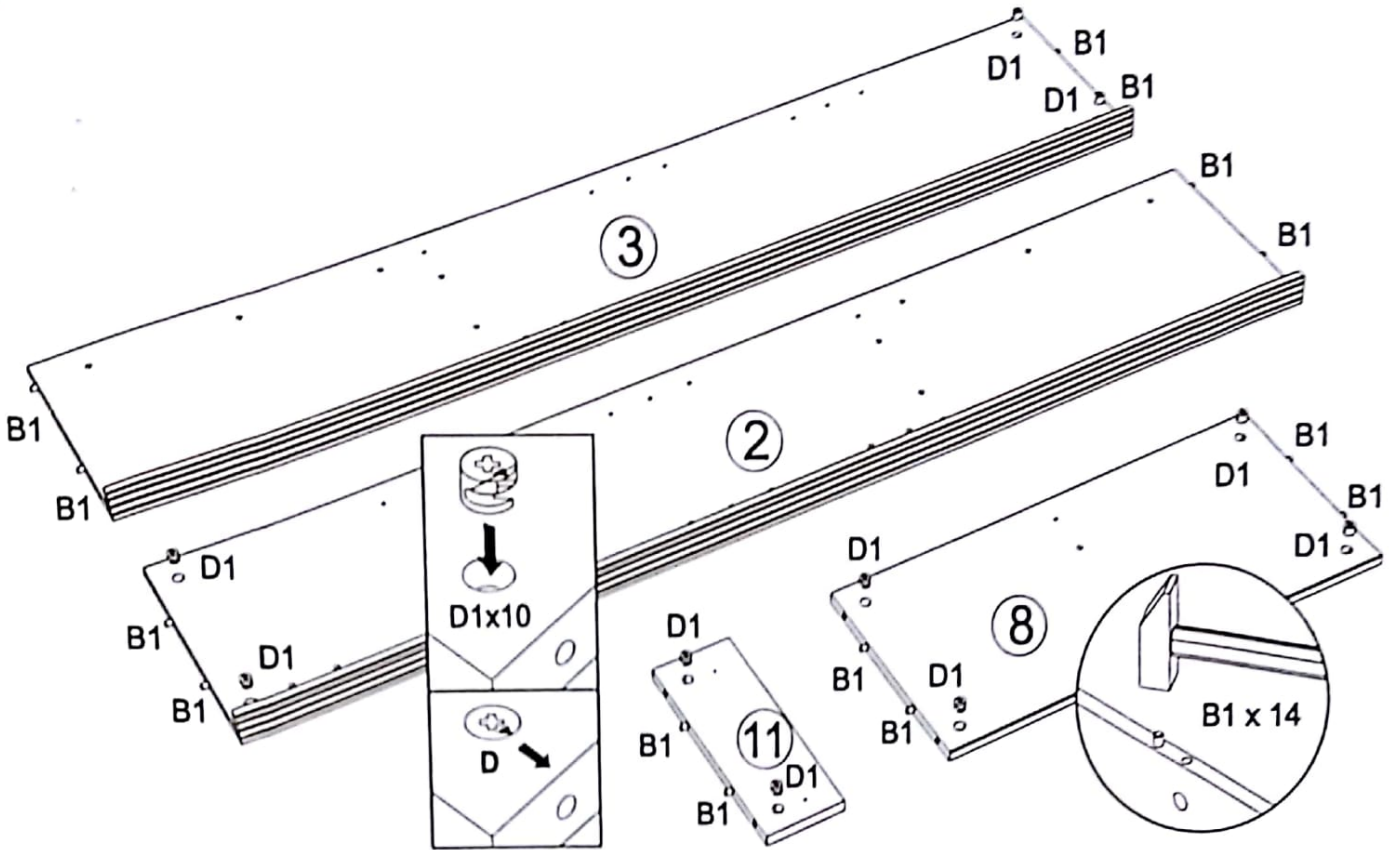

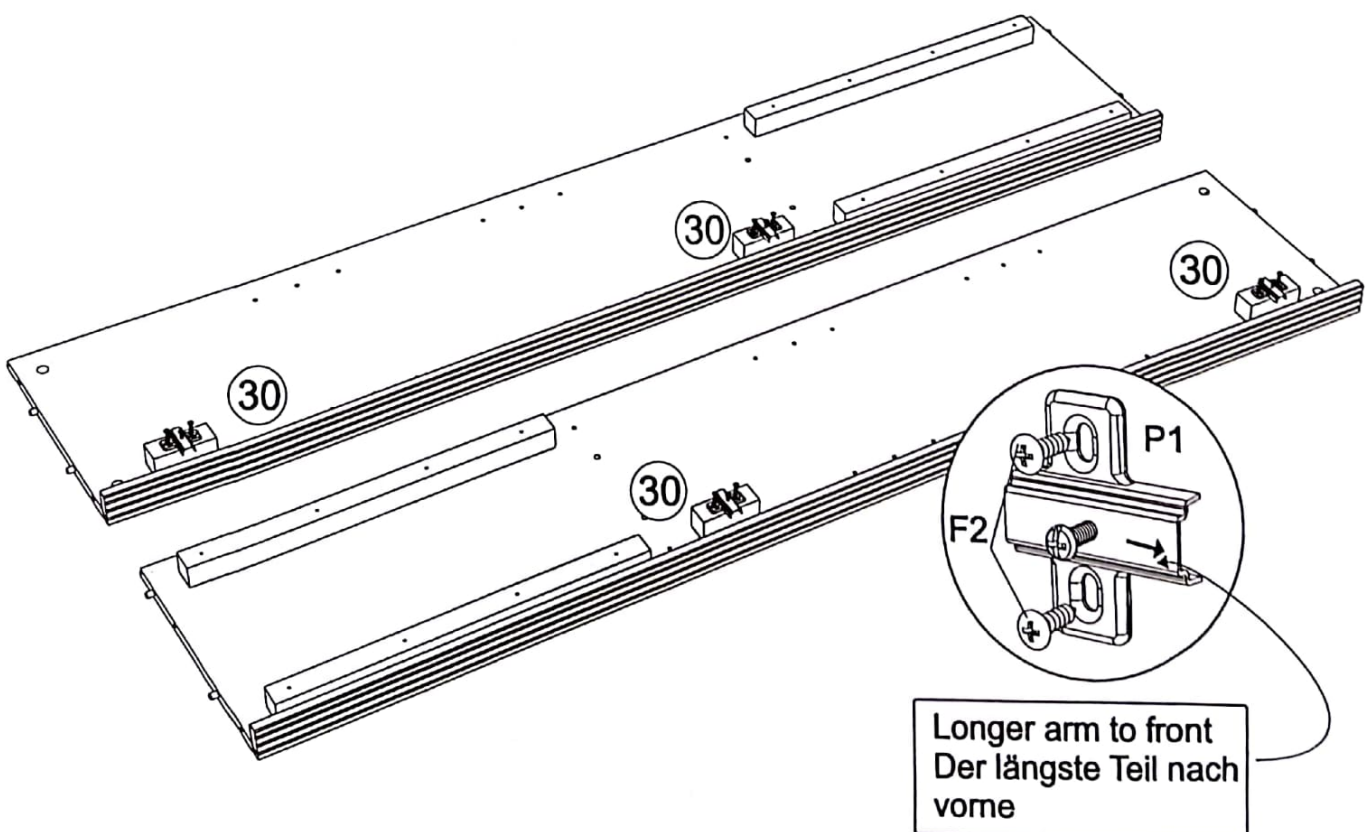
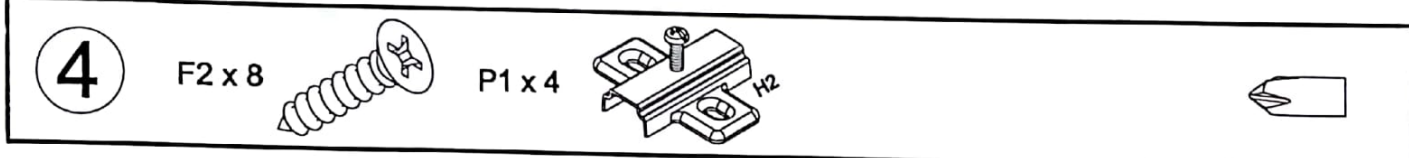
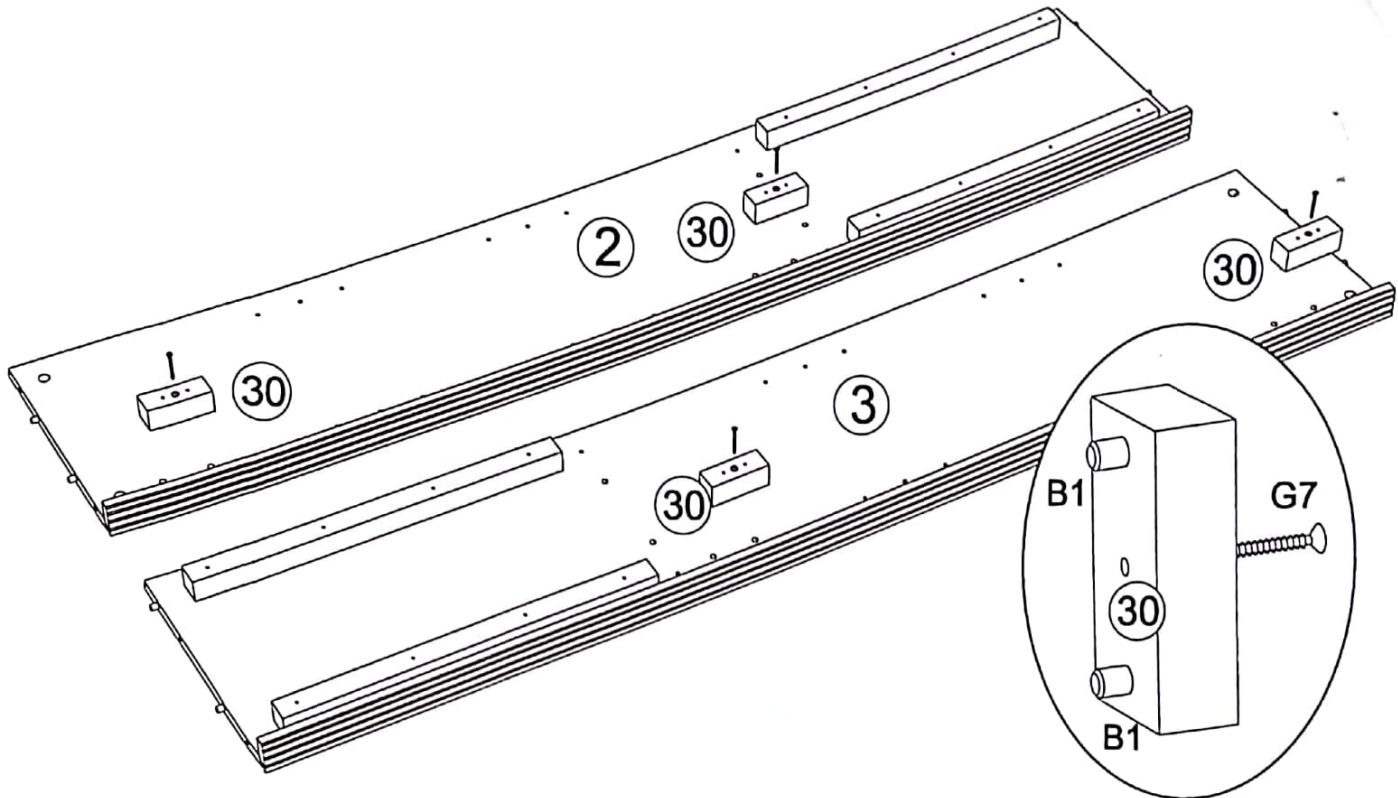
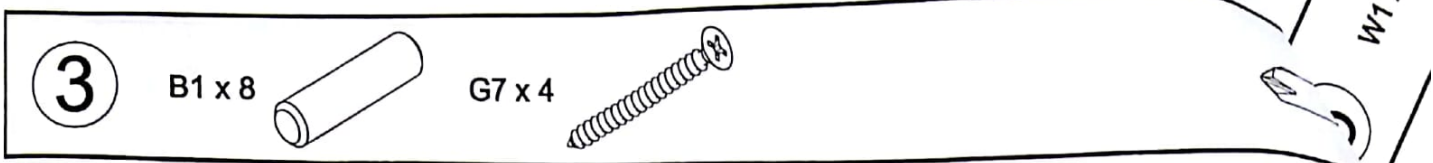

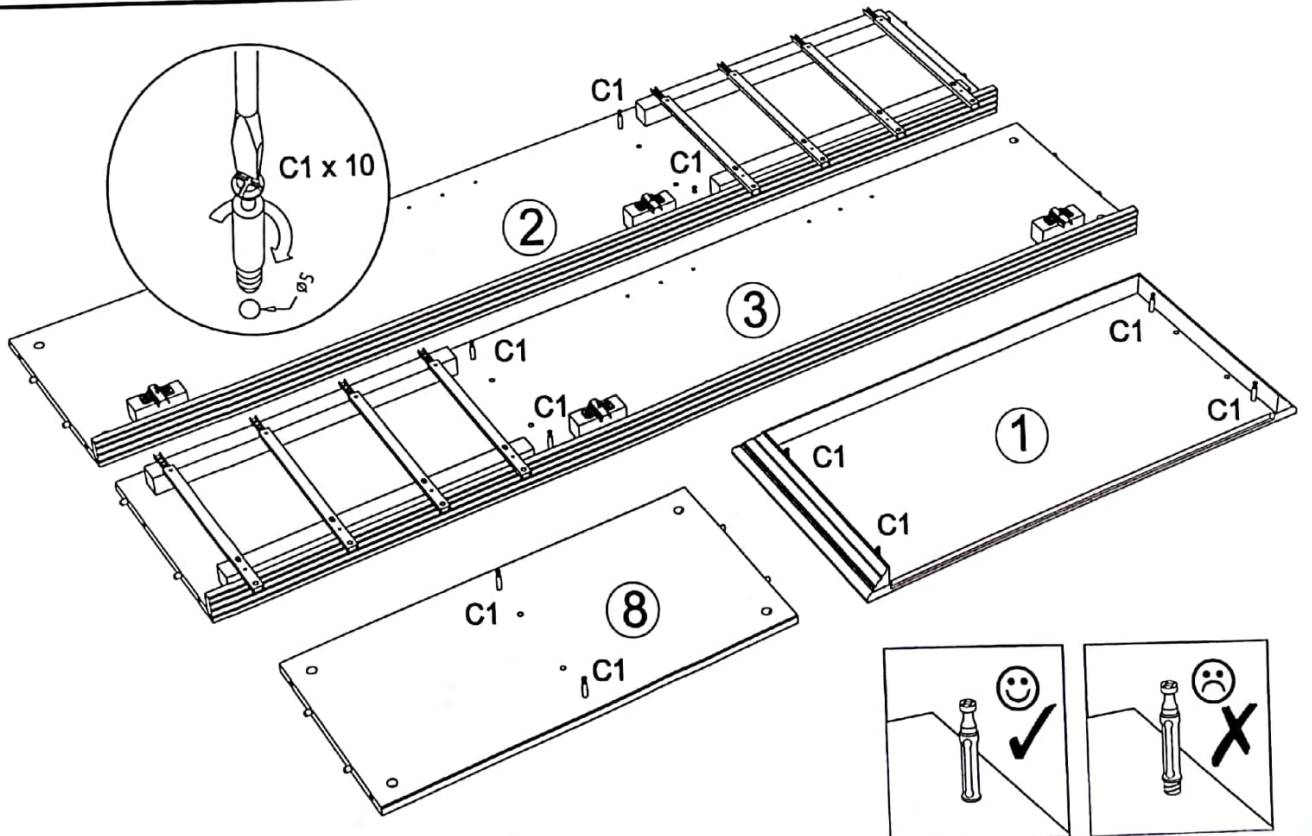
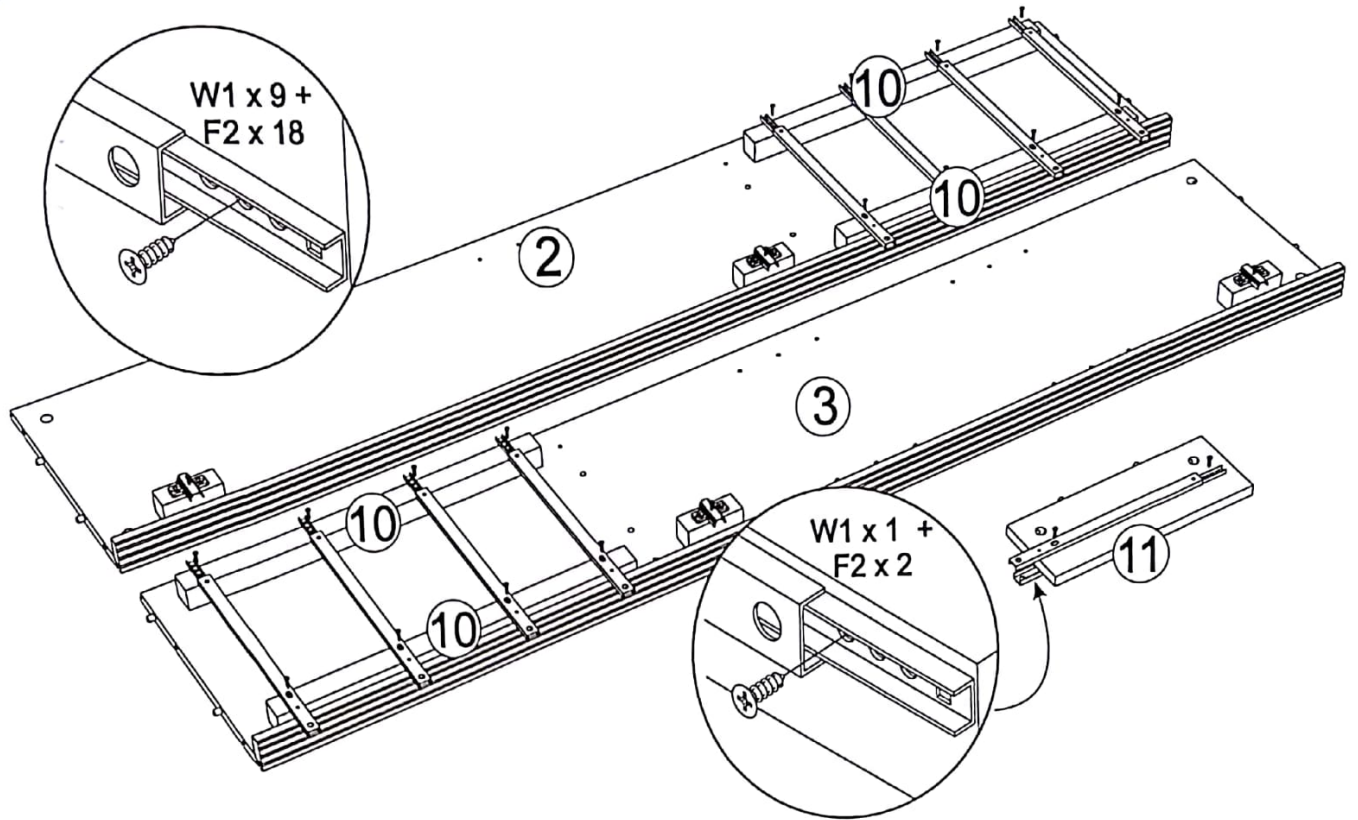
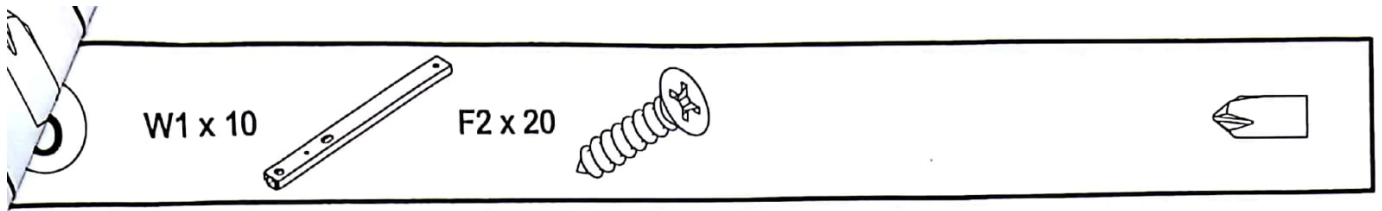

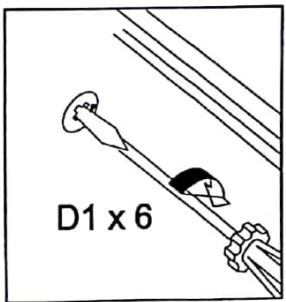
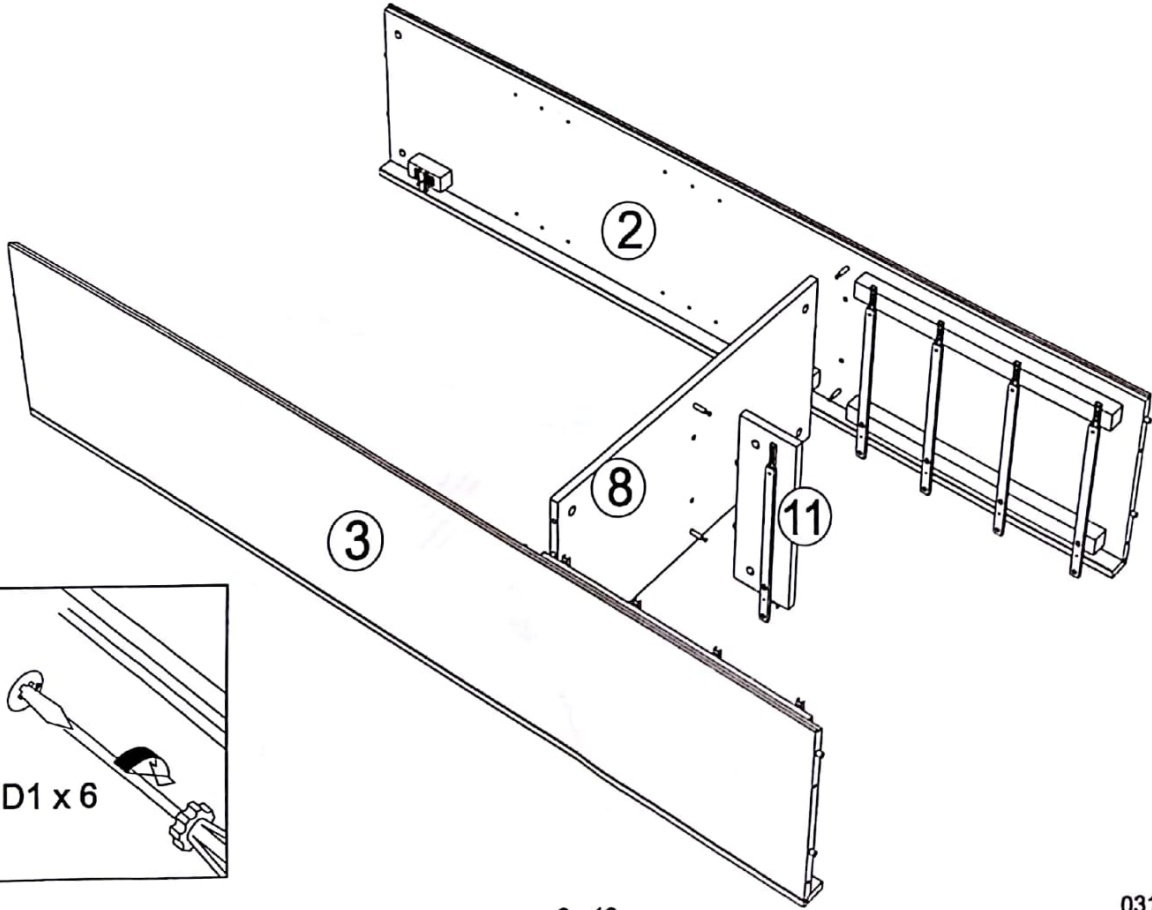
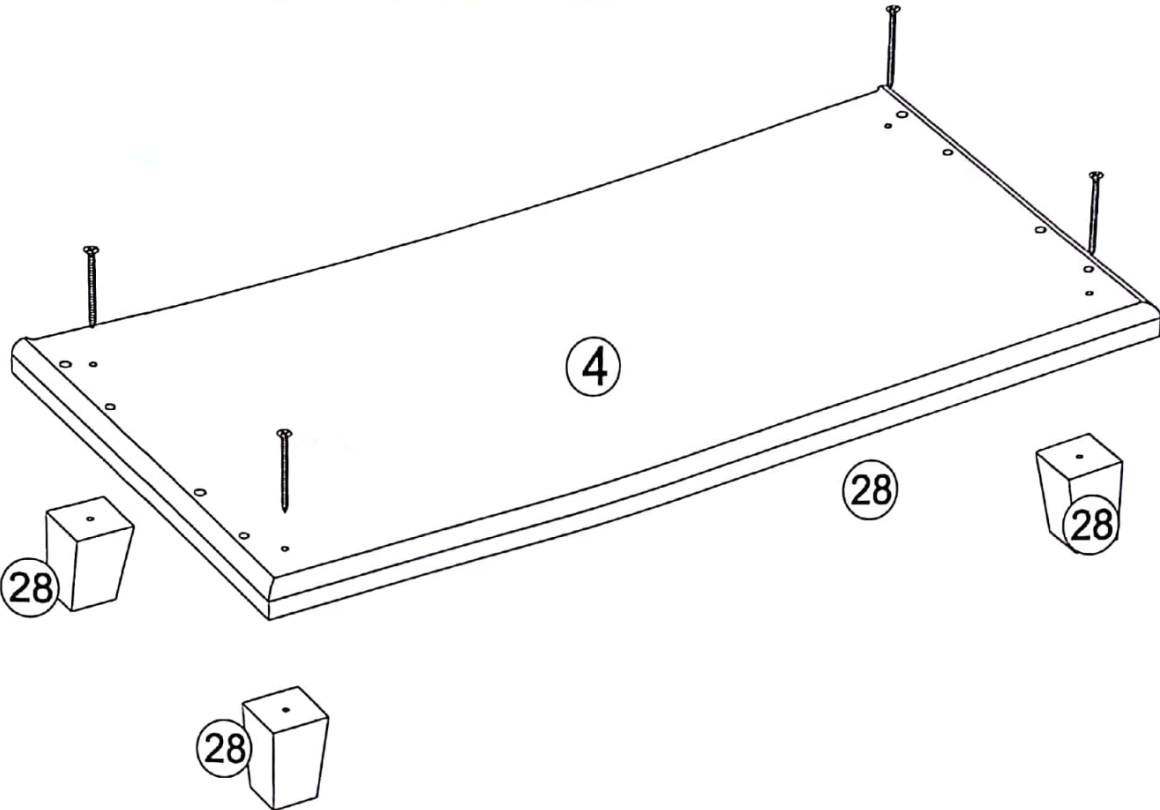

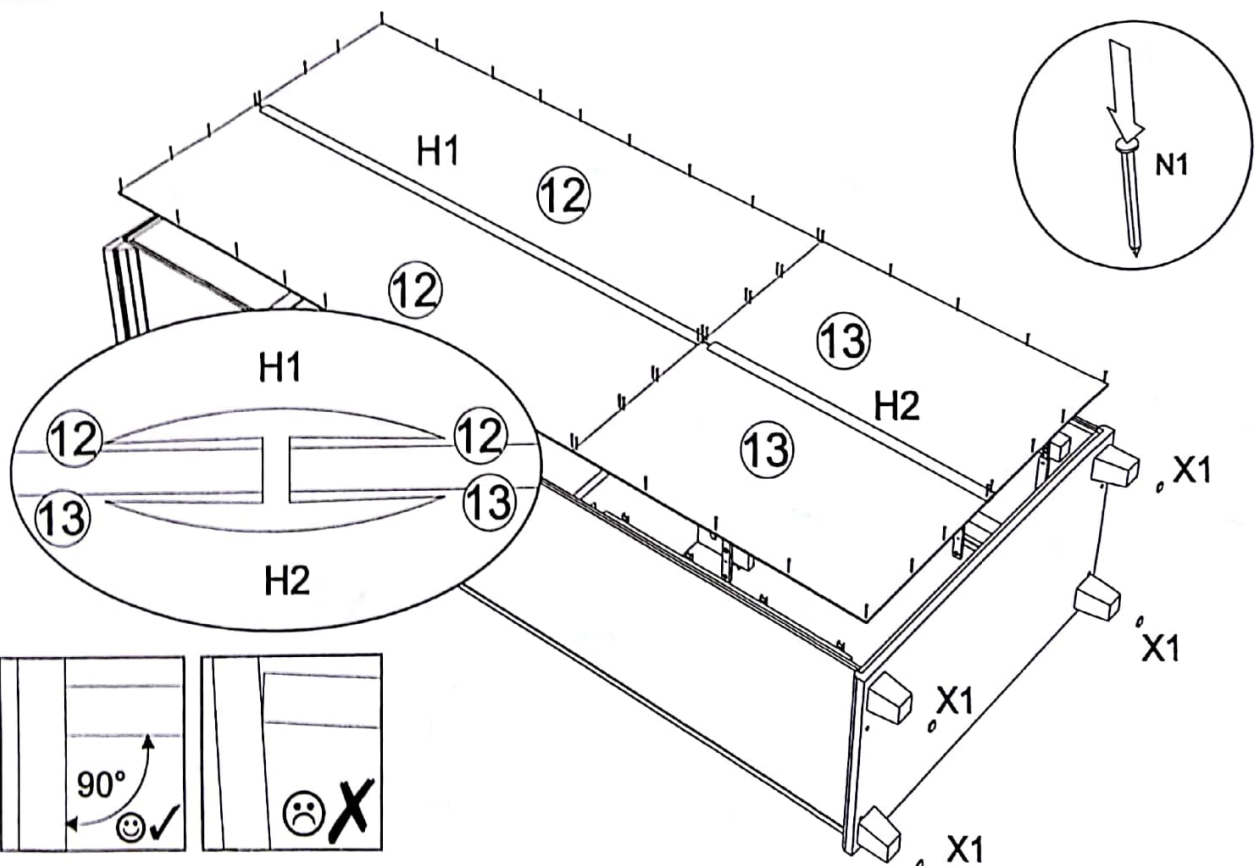
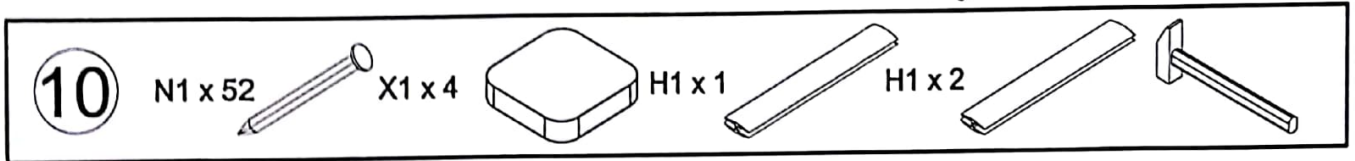
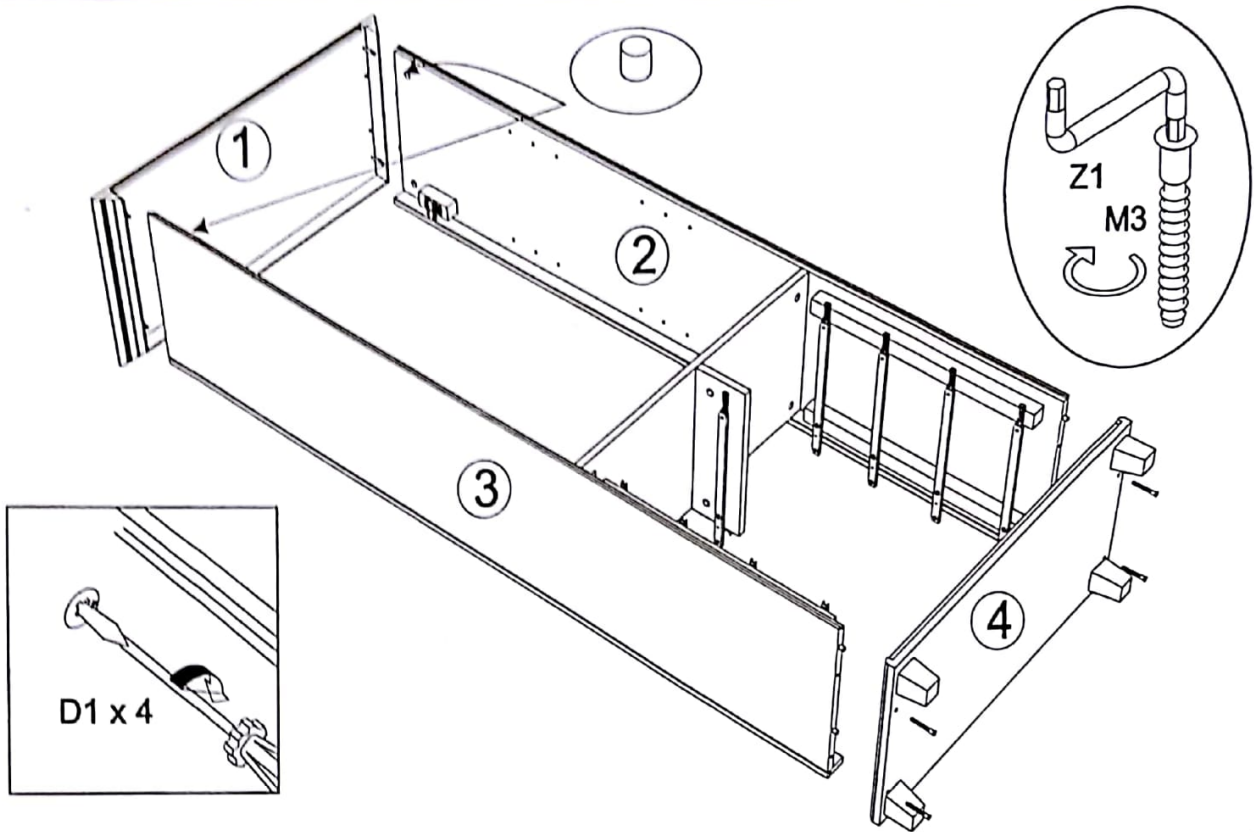
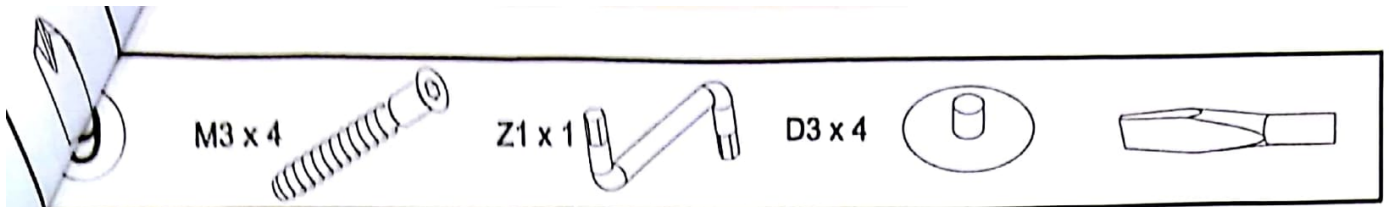

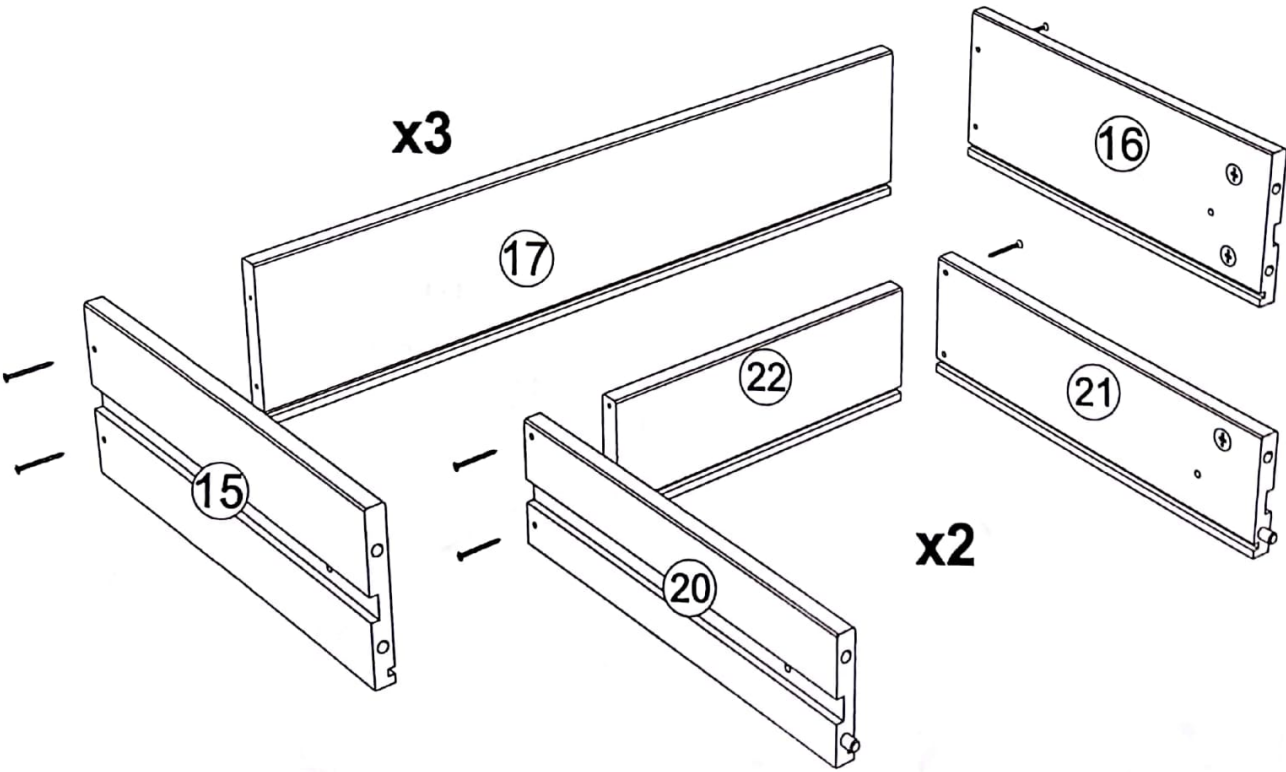
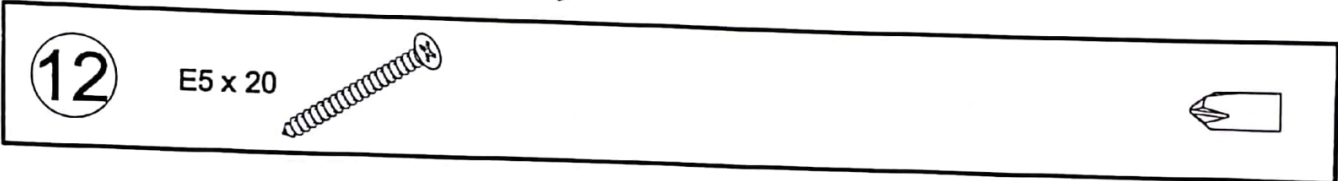
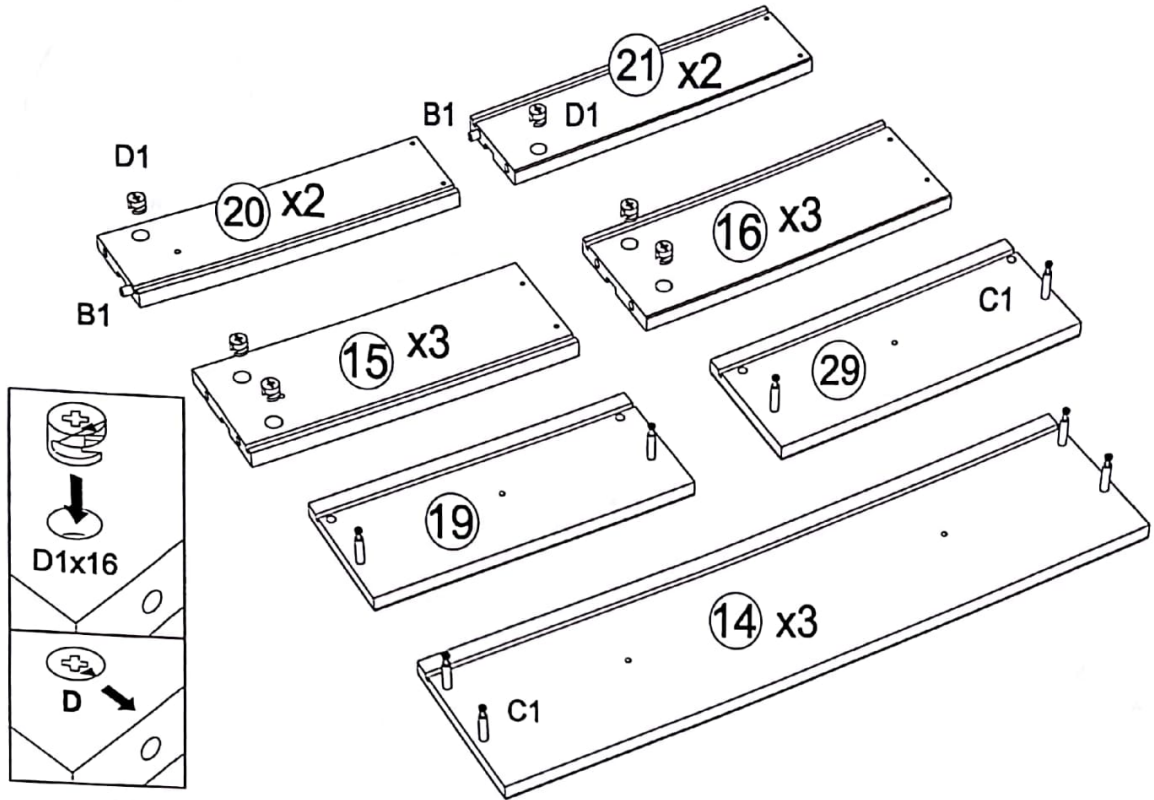
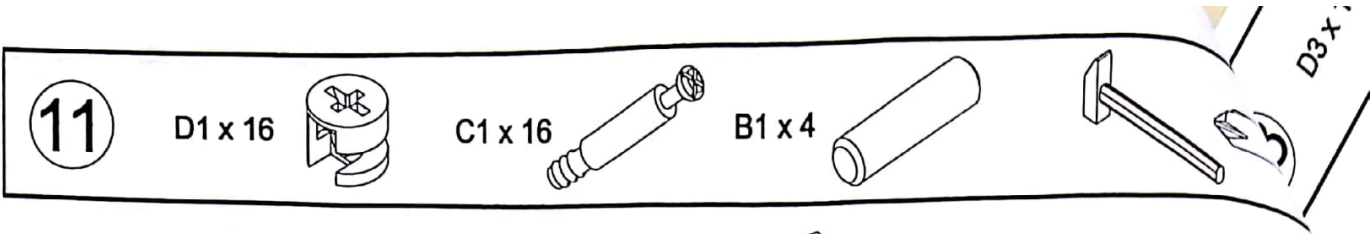

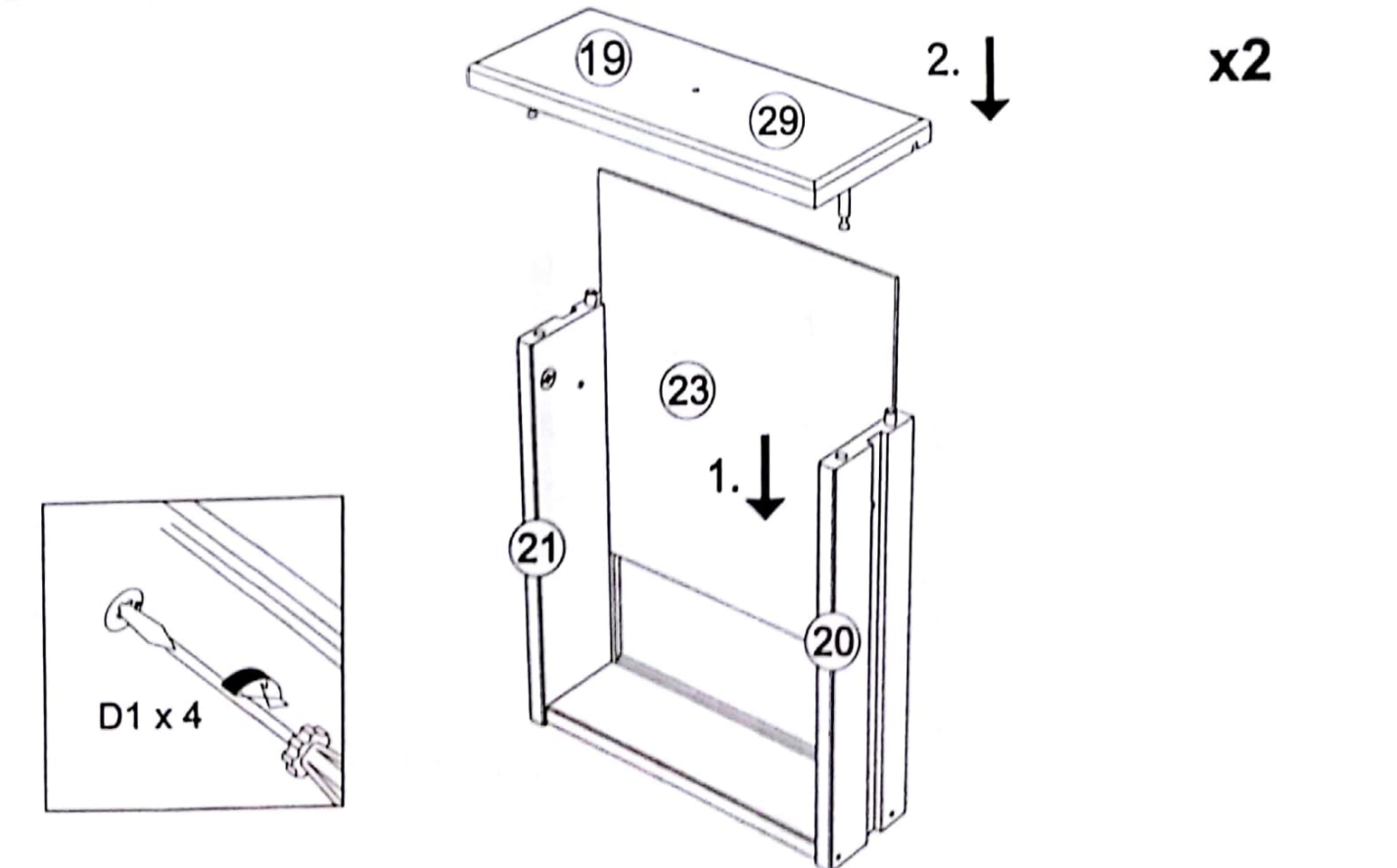
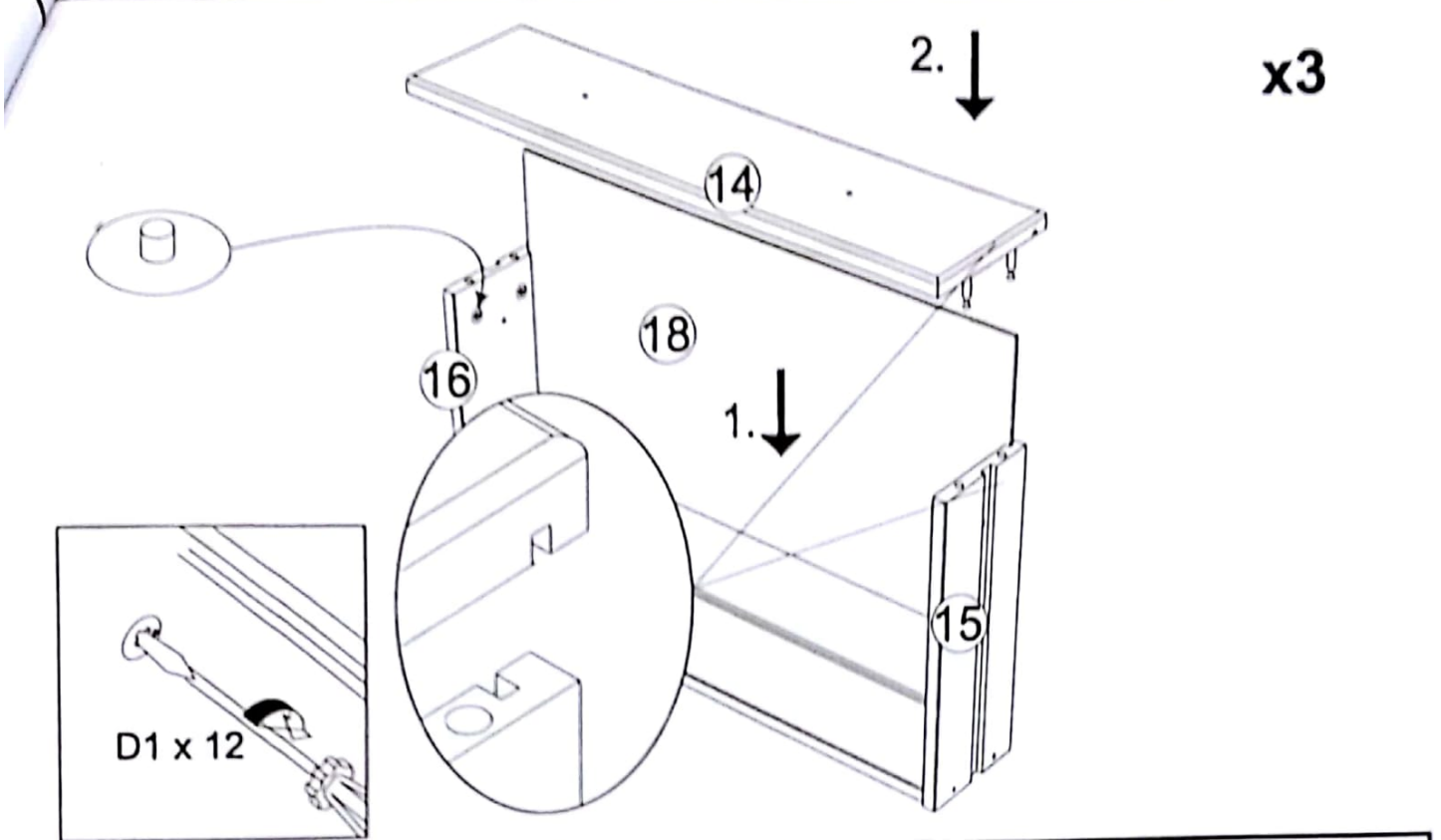
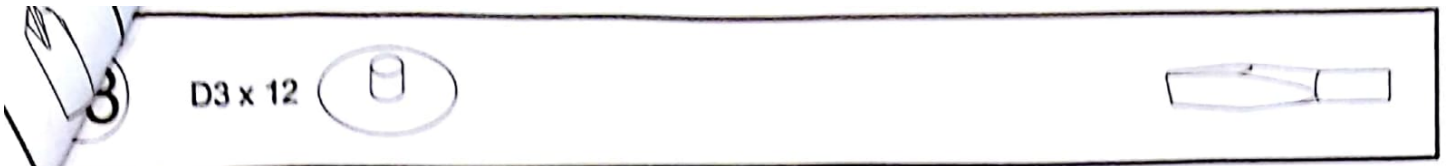

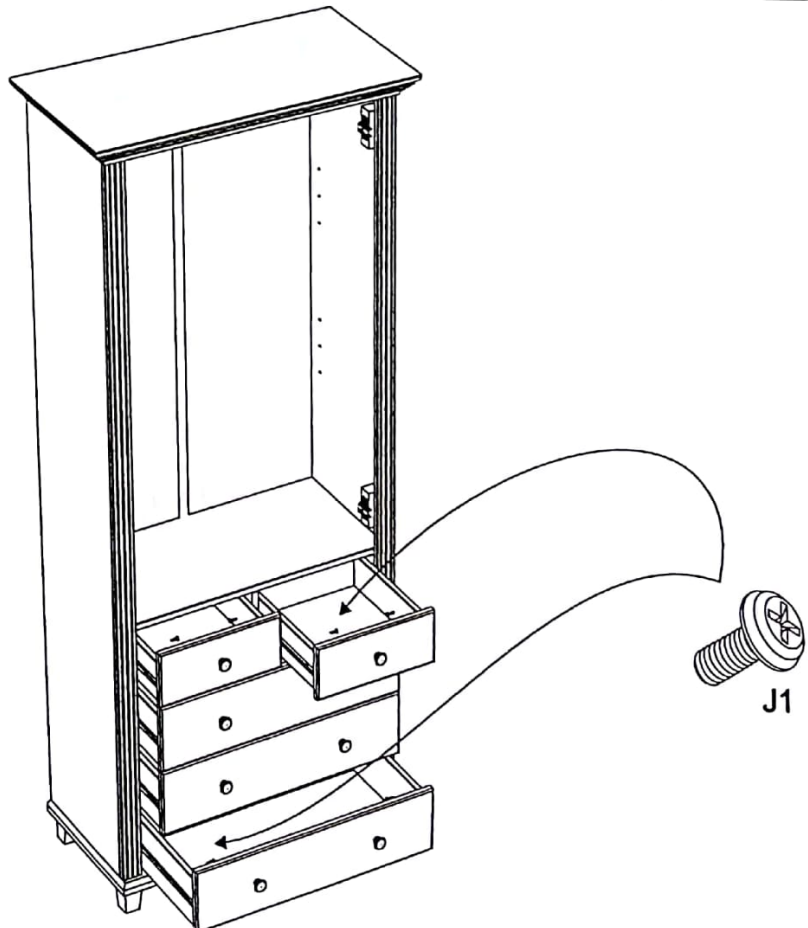
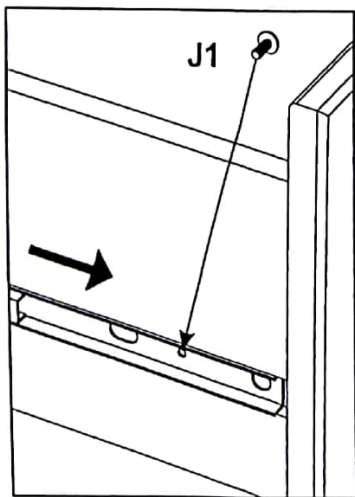
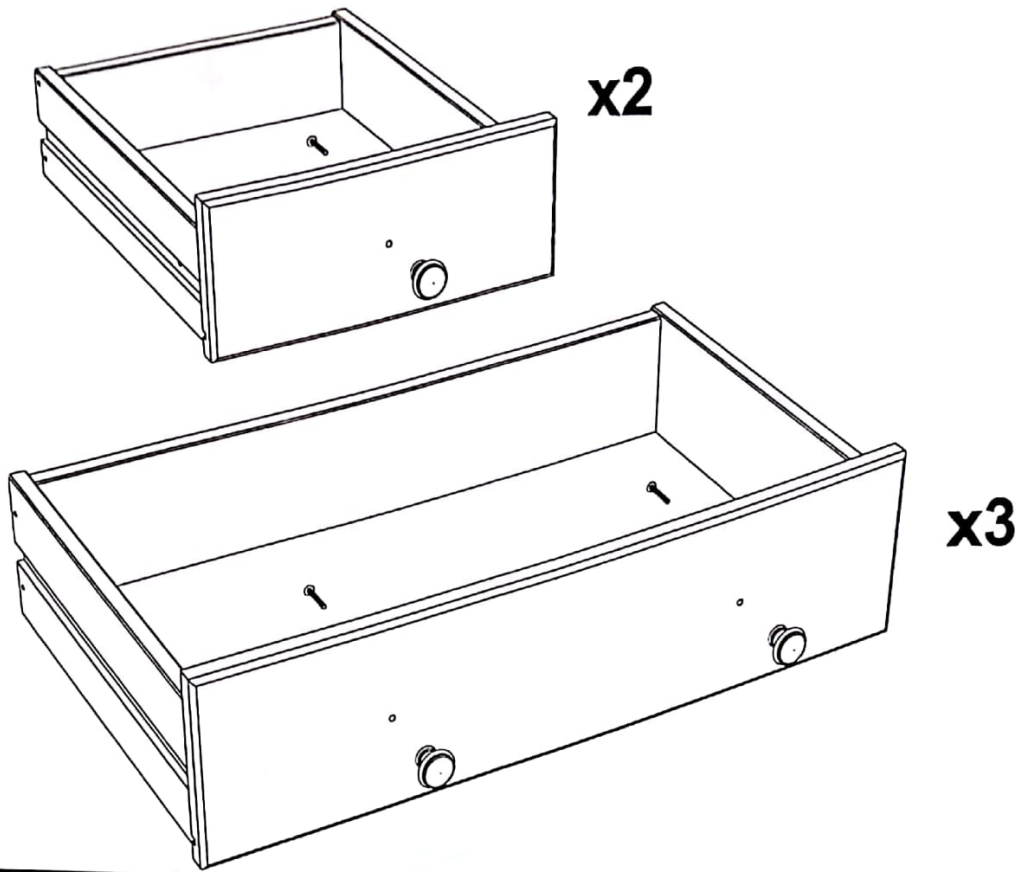

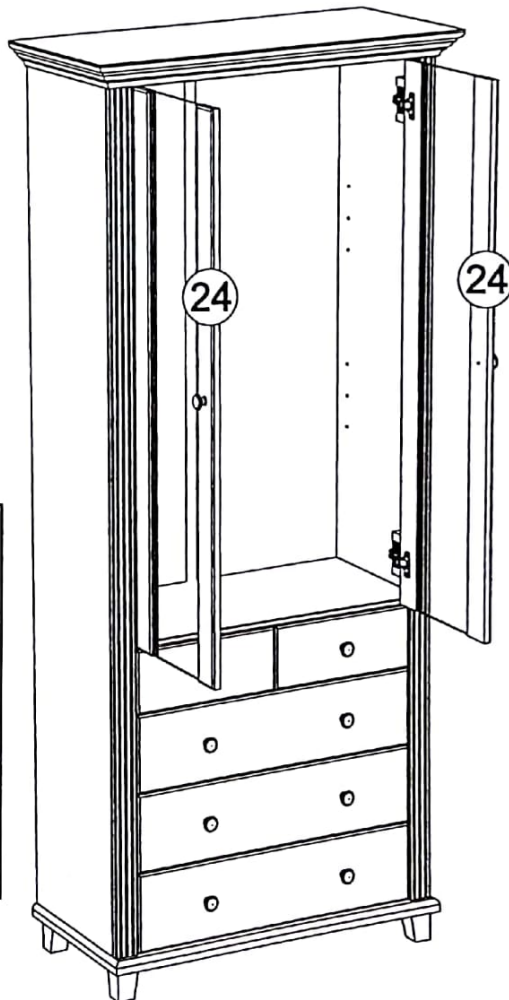
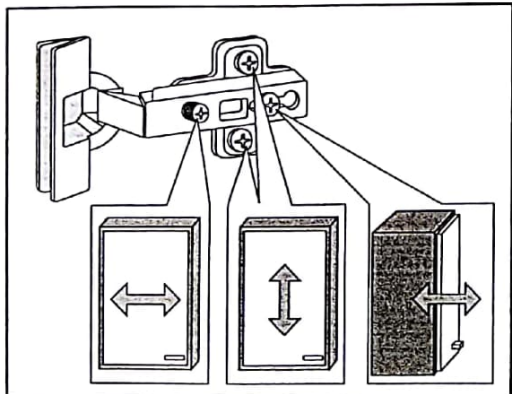
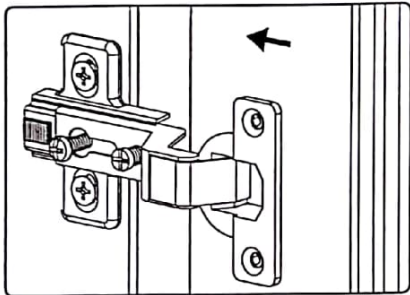
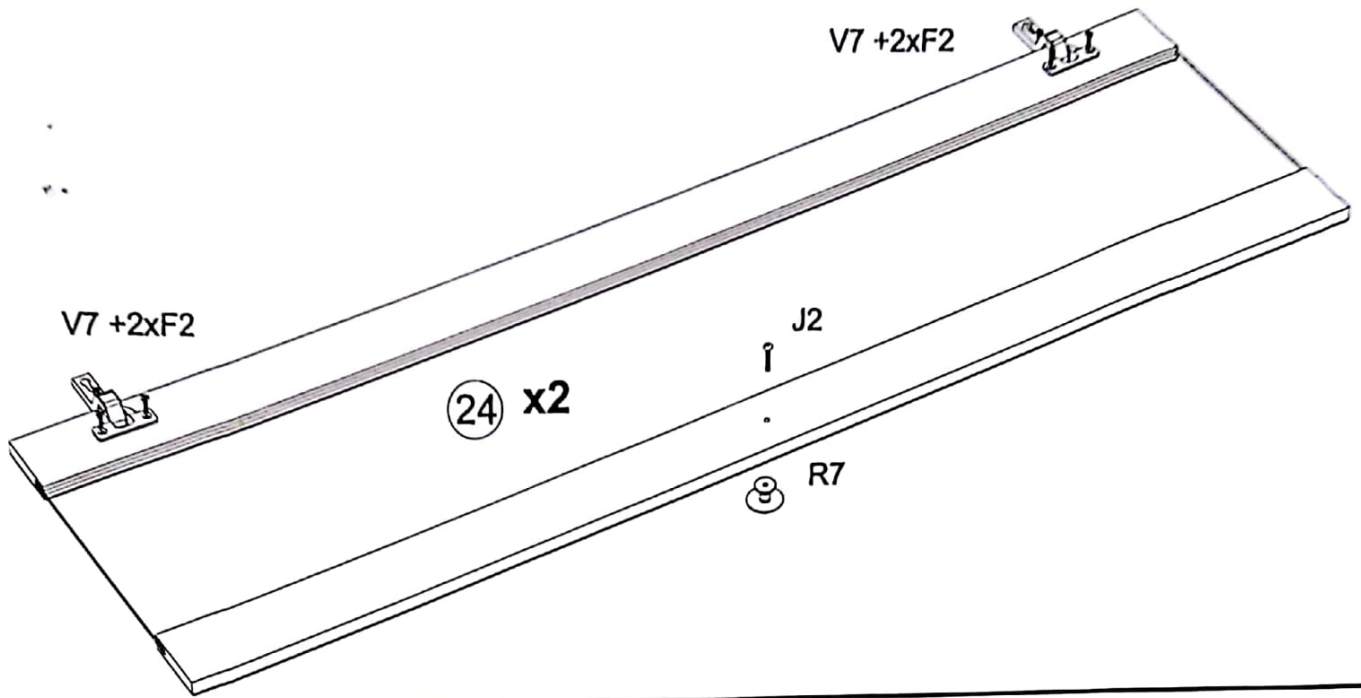
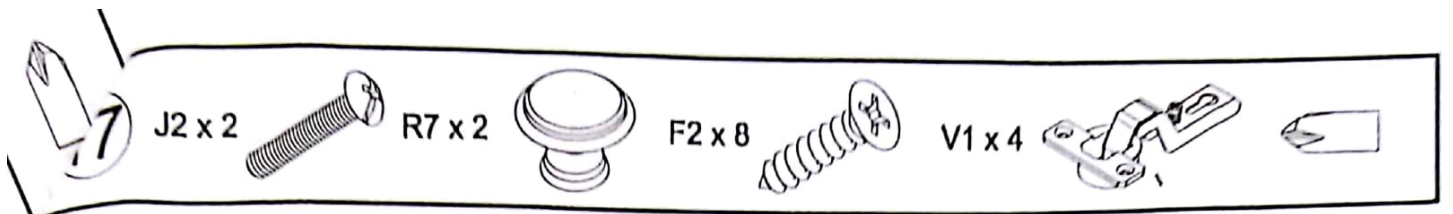

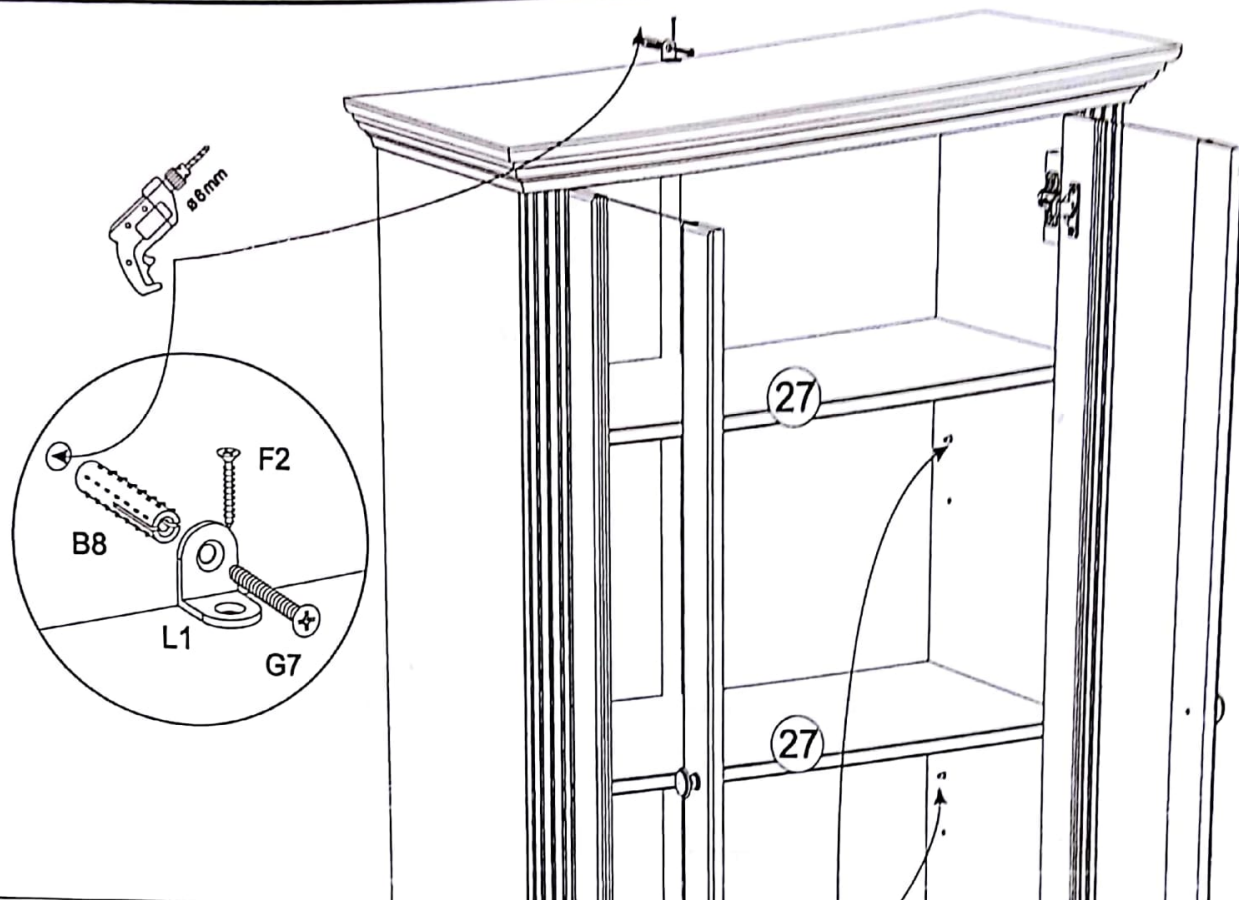
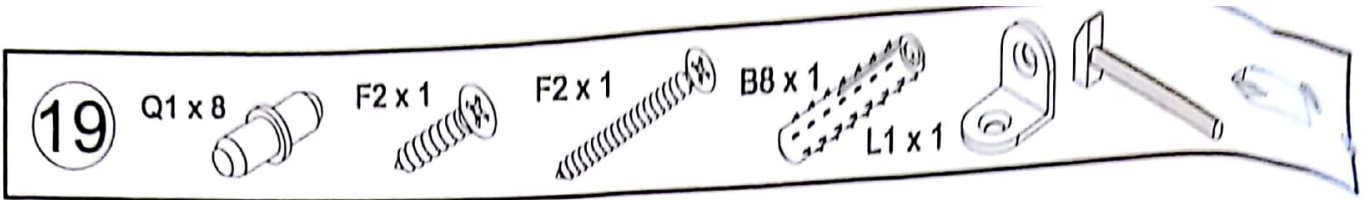

Achtung - Attention - Attenzione Opzelet - Uwaga - Pozor - Figyelem Atentie - Внимател - Внимание	
(D)	Wandbefestigung dient als Kippschutz – unbedingt anbringen! Bei einigen Wandtypen kann ein Spezialdübel erforderlich sein!
(GB)	The wall fastening serves to prevent tipping – be absolutely sure to mount it! For certain wall types, a special wall plug may be necessary!
(FR)	La fixation murale sert de protection contre le basculement – à installer impérativement ! Pour certains types de murs il faut des chevilles spéciales !
(IT)	Il fissaggio alla parete serve da protezione anti-ribaltamento – attaccarla assolutamente! Per alcune strutture di parete può essere necessario un tassello speciale!
(NL)	Bevestiging aan de muur dient als kantelbescherming – zeker en vast bevestigen! Bij enkele muurtypen is een speciale plug misschien vereist!
(PL)	Mocowanie do ściany jest jednocześnie zabezpieczeniem przed przewróceniem – koniecznie zamontować! Do niektórych rodzajów ścian koniecznie zastosować specjalne kolki mocujące.
(CZ)	Montáž na stěnu slouží jako ochrana proti převrnutí – bezpodmínečně umístěte! U některých typů stěn může být zapotřebí speciální hmoždinka!
(SK)	Upevnenie na stenu slúži ako ochrana proti prevráteniu – bezpodmínečne použite! Pre niektoré druhy stien môže byť potrebná špeciálna hmoždinka!
(HU)	A termék a falhoz kel rögzítési, különböző felborulhat! Egyes fal típusoknál speciális táplót kell használni!
(RO)	Sistemul de fixare la perete servește ca protecție la răsturnare – de montat obligatoriu! Pentru unele tipuri de pereți este posibil să fie necesar un diblu special!
(TR)	Duvardaki sabitleme, devrilmeye karşı bir emniyet tedbiridir ve mutlaka monte edilmelidir! Bazı duvar tiplerinde bunun için özel dibel gereklidir!
(RU)	Обязательно установите крепление на стене во избежание опрокидывания! Для некоторых типов стен может потребоваться специальный дюбель!

