

Nr	Ausmaß		St	Colli	
1	940	279	15	1	1
2	940	279	15	1	1
3	888	253	15	1	1
4	888	253	15	1	1
5	1370	273	15	1	2
6	1370	278	15	1	2
7	350	253	15	1	2
8	495	253	15	2	2
9	379	336	15	1	1
10	488	672	15	1	1
11	601	513	15	1	1
12	601	336	15	1	1
13	525	488	15	1	1
14	418	672	15	1	1
15	314	85	6	1	1
16	921	55	6	1	1
17	485	85	6	1	1
18	998	55	6	1	1
19	527	85	6	1	1
20	350	253	15	1	2
21	495	253	15	2	2
22	902	364	2	1	1
23	902	509	2	1	1
24	902	509	2	1	1

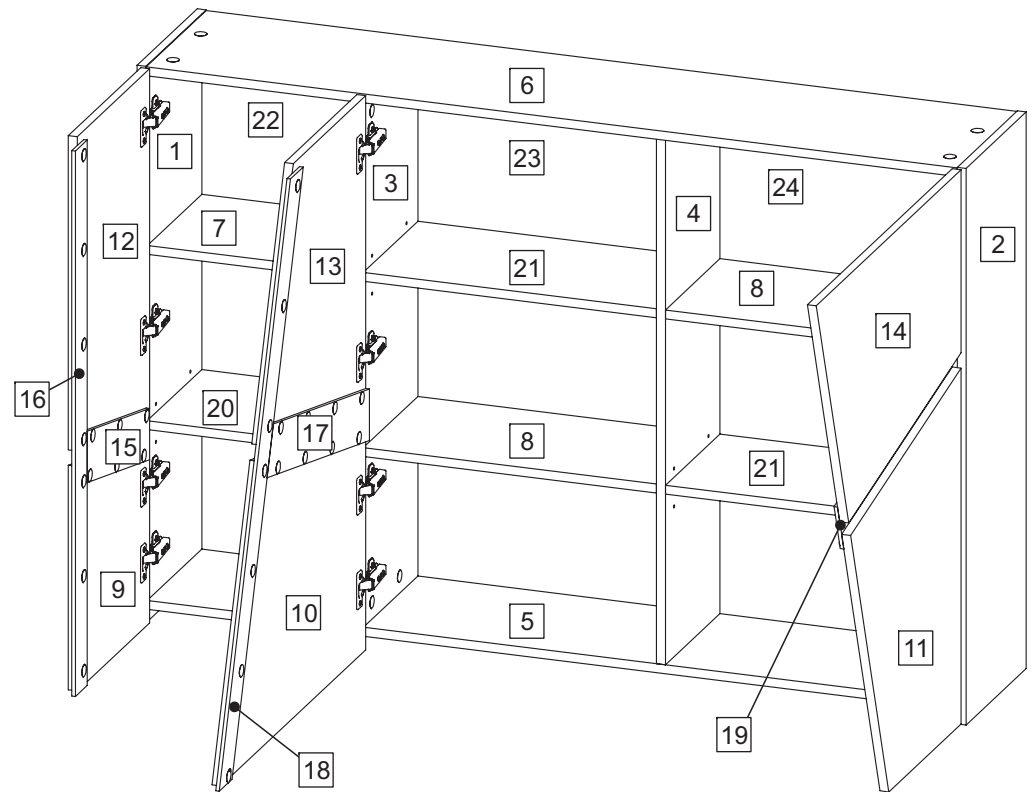

0 10 20 30 40 50 60 70 80 90 100 110 120 130 140 150 160 170 180 190 200



1

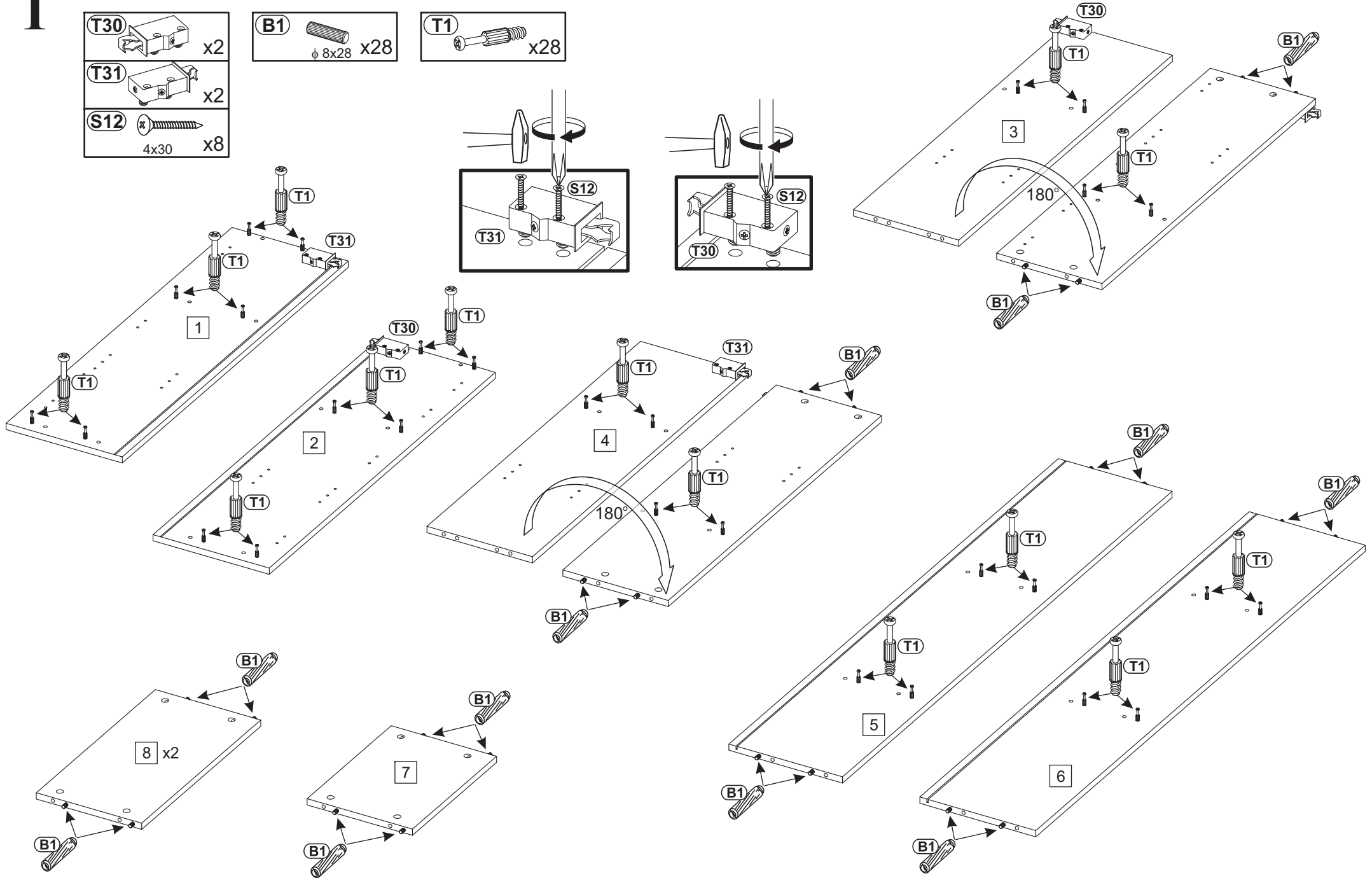
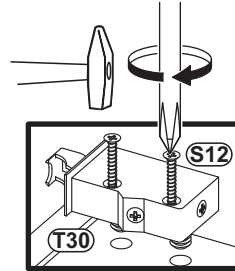
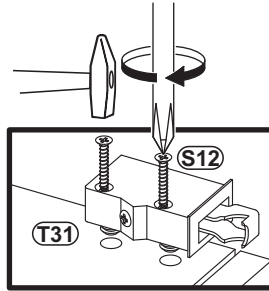
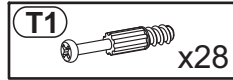
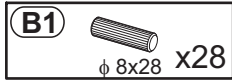
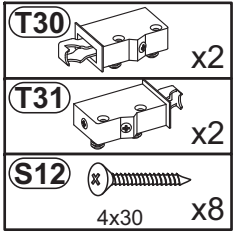

2

- Z2 x6
- Z2c x6
- S8 4x13 x24

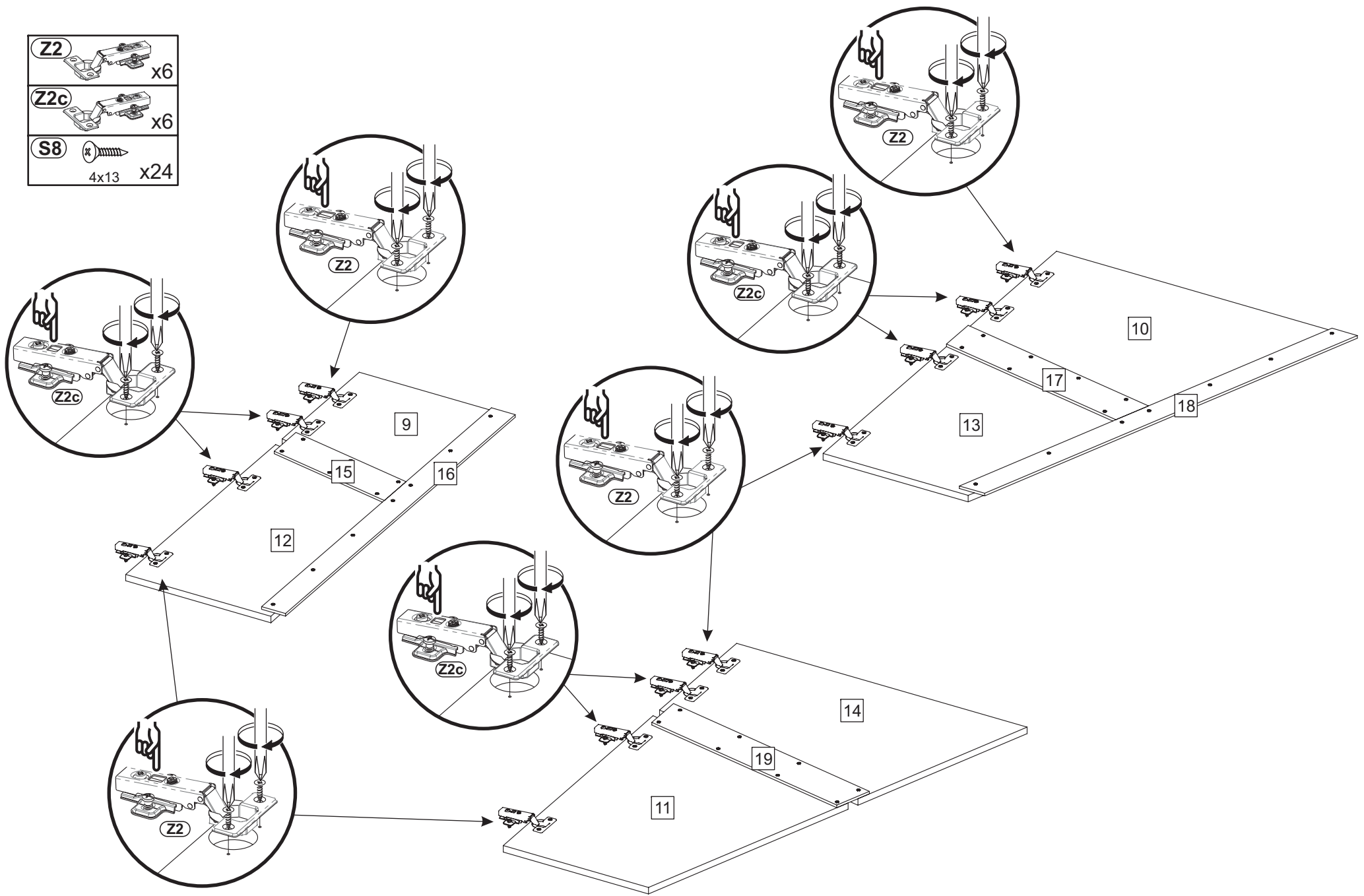

3

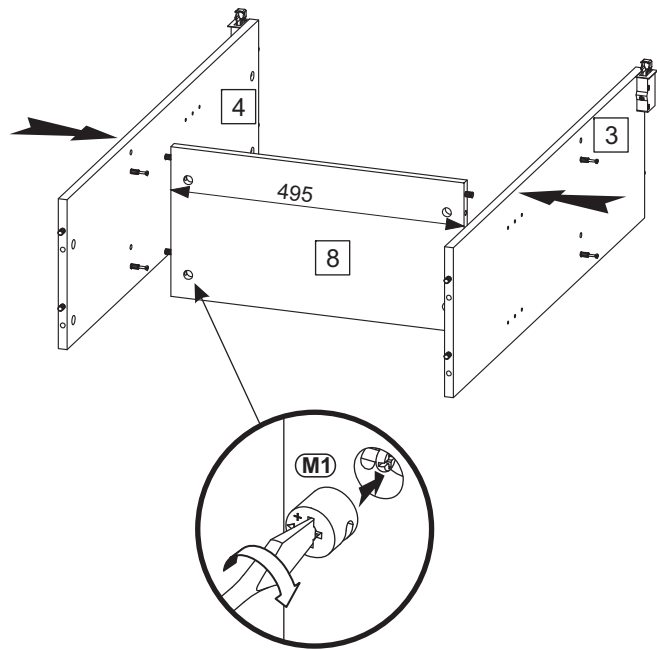

4

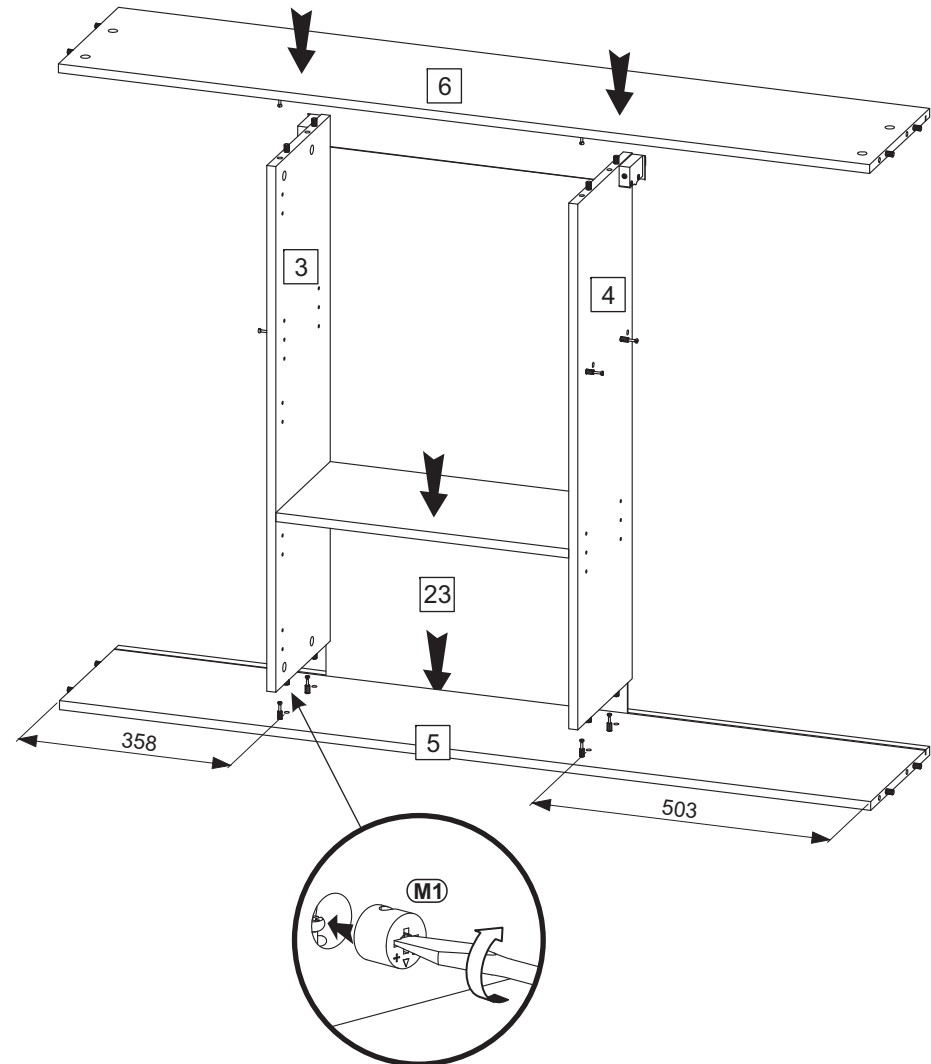

5

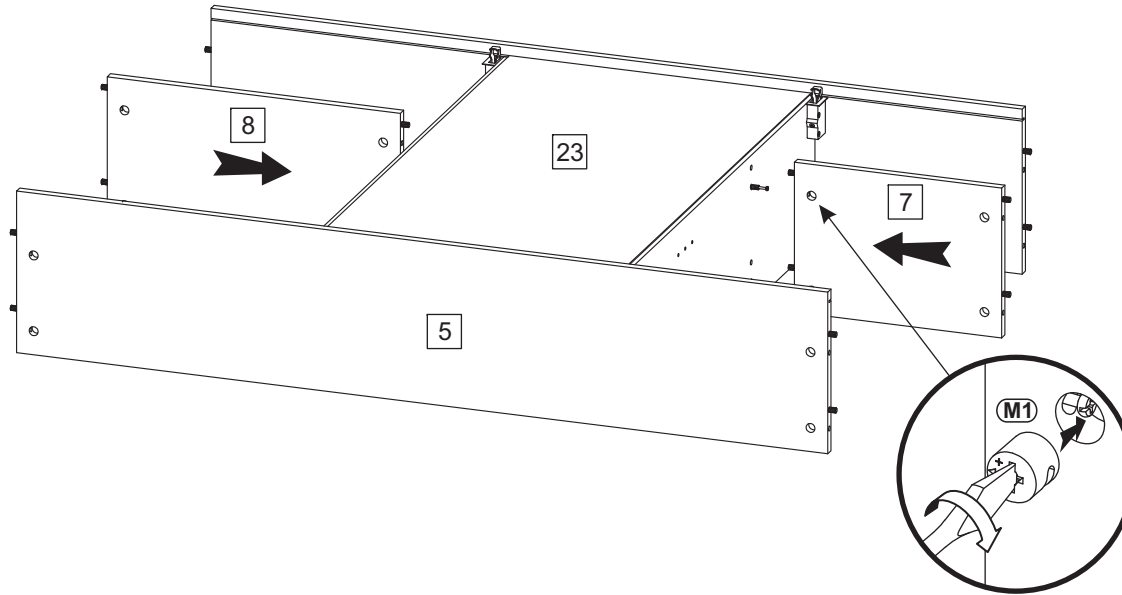

6

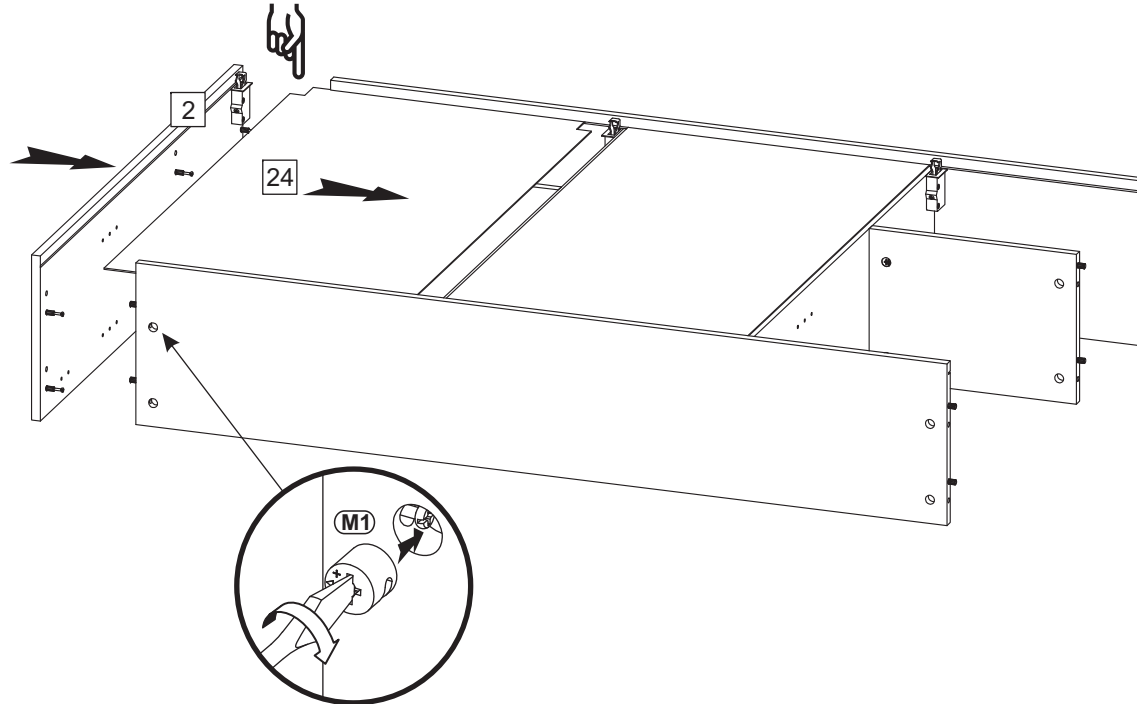

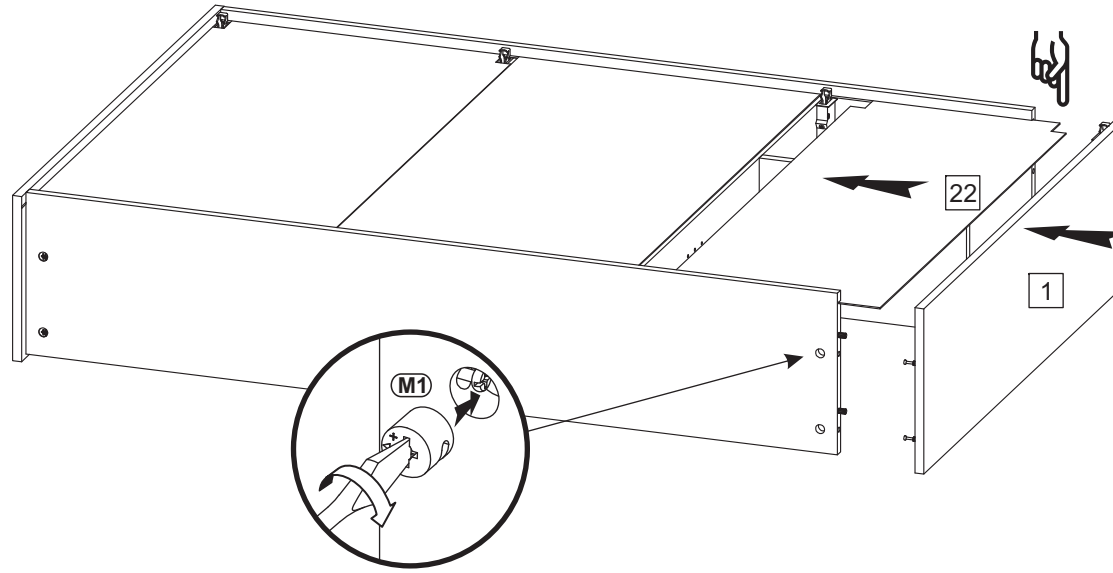

7

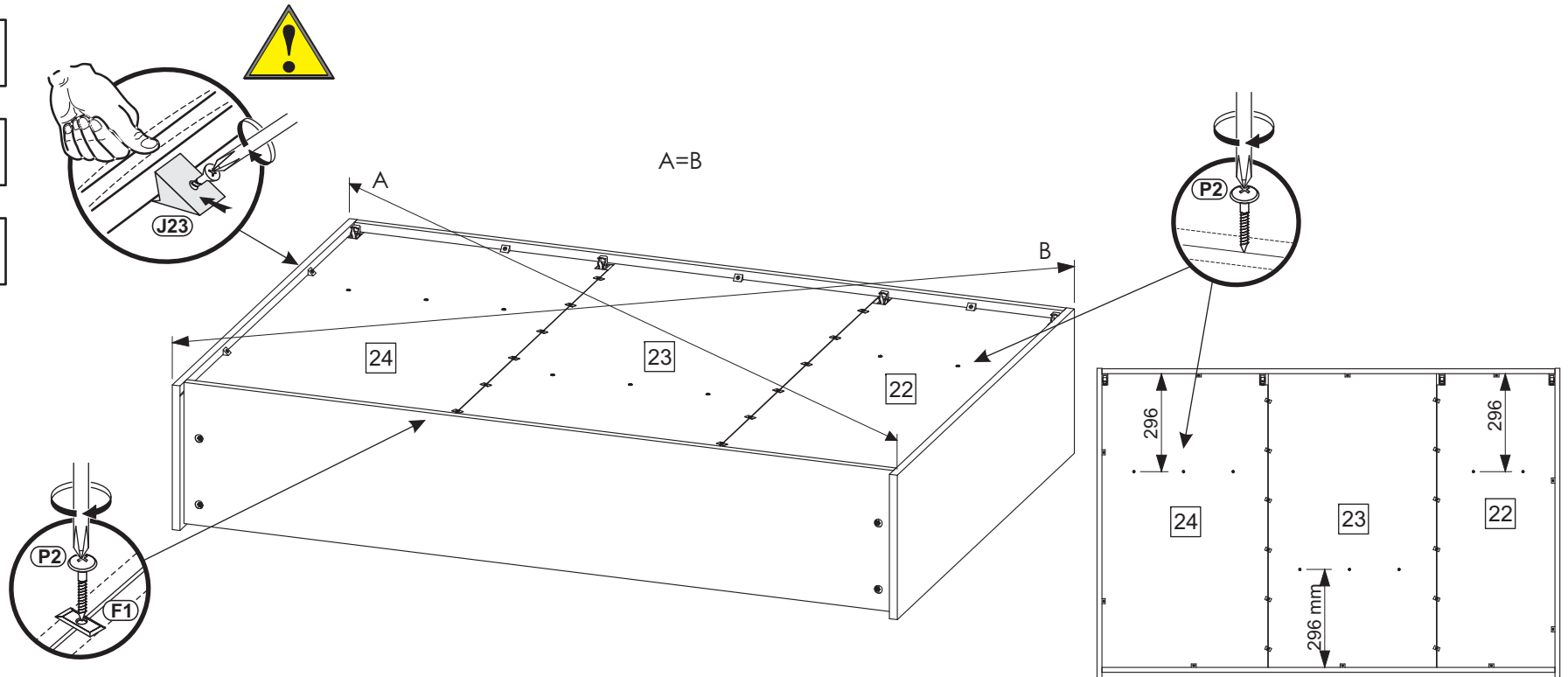
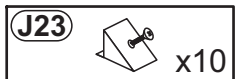
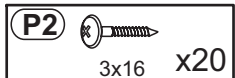
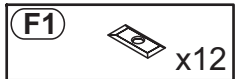

8



9

- F33**  x4
- T17** $\phi 8 \times 50$
5x60  x8

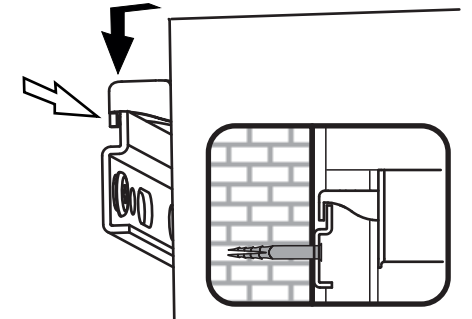
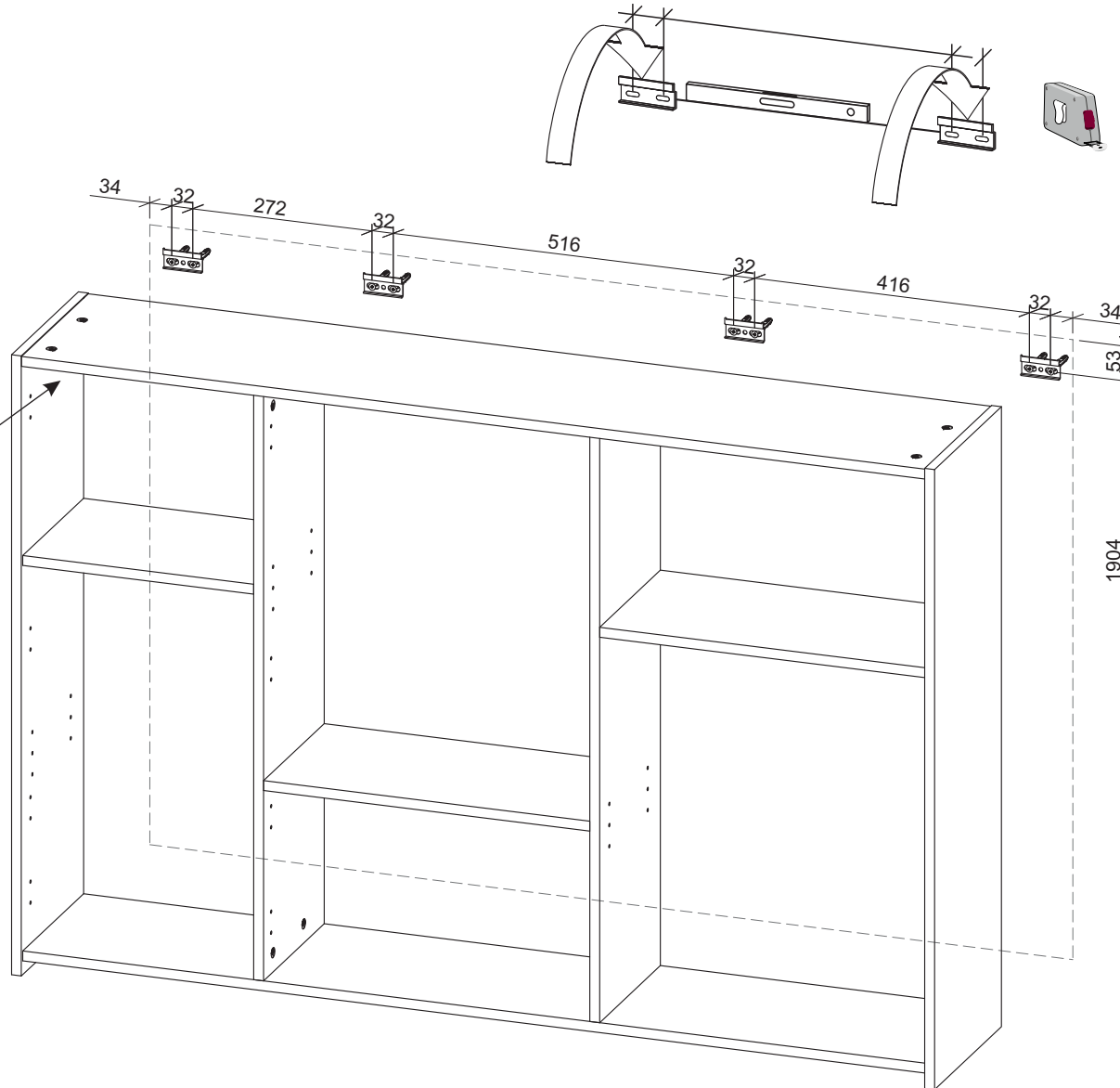
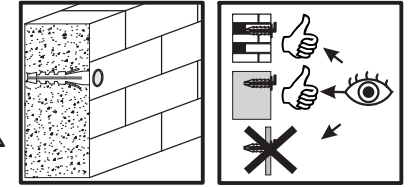
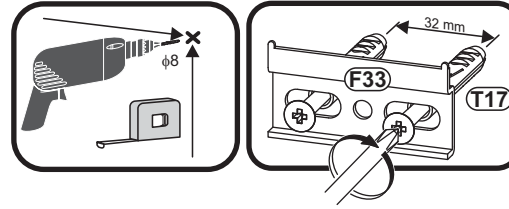

10

