

# 2347LISU

PARISOT S.A.S. , 70800 ST LOUP SUR SEMOUSE -FRANCE-

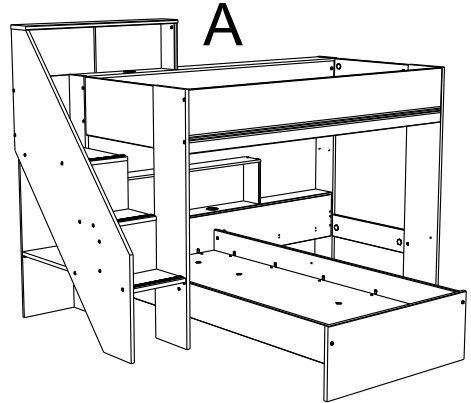

- FR** LE COUCHAGE EN HAUTEUR NE CONVIENT PAS AUX ENFANTS DE MOINS DE 6 ANS  
**EN** THE TOP BUNK IS NOT RECOMMENDED FOR CHILDREN UNDER 6  
**DE** HOCHBETTEN SIND NICHT FÜR KINDER UNTER 6 JAHREN GEEIGNET  
**ES** NO SE RECOMIENDA ACOSTAR A NIÑOS MENORES DE 6 AÑOS EN ALTO  
**PT** AS CAMAS EM ALTURA NÃO SÃO APROPRIADAS PARA CRIANÇAS COM MENOS DE 6 ANOS  
**IT** IL PIANO SUPERIORE DEI LETTI A CASTELLO NON È ADATTO AI BAMBINI DI ETÀ INFERIORE AI 6 ANNI  
**NL** HOOGSLAPERS ZIJN NIET GESCHIKT VOOR KINDEREN ONDER DE 6 JAAR  
**CZ** LEŽENÍ VE VÝŠCE NENÍ VHODNÉ PRO DĚTI DO 6 LET  
**HU** A FELSŐ FEKVŐHELY NEM ALKALMAS 6 ÉVEN ALULI GYERMEK SZÁMÁRA.  
**PL** SPANIE NA GÓRZE NIE JEST DOZWOLONE DLA DZIECI PONIŻEJ 6 ROKU ŻYCIA  
**RO** PATUL ÎNALT NU ESTE RECOMANDAT PENTRU COPIII MAI MICI DE 6 ANI  
**RU** СОН НА ВЕРХНЕМ ЯРУСЕ НЕ РАЗРЕШАЕТСЯ ДЕТЯМ ДО 6 ЛЕТ  
**SK** V HORNEJ ČASTI NESMÚ SPAŤ DETI MLADŠIE AKO 6 ROKOV  
**TR** 6 YAŞINDAN KÜÇÜK ÇOCUKLARIN ÜST TARAFTA YATMASI UYGUN DEĞİLDİR  
 النوم في السرير العلوي لا يناسب الأطفال الذين تقل أعمارهم عن 6 أعوام.

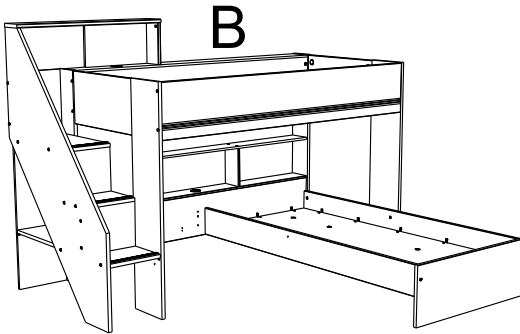

## FR Remerciements :

Nous vous remercions d'avoir choisi un meuble créé et fabriqué par le Groupe Parisot et espérons qu'il vous donnera entière satisfaction.

## EN Thanks:

Thank you for choosing furniture designed and manufactured by the Parisot Group. We hope you are totally satisfied with your purchase.

## DE Danksagung:

Wir danken Ihnen für den Kauf eines Frankreich von der Parisot-Gruppe entworfenen und hergestellten Möbelstücks und hoffen, dass Sie es zu Ihrer vollkommenen Zufriedenheit finden werden.

## ES Agradecimientos:

Les damos las gracias por haber elegido un mueble diseñado y fabricado por el Groupe Parisot y esperamos que sea de su total agrado.

## PT Agradecimentos:

Obrigado por ter escolhido um móvel concebido e fabricado pelo Grupo Parisot, esperando que seja do seu inteiro agrado.

## IT Ringraziamenti:

Grazie per avere scelto un mobile progettato e fabbricato dal Gruppo Parisot. Speriamo soddisfisi appieno le vostre esigenze.

## NL Bedankje:

Wij bedanken u voor de aankoop van een door de Groep Parisot ontworpen en vervaardigd meubel en hopen dat u er veel plezier aan zult beleven.

## CZ Poděkování:

Děkujeme, že jste si vybrali nábytek navržený a vyrobený společností Parisot Group. Doufáme, že budete svým nákupem naprosto spokojeni.

## HU Köszönet:

Köszönjük, hogy a Parisot Groupe által létrehozott és gyártott bútort választott, reméljük, hogy elégedett lesz a termékkel.

## PL Podziękowania:

Dziękujemy za wybór mebli stworzonych i wyprodukowanych przez Grupę Parisot. Mamy nadzieję, że będziecie Państwo w pełni zadowoleni z zakupu.

## RO Mulțumiri:

Vă mulțumim că ați ales un articol de mobilier conceput și fabricat de Grupul Parisot și sperăm că veți fi pe deplin satisfăcuți de acesta.

## RU Благодарность:

Мы благодарим вас за то, что вы выбрали мебель, созданную и произведенную Групп Паризо, и надеемся, что вы будете полностью удовлетворены нашей продукцией.

## SK Pod'akovanie:

Ďakujeme, že ste si vybrali nábytok navrhnutý a vyrobený spoločnosťou Parisot Group. Dúfame, že budete svojím nákupom absolútne spokojní.

## TR Teşekkür ederiz:

Parisot Group tarafından tasarlanan ve üretilen bu mobilyayı seçtiğiniz için teşekkür ederiz. Ürünümüzden memnun kalmanızı ümit ederiz.

## AR : شكر

نشكركم لاختياركم هذه القطعة من الأثاث من تصميم وتصنيع مجموعة باريسو Parisot ونتمنى أن تتال رضائكم.

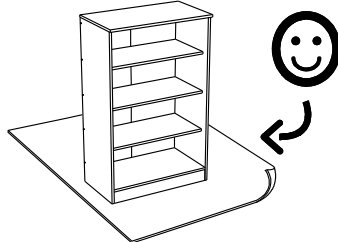
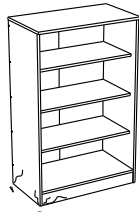
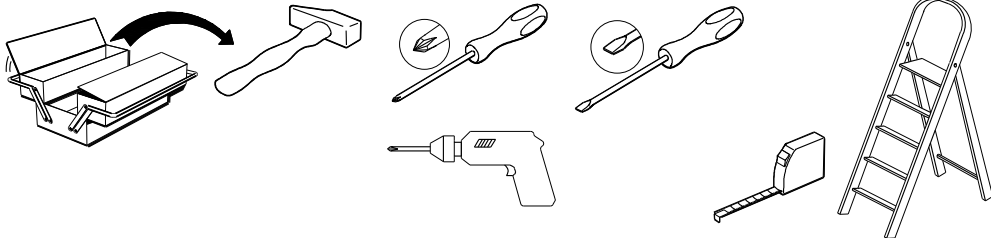

[contact@parisot.com](mailto:contact@parisot.com)

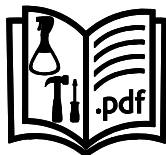

[www.parisot.com](http://www.parisot.com)

## FR. Instructions d'utilisation

### IMPORTANT – LIRE ATTENTIVEMENT – A CONSERVER POUR RÉFÉRENCE ULTÉRIEURE

- a) **AVERTISSEMENT** Les lits surélevés et le lit supérieur des lits superposés ne conviennent pas pour les enfants de moins de six ans en raison du risque de blessures liées à des chutes,
- b) **AVERTISSEMENT** S'ils ne sont pas utilisés correctement, les lits superposés et les lits surélevés peuvent présenter un sérieux risque de blessure par étranglement. Ne jamais attacher ou suspendre des éléments à des parties du lit superposé qui ne sont pas destinés à être utilisés avec ledit lit. Ces éléments comprennent, sans toutefois s'y limiter, les cordes, les ficelles, les cordons, les crochets, les ceintures et les sacs,
- c) **AVERTISSEMENT** Les enfants peuvent se retrouver coincés entre le lit et un mur, une partie d'un toit incliné, le plafond, des meubles adjacents (par exemple, des placards) ou autre. Pour éviter tout risque de blessure grave, la distance entre la barrière de sécurité supérieure et les éléments environnants ne doit pas dépasser 75 mm ou doit être supérieure à 230 mm,
- d) **AVERTISSEMENT** Ne pas utiliser le lit superposé ou le lit surélevé si une pièce de la structure est manquante ou cassée. Les pièces de rechange doivent être demandés auprès du fabricant ou du magasin.
- e) Il est impératif de toujours suivre les instructions de montage et d'utilisation du fabricant,
- f) La taille recommandée du matelas à utiliser avec le lit est de 2000mm x 900mm, **Epaisseur du matelas maximum : 150mm,**
- g) Il est nécessaire de ventiler la pièce afin de maintenir un niveau peu élevé d'humidité et d'empêcher le développement de moisissure dans le lit et sa périphérie,
- k) Les dispositifs d'assemblage doivent toujours être convenablement serrés et régulièrement vérifiés. Les resserrer si nécessaire.
- l) Conforme aux exigences européenne de sécurité de la norme NF EN 747+A1 : 2015.
- m) la présence d'une veilleuse de nuit peut procurer plus de sécurité à l'enfant couchant dans le lit haut

## EN - Instructions for use

### IMPORTANT – READ CAREFULLY – KEEP FOR FUTURE REFERENCE

- a) **WARNING** Raised beds and the upper bed in a bunk bed assembly are not good for children under 6 years old because of the risk of injury from falling from such beds,
- b) **WARNING** If the raised and bunk beds are not used correctly, they can present a serious risk of injury from strangulation. Never attach or suspend things from the upper bunk bed that are not going to be used with that bed. Such things include - but are not limited to - cords, string, sashes, hooks, belts and bags.
- c) **WARNING** Children can find themselves trapped between the bed and wall, or inclined roof wall, ceiling, adjacent pieces of furniture (such as cupboards) or other items. To avoid any risk of serious injury, the distance between the upper safety barrier and surrounding items should not exceed 75 mm - or the distance should be greater than 230 mm.
- d) **WARNING** Do not use the upper bunk bed or a raised bed if a part of the structure is missing or broken. Spare parts should be requested from the manufacturer or shop.
- e) It is essential that the manufacturer's instructions on assembly and use are followed.
- f) The recommended size of the mattress to be used with the bed is 2000mm x 900mm, **Maximum mattress thickness: 150mm,**
- g) Mattresses must be aired to maintain a low humidity and to stop moisture building up in the bed and its surroundings.
- k) The fastenings put in place on assembly should all be properly tightened and regularly checked. Retighten the fastenings as necessary.
- l) This complies with the requirements of the European Safety Standard NF EN 747+A1: 2015.
- m) The presence of a night light could give more safety for a child sleeping in an upper bed.

### WICHTIG - AUFMERKSAM LESEN - ZUR SPÄTEREN EINSICHTNAHME AUFZUBEWAHREN

- a) **WARNUNG** Hochbetten und das obere Bett bei Etagenbetten sind wegen des Verletzungsrisikos durch Stürze nicht für Kinder unter sechs Jahren geeignet.
- b) **WARNUNG** Wenn sie nicht richtig verwendet werden, können Hochbetten und Etagenbetten ein schweres Verletzungsrisiko durch Strangulierung darstellen. Es dürfen niemals Elemente an Teilen des Hochbetts befestigt oder aufgehängt werden, die nicht zur Verwendung mit besagtem Bett bestimmt sind. Diese Elemente umfassen, sind aber nicht beschränkt auf, Seile, Fäden, Schnüre, Haken, Gürtel und Taschen.
- c) **WARNUNG** Kinder können sich zwischen dem Bett und einer Wand, einer gekippten Wandstelle, der Decke, Möbeln in der Nähe (zum Beispiel Schränke) oder anderem einklemmen. Um jedes Risiko einer schweren Verletzung zu vermeiden, darf der Abstand zwischen der oberen Sicherheitsschranke und den Elementen in der Umgebung 75 mm nicht überschreiten oder muss größer als 230 mm sein.
- d) **WARNUNG** Das Hochbett oder das Etagenbett darf nicht verwendet werden, wenn ein Teil des Aufbaus fehlt oder beschädigt ist. Ersatzteile müssen beim Hersteller oder im Laden bestellt werden.
- e) Die Montage- und Gebrauchsanweisungen des Herstellers müssen unbedingt immer befolgt werden.
- f) Die empfohlene Größe der mit dem Bett zu verwendenden Matratze beträgt 2000 mm x 900 mm. **Höchststärke der Matratze: 150 mm.**
- g) Es ist notwendig, den Raum zu lüften, um einen geringen Feuchtigkeitsgrad aufrechtzuerhalten und die Entwicklung von Schimmel im Bett und seiner Umgebung zu verhindern.
- k) Die Montagevorrichtungen müssen immer angemessen festgezogen und regelmäßig überprüft werden. Wenn nötig, erneut festziehen.
- l) Entspricht den europäischen Sicherheitsanforderungen der Norm NF EN 747+A1 : 2015.
- m) Wenn ein Nachtlicht vorhanden ist, kann dies dem im oberen Bett schlafenden Kind mehr Sicherheit geben.

## ES - Instrucciones de empleo

### IMPORTANTE – LEER CON ATENCIÓN –CONSERVAR PARA FUTURAS REFERENCIAS

- a) **ADVERTENCIA** Las camas elevadas y la cama superior de las literas no son convenientes para niños menores de seis años debido al riesgo de lesiones por caída.
- b) **ADVERTENCIA** Si no se emplean correctamente, las camas elevadas y las literas podrían presentar riesgo de lesiones por estrangulación. No enganche o suspenda elementos a las partes de la litera que no estén destinadas a emplearse con la cama. Estos elementos pueden ser, sin que por ello la lista sea limitativa, cuerdas, cintas, cordones, ganchos, cinturones y bolsas,
- c) **ADVERTENCIA** Los niños podrían quedar atrapados entre la cama y la pared, una parte del techo inclinada, el techo, muebles adyacentes (armarios por ejemplo) u otros. Para evitar cualquier riesgo de lesión grave, la distancia entre la barrera de seguridad superior y los elementos que la rodean no deberán superar los 75 mm o ser superiores a 230 mm,
- d) **ADVERTENCIA** No utilice una litera o cama elevada si una pieza de la estructura falta o está dañada. Las piezas de recambio deberán solicitarse al fabricante o a la tienda.
- e) Siempre será obligatorio seguir las instrucciones de montaje y empleo del fabricante,
- f) El tamaño del colchón recomendado para la cama es de 2000mm x 900mm, **Espesor máximo del colchón: 150mm,**
- g) También será necesario ventilar la habitación para mantener un nivel de humedad poco elevado y evitar el desarrollo de mohos en la cama y su entorno,
- k) Los dispositivos de ensamblaje deberán apretarse de manera adecuada y comprobarse regularmente. Apretarlos si fuera necesario
- l) Cumple los requisitos europeos de seguridad de la norma NF EN 747+A1: 2015.
- m) una luz de noche ofrecerá más seguridad al niño que duerma en la cama superior.

## PT - Instruções de utilização

### IMPORTANTE – LER ATENTAMENTE – A GUARDAR PARA REFERÊNCIA FUTURA

- a) **AVISO** As camas sobre-elevadas e a cama superior dos beliches não são adaptadas para as crianças menores de seis anos devido ao risco de ferimentos ligados a quedas,
- b) **AVISO** Se não forem utilizados corretamente, os beliches e as camas sobre-elevadas podem apresentar um sério risco de ferimento por estrangulamento. Nunca amarrar ou suspender elementos em partes do beliche que não estão destinadas para ser utilizados com a dita cama. Estes elementos incluem, não sendo esta lista exaustiva, as cordas, os fios, os cordões, os ganchos, os cintos e os sacos,
- c) **AVISO** As crianças podem ficar bloqueadas entre a cama e uma parede, uma parte de um telhado inclinado, o teto, móveis adjacentes (por exemplo, armários) ou outro. Para evitar qualquer risco de ferimento grave, a distância entre a barreira de segurança superior e os elementos circundantes não deve ultrapassar 75 mm ou deve ser superior a 230 mm,
- d) **AVISO** Não utilizar o beliche ou a cama sobre-elevada se faltar uma peça da estrutura ou se uma peça estiver partida. As peças sobressalentes devem ser pedidas ao fabricante ou à loja.
- e) É obrigatório seguir sempre as instruções de montagem e de utilização do fabricante,
- f) O tamanho recomendado do colchão a utilizar com a cama é de 2000mm x 900mm, **Espessura do colchão máximo: 150mm**,
- g) É necessário ventilar a peça de forma a manter um nível mais elevado de humidade e de impedir o desenvolvimento de bolor na cama e na sua periferia,
- k) Os dispositivos de montagem devem estar sempre apertados e regularmente verificados. Apertá-los se necessário.
- l) Conforme às exigências europeias de segurança da norma NF EN 747+A1 : 2015.
- m) A presença de uma luz de presença pode dar mais segurança à criança que estiver a dormir na cama de cima

## IT - Istruzioni per l'uso

### IMPORTANTE – LEGGERE ATTENTAMENTE – DA CONSERVARE PER UN'ULTERIORE CONSULTAZIONE

- a) **AVVERTENZE** I letti a soppalco ed il letto superiore dei letti a castello non sono adatti ai bambini di età inferiore ai sei anni per i rischi di lesioni dovute a cadute,
- b) **AVVERTENZE** Se non utilizzati correttamente, i letti a castello ed i letti a soppalco possono rappresentare un importante rischio di lesioni da strangolamento. Non legare o sospendere mai elementi a delle parti del letto a castello che non siano previsti per essere utilizzati con il suddetto letto. Questi elementi comprendono, senza tuttavia esserne limitati, le corde, gli spaghi, i cordoncini, i ganci, le cinghie ed i sacchi,
- c) **AVVERTENZE** I bambini possono ritrovarsi bloccati tra il letto ed un muro, la parte di un tetto inclinato, il soffitto, i mobili adiacenti (per esempio gli armadi) o altro. Per evitare qualsiasi rischio di lesione grave, la distanza tra la sponda di sicurezza superiore e gli elementi circostanti non deve superare 75 mm o deve essere superiore a 230 mm,
- d) **AVVERTENZE** Non utilizzare il letto a castello o il letto a soppalco se un pezzo della struttura manca o se è rotto. I pezzi di ricambio devono essere richiesti al fabbricante o al negozio.
- e) Seguire rigorosamente le istruzioni di montaggio e d'uso del fabbricante,
- f) La misura consigliata del materasso da usare con il letto è di 2000mm x 900mm, **Spessore massimo del materasso: 150mm**,
- g) Per mantenere un livello poco elevato di umidità, e per impedire lo sviluppo di muffa nel letto e intorno al letto, ventilare la stanza,
- k) I dispositivi d'assemblaggio devono sempre essere adeguatamente stretti e regolarmente verificati. Ristringerti se necessario.
- l) Conforme alle esigenze europee di sicurezza della norma NF EN 747+A1: 2015.
- m) la presenza di una luce notturna può dare più sicurezza al bambino che dorme nel letto superiore

### BELANGRIJK – AANDACHTIG LEZEN – TE BEWAREN VOOR LATERE RAADPLEGING

- a) **WAARSCHUWING** De verhoogde bedden en het hoge bed van stapelbedden zijn niet geschikt voor kinderen jongeren dan zes omwille van het gevaar op kwetsuren door valpartijen,
- b) **WAARSCHUWING** Wanneer ze niet correct gebruikt worden, kunnen verhoogde bedden en stapelbedden een ernstig gevaar inhouden op kwetsuren door wurging. Nooit dingen bevestigen of ophangen aan delen van het stapelbed die niet bestemd zijn voor gebruik met het desbetreffende bed. Deze elementen omvatten, zonder hiertoe beperkt te zijn, koorden, touwen, snoeren, haken, riemen en zakken of tassen,
- c) **WAARSCHUWING** Kinderen kunnen vast komen te zitten tussen het bed en een muur, een deel van het hellend dak, het plafond, naburige meubels (bijvoorbeeld kasten) of andere zaken. Om elk gevaar op een ernstige kwetsuur te vermijden, mag de afstand tussen de bovenste veiligheidsstang en de omliggende elementen niet groter zijn dan 75 mm of moet deze groter zijn dan 230 mm,
- d) **WAARSCHUWING** Het verhoogde bed of stapelbed niet gebruiken wanneer een onderdeel van de structuur ontbreekt of defect is. De vervangstukken moeten bij de fabrikant of winkel besteld worden.
- e) U moet steeds de montage- en gebruiksrichtlijnen van de fabrikant volgen,
- f) De aanbevolen afmeting van de bij het bed te gebruiken matras is 2000mm x 900mm. **Maximale dikte van de matras: 150mm,**
- g) U moet de ruimte goed verluchten om de vochtigheidsgraad te beperken en schimmelvorming in het bed en zijn omgeving te vermijden,
- k) De assemblageonderdelen moeten steeds goed vastgezet zijn en regelmatig gecontroleerd worden. Deze indien nodig aanspannen.
- l) Conform de Europese veiligheidseisen van de norm NF EN 747+A1: 2015.
- m) Een nachtlampje kan het kind in het bovenste bed meer veiligheid bieden.

## CZ - Pokyny k použití

### DŮLEŽITÉ – POZORNĚ PROČTĚTE – UCHOVEJTE PRO POZDĚJŠÍ POTŘEBU

- a) **VAROVÁNÍ** Vyvýšené postele a horní postel patrových postelí nejsou určeny pro děti mladší šesti let z důvodu rizika poranění způsobeného pádem,
- b) **VAROVÁNÍ** V případě nesprávného používání mohou vyvýšené a patrové postele představovat vážné riziko poranění úskrcením. Nikdy nepřivazujte ani nezavěšujte na patrovou postel či její část předměty, které nejsou určeny k použití společně s patrovou postelí. Jedná se především a nejen o lana, provazy, šňůry, pásky a sáčky,
- c) **VAROVÁNÍ** Děti se mohou ocitnout zablokované mezi postelí a stěnou, stropem, sousedícím nábytkem (například skříněmi) či jinými elementy. Pro zamezení veškerých rizik vážného zranění nesmí vzdálenost mezi horní zábranou a okolními prvky přesáhnout 75 mm anebo být vyšší než 230 mm,
- d) **VAROVÁNÍ** Nepoužívejte patrovou nebo vyvýšenou postel s chybějící nebo poškozenou konstrukcí. Náhradní díly musí být objednány u výrobce anebo v příslušném obchodě,
- e) Je bezpodmínečně nutné vždy postupovat podle pokynů montáže a pokynů k použití uvedených výrobcem,
- f) Doporučená velikost matrace pro použití s touto postelí je 2000mm x 900mm, **Maximální tloušťka matrace: 150mm,**
- g) Je nutné větrat místnost a udržovat tím nízký stupeň vlhkosti a zamezit vzniku plísně v posteli a v jejím okolí,
- k) Prvky montáže musí být vždy správně utaženy a pravidelně kontrolovány. Je-li to potřeba, utáhněte je,
- l) Odpovídá evropským požadavkům bezpečnostní normy NF EN 747+A1 : 2015,
- m) Přítomnost noční lampačky může přinést větší pocit bezpečí dítěte spícího na horní posteli.

### FONTOS! OLVASSA EL FIGYELMESEN, ÉS ŐRIZZE MEG KÉSŐBBI HASZNÁLATRA

- a) **FIGYELEM!** A magasított ágyak és az emeletes ágyak felső ágai nem alkalmasak hat évesnél fiatalabb gyermekek számára, mert az esetleges leesés sérüléseket okozhat,
- b) **FIGYELEM!** Nem megfelelő használat esetén az emeletes ágyak és a magasított ágyak komoly fulladásveszélyt jelentenek. Soha ne kötözzön és ne függessen az emeletes ágy részeire olyan tárgyakat, amelyek nem az adott ágy használatához tartoznak. A teljesség igénye nélkül, ilyen tárgyak lehetnek kötelek, zsinórok, vezetékek, horgok, övek, táskák,
- c) **FIGYELEM!** A gyermekek beszorulhatnak az ágy és a fal, a tetőtéri dőlt mennyezet, a mennyezet, a mellette lévő bútorok (például szekrények), vagy egyéb elemek közé. A súlyos sérülések elkerülése érdekében a felső biztonsági korlát és a mellette lévő elemek közötti távolságnak 75 mm-nél kisebbnek, vagy 230 mm-nél nagyobbak kell lennie
- d) **FIGYELEM!** Ne használja az emeletes ágyat vagy a magasított ágyat akkor, ha a szerkezet egy eleme hiányzik, vagy törött. A cserealkatrészeket a gyártótól vagy az üzletben kell megrendelni.
- e) A gyártó szerelési és használati előírásait mindig be kell tartani,
- f) Az ágygal használandó matrac ajánlott mérete 2000 mm x 900 mm, **A matrac vastagsága maximum: 150 mm,**
- g) A helyiséget szellőztetni kell az alacsony páratartalom fenntartása érdekében, hogy megelőzze a penész kialakulását az ágyon és a környékén,
- k) Az összeszerelésre szolgáló alkatrészeket mindig szorosan meg kell húzni és rendszeresen ellenőrizni kell. Szükség esetén ismét meg kell szorítani őket.
- l) Megfelel az NF EN 747+A1:2015 szabvány európai biztonsági követelményeinek.
- m) Éjszakai lámpa használata a felső ágyon alvó gyermek számára nagyobb biztonságot nyújthat

## PL - Instrukcja obsługi

### WAŻNE - PRZECZYTAJ UWAGAŃNIE - ZACHOWAJ DO PÓŹNIEJSZEGO WGLĄDU

- a) **OSTRZEŻENIE** Łóżka piętrowe pojedyncze oraz łózko górne w łózkach piętrowych nie nadają się dla dzieci poniżej szóstego roku życia ze względu na niebezpieczeństwo obrażeń ciała związanych z upadkiem,
- b) **OSTRZEŻENIE** W przypadku nieprawidłowego używania łóżek piętrowych podwójnych i pojedynczych, mogą one stwarzać poważne niebezpieczeństwo obrażeń ciała związanych z uwięzieniem. Nigdy nie należy przyczepiać, ani zawieszać elementów do części górnego łóżka, które nie są przystosowane do właśnie takiego użycia. Elementy te to, nie ograniczając się do wymienionych, linki, wstążki, sznurki, haczyki, paski i torby,
- c) **OSTRZEŻENIE** Dzieci mogą zaklinować się między łóżkiem i ścianą, pochyloną częścią dachu, sufitem, przyległymi meblami (na przykład szafą) lub innym elementem konstrukcji. Aby uniknąć poważnych obrażeń ciała, odległość między górną barierką zabezpieczającą, a elementem sąsiadującym, nie może przekraczać 75 mm, lub musi być większa niż 230 mm,
- d) **OSTRZEŻENIE** Nie używać górnego łóżka lub pojedynczego łóżka piętrowego, jeżeli brakuje jednego z elementów konstrukcyjnych lub jest on zniszczony. Części zamienne należy zamawiać u producenta lub w sklepie.
- e) Należy przestrzegać instrukcji montażu i obsługi, dołączonej przez producenta,
- f) Zalecany rozmiar materaca pasującego do tego łóżka to 2000 mm x 900 mm, **Maksymalna grubość materaca: 150 mm,**
- g) Należy wietrzyć pomieszczenie, aby utrzymać wilgotność powietrza na średnim poziomie i uniknąć rozwoju pleśni w łózku i w jego okolicy,
- k) Elementy montażowe muszą być odpowiednio dokręcone i systematycznie sprawdzane. Dokręcić w razie potrzeby.
- l) Zgodnie z europejskimi wymogami bezpieczeństwa normy NF EN 747+A1: 2015.
- m) pozostawienie włączonej lampki nocnej może zwiększyć bezpieczeństwo dziecka śpiącego na górnym łózku

**IMPORTANT – CITITI CU ATENȚIE – a se păstra pentru referința ulterioară**

- a) **AVERTISMENT** Paturile înalte și patul de sus de la paturile suprapuse nu sunt potrivite pentru copiii sub șase ani din cauza riscului de leziuni legate de căderi
- b) **AVERTISMENT** În cazul în care nu sunt utilizate în mod corect, paturile suprapuse și paturile înalte pot prezenta un risc grav de rănire prin strangulare. Nu atașați sau nu puneți obiecte pe părțile patului supraetajat care nu sunt destinate utilizării patului spus. Acești factori includ, dar nu se limitează la, frânghii, sfori, cordoane, cârlige, curele și genti
- c) **AVERTIZARE** Copiii pot fi blocați între pat și perete, o parte a unui acoperiș înclinat, tavan, mobilier adiacente înclinate (de exemplu, dulapuri) sau altele. Pentru a evita orice risc de rănire gravă, distanța dintre bariera de securitate superioară și elementele din jur nu trebuie să depășească 75 mm sau să fie mai mare de 230 mm
- d) **AVERTISMENT** Nu utilizați patul înalt sau patul suprapus, dacă lipsește o parte a structurii sau dacă e ruptă. Piesele de schimb trebuie să fie cerute fabricantului sau magazinului.
- e) Este imperativ să urmăriți întotdeauna instrucțiunile de instalare și de montaj ale fabricantului
- f) Dimensiunea recomandată a saltelei de utilizat pentru pat este de 2000mm x 900mm, **grosime maximală a saltelei: 150mm**
- g) Este necesar să aerisiți camera pentru a menține un nivel de umiditate scăzut și pentru a preveni dezvoltarea mușcăiului în pat și periferia sa
- k) Dispozitivele de asamblare trebuie să fie întotdeauna strânse în mod corect și verificate în mod regulat. Strângeți-le din nou dacă este necesar.
- l) Conform exigentelor europene de securitate NF EN 747 + A1: 2015.
- m) prezența unei veioze de noapte poate oferi un plus de siguranță pentru copilul culcat în patul de sus

**RU - Инструкция по использованию**

**ВНИМАНИЕ – ВНИМАТЕЛЬНО ОЗНАКОМЬТЕСЬ – ХРАНИТЬ ДЛЯ БУДУЩЕГО ПОЛЬЗОВАНИЯ**

- a) **ПРЕДУПРЕЖДЕНИЕ** Приподнятые кровати и верхняя кровать многоярусной кровати не подходят для детей до шести лет в силу опасности получить травму при падении,
- b) **ПРЕДУПРЕЖДЕНИЕ** При неправильном использовании приподнятые и многоярусные кровати могут представлять серьезную опасность удушья. Запрещается привязывать или подвешивать к частям приподнятой кровати предметы, не предназначенные для использования с ней. Это, в частности, веревки, шнуры, крючки, пояса и сумки,
- c) **ПРЕДУПРЕЖДЕНИЕ** Дети могут оказаться зажатыми между кроватью и стеной, наклонной частью крыши, потолком, рядом расположенными предметами мебели (например, стенным шкафом) или иным предметом. Во избежание опасности тяжелой травмы, расстояние между верхним защитным барьером и окружающими элементами должно быть не более 75 мм или более 230 мм,
- d) **ПРЕДУПРЕЖДЕНИЕ** Запрещается использовать приподнятую или многоярусную кровать при недостающей или поврежденной ее детали. Запасные части следует заказывать только у изготовителя или в магазине.
- e) Следовать инструкции изготовителя по сборке и пользованию обязательно,
- f) Рекомендованный размер матраса для использования с кроватью составляет 2000 мм x 900 мм, **Максимальная толщина матраса: 150 мм**
- g) Необходимо проветривать спальню для поддержания незначительного уровня влажности во избежание появления плесени на кровати и вокруг нее,
- k) Крепежные детали следует тщательно затягивать и регулярно проверять. При необходимости подтянуть.
- l) Соответствует Европейскому стандарту безопасности NF EN 747+A1 : 2015
- m) наличие ночника может создать больший комфорт для ребенка, спящего в верхней кровати



## SK - Pokyny k použitiu

### DOLEŽITÉ – POZORNE PREČÍTAJTE – USCHOVEJTE PRE PŘÍPADNÚ POTREBU

- a) **VAROVANIE** Vyvýšené postele a vrchná posteľ poschodových postelí nie sú určené pre deti do šiesti let z dôvodu rizika poranenia zapríčineného pádom,
- b) **VAROVANIE** V prípade nesprávneho použitia môžu vyvýšené a poschodové postele predstavovať vážne riziko poranenia úškrtami. Nikdy nepriväzujte ani nezavesujte na poschodovú posteľ či jej časť predmety, ktoré nie sú určené k použitiu spolu s poschodovou postelí. Jedná sa predovšetkým a nielen o lana, špagáty, šnúry, pásky a vrecká,
- c) **VAROVANIE** Deti sa môžu ocitnúť zablokované medzi posteľou a stenou, stropom, susediacim nábytkom (napríklad skriňami) či inými prvkami. Pre zamedzenie všetkých rizík vážneho zranenia nesmi vzdialenosť medzi hornou zábranou a vedľajšími prvkami presiahnuť 75 mm alebo byť vyššia 230 mm,
- d) **VAROVANIE** Nepoužívajte poschodovú alebo vyvýšenú posteľ s chýbajúcou alebo poškodenou konštrukciou. Náhradné diely je nutné objednávať u výrobcu alebo v príslušnom obchode,
- e) Je bezpodmienečne nutné postupovať vždy podľa pokynov montáže a pokynov k použitiu uvedených výrobcom,
- f) Odporúčaná veľkosť matrace pre použitie s posteľou je 2000mm x 900mm, **Maximálna hrúbka matrace: 150mm**,
- g) Je nutné vetrať miestnosť a udržiavať tak nízky stupeň vlhkosti a zamedziť vznik plesní v posteli a v okolí,
- k) Prvky montáže musí byť vždy správne utiahnuté a pravidelne kontrolované. Ak je treba, pritiahnete ich,
- l) Odpovedá európskym požiadavkám bezpečnostnej normy NF EN 747+A1 : 2015.
- m) Prítomnosť nočnej lampičky môže navodiť väčší pocit bezpečia dieťaťa spiacieho na hornej posteli

## TR - Kullanım talimatları

### ÖNEMLİ – DİKKATLE OKUYUNUZ – DAHA SONRA DA BAŞVURMAK İÇİN SAKLAYIN

- a) **UYARI** Yükseltilmiş yataklar ve çift katlı yatakların ikinci katı düşmeye bağlı yaralanma riskleri nedeniyle altı yaşından küçük çocuklar için uygun değildir.
- b) **UYARI** Yanlış kullanıldığında yükseltilmiş yataklar ve çift katlı yataklar ciddi bir boğaza dolanma yoluyla boğulma riski taşır. Çift katlı yatağa bu yatakla kullanılmayacak hiçbir öge bağlamayınız, sarkıtmayınız. Bu öğelere ip, organ, kordon, askı, kemer ve çantalar dâhildir ancak liste bunlarla sınırlı değildir.
- c) **UYARI** Çocuklar yatak ile duvar, eğimli bir çatının bir kısmı, tavan, yakında bulunan mobilyalar (örneğin dolaplar) ve diğer cisimler arasında sıkışabilir. Her türlü ciddi yaralanma riskini ortadan kaldırmak için güvenlik bariyeriyle çevrede bulunan öğeler arasındaki uzaklık 75 mm'den az veya 230 mm'den çok olmalıdır.
- d) **UYARI** Yapının bir parçası eksik veya kırıkta çift katlı yatağı veya yükseltilmiş yatağı kullanmayınız. Değiştirmek için gereken yedek parçalar imalatçıdan veya mağazalardan istenmelidir.
- e) İmalatçının montaj ve kullanım talimatlarına uymak büyük önem taşır.
- f) Yatakla kullanılacak şiltenin 2000 mm x 900 mm boyutlarında olması tavsiye edilir, **Maksimum şilte kalınlığı: 150 mm**
- g) Rutubeti düşük tutmak ve yatak ve çevresinde küflenmeyi önlemek için yatağı havalandırmak gereklidir.
- k) Montaj parçaları her zaman uygun bir biçimde sıkılmalı ve düzenli olarak kontrol edilmelidir. Gerektiğinde yeniden sıkılmalıdır.
- l) Avrupa NF EN 747+A1 : 2015 normunun güvenlik gerekliliklerine uygundur.
- m) Bir gece lambası bulunması üst yatakta yatan çocuk için daha fazla güvenlik sağlayabilir.

هام - الرجاء القراءة بتمعن - يرجى الاحتفاظ بهذا الدليل للمرجعية المستقبلية

- (أ) تحذير هام: الأسرة المرتفعة والسرير العلوي للأسرة بطابقين ليست مناسبة للأطفال دون سن ست سنوات بسبب مخاطر الإصابات المتعلقة بالسقوط.
- (ب) تحذير هام: إذا لم يتم استخدامها بشكل صحيح، فإن الأسرة بطابقين والأسرة المرتفعة قد تمثل خطرا جديا للإصابة بالخنق. لا تربط ولا تعلق أبدا عناصر إلى أجزاء من السرير بطابقين التي لم تخصص للاستخدام مع هذا السرير. وتشمل هذه العناصر على الحبال والخيوط والنطاقات والخطاطيف والأحزمة والحقائب.
- (ت) تحذير هام: يمكن للأطفال أن يحاصروا بين السرير والجدار أو جزء من سقف مائل أو السقف أو الأثاث المجاور (على سبيل المثال، خزانة) أو غير ذلك. ولتجنب إصابة خطيرة، يجب على المسافة بين حاجز السلامة العلوي والعناصر المحيطة أن لا تتجاوز 75 مم أو يجب أن تكون أكبر من 230 مم.
- (ث) تحذير هام: لا تستخدم السرير بطابقين أو السرير المرتفع إذا كان أي جزء من الهيكل مفقود أو مكسور. يجب طلب قطع الغيار من قبل الشركة المصنعة أو المحل التجاري.
- (ج) لا بد من إتباع دائما تعليمات التركيب والتشغيل للشركة المصنعة.
- (ح) حجم المرتبة الموصى بها لاستخدامها مع السرير هو 2000 مم X 900 مم، والحد الأقصى لسماكة المرتبة هو: 150 مم.
- (خ) من الضروري تهوية الغرفة للحفاظ على مستوى منخفض من الرطوبة ومنع نمو العفن في السرير ومحيطه
- (د) يجب دائما على عناصر التجميع أن يتم تشديدها بشكل صحيح وفحصها بانتظام. قم بتشديدها من جديد إذا لزم الأمر.
- (ذ) تلبى متطلبات السلامة الأوروبية لمعيار 2015 : NF EN 747+A1.
- (ر) وجود مصباح ليلي قد يوفر سلامة إضافية للطفل الذي يرقد في السرير المرتفع.

170.5cm  
67 1/4"  
241.5cm  
95 1/4"  
218.5cm  
86"

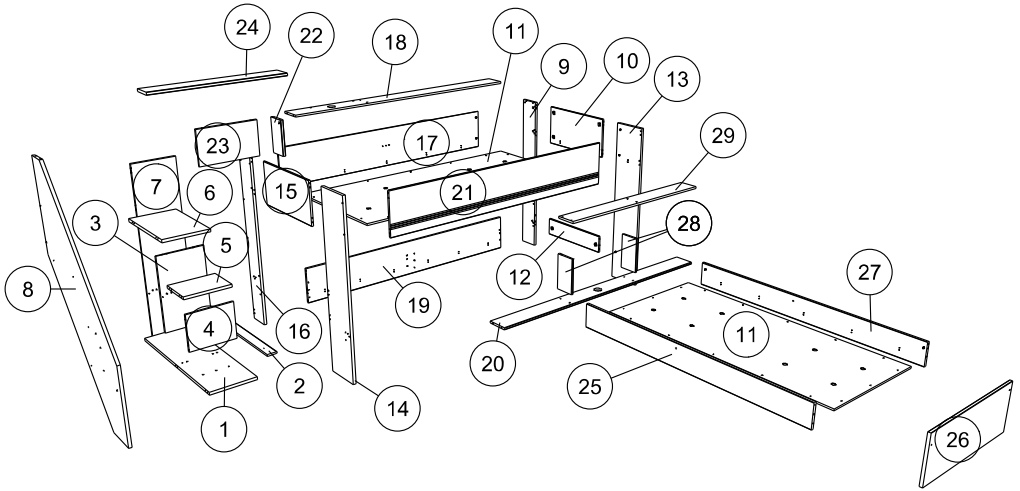

			mm			inch		
22	x	1	280	151	22	11	5 15/16	7/8
28	x	2	280	153	15	11	6	9/16
5	x	1	347	261	22	13 11/16	10 1/4	7/8
4	x	1	347	275	15	13 11/16	10 13/16	9/16
23	x	1	484	280	15	19 1/16	11	9/16
3	x	1	572	347	15	22 1/2	13 11/16	9/16
6	x	1	576	347	22	22 11/16	13 11/16	7/8
2	x	1	661	77	15	26	3	9/16
12	x	1	663	155	15	26 1/8	6 1/8	9/16
10	x	1	663	340	15	26 1/8	13 3/8	9/16
15	x	1	663	340	15	26 1/8	13 3/8	9/16
26	x	1	1006	371	22	39 5/8	14 5/8	7/8
24	x	1	1067	157	22	42	6 3/16	7/8
1	x	1	1092	347	22	43	13 11/16	7/8
29	x	1	1350	154	15	53 1/8	6 1/16	9/16
7	x	1	1403	347	15	55 1/4	13 11/16	9/16
9	x	1	1405	170	22	55 5/16	6 11/16	7/8
16	x	1	1405	170	22	55 5/16	6 11/16	7/8
13	x	1	1405	280	22	55 5/16	11	7/8
14	x	1	1405	280	22	55 5/16	11	7/8
11	x	2	1990	920	15	78 3/8	36 1/4	9/16
20	x	1	2000	159	15	78 3/4	6 1/4	9/16
18	x	1	2000	166	15	78 3/4	6 9/16	9/16
27	x	1	2000	193	22	78 3/4	7 5/8	7/8
25	x	1	2000	193	22	78 3/4	7 5/8	7/8
19	x	1	2000	295	15	78 3/4	11 5/8	9/16
17	x	1	2000	325	15	78 3/4	12 13/16	9/16
21	x	1	2000	340	15	78 3/4	13 3/8	9/16
8	x	1	2000	570	22	78 3/4	22 7/16	7/8

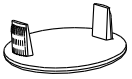

ADP x 10



AKG x 2



Ai x 16



ZF x 10

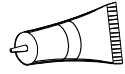

CF x 5

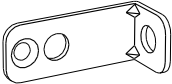

BLL x 2



VW x 10



CHK x 2



WA x 4



BAG x 11

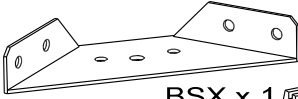

BSX x 1

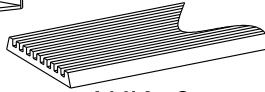

AHK x 3



AHX x 53

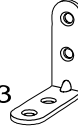

LN x 36

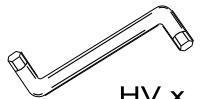

HV x 1

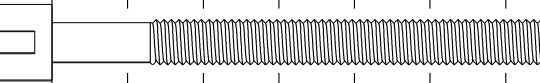
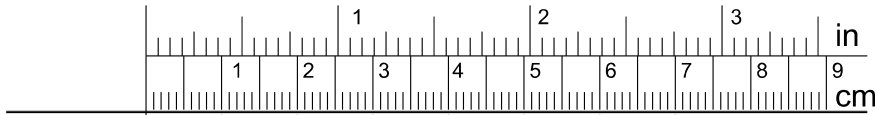

AiO x 10

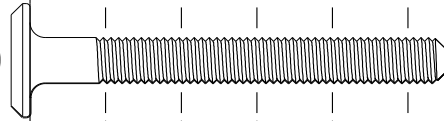
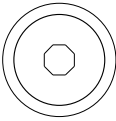

BLZ x 43

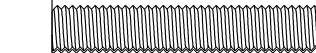

APU x 1

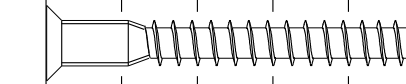

HW x 12

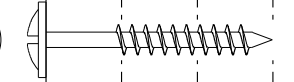
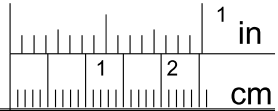

WH x 2

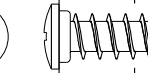

VB x 15

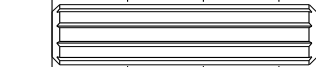

AP x 62



ANK x 8

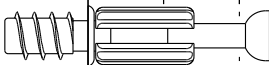

BSD x 16



Vi x 82



AKJ x 32

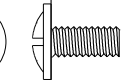

VR x 32

1



AP x 15



CF x 1



AHX x 13

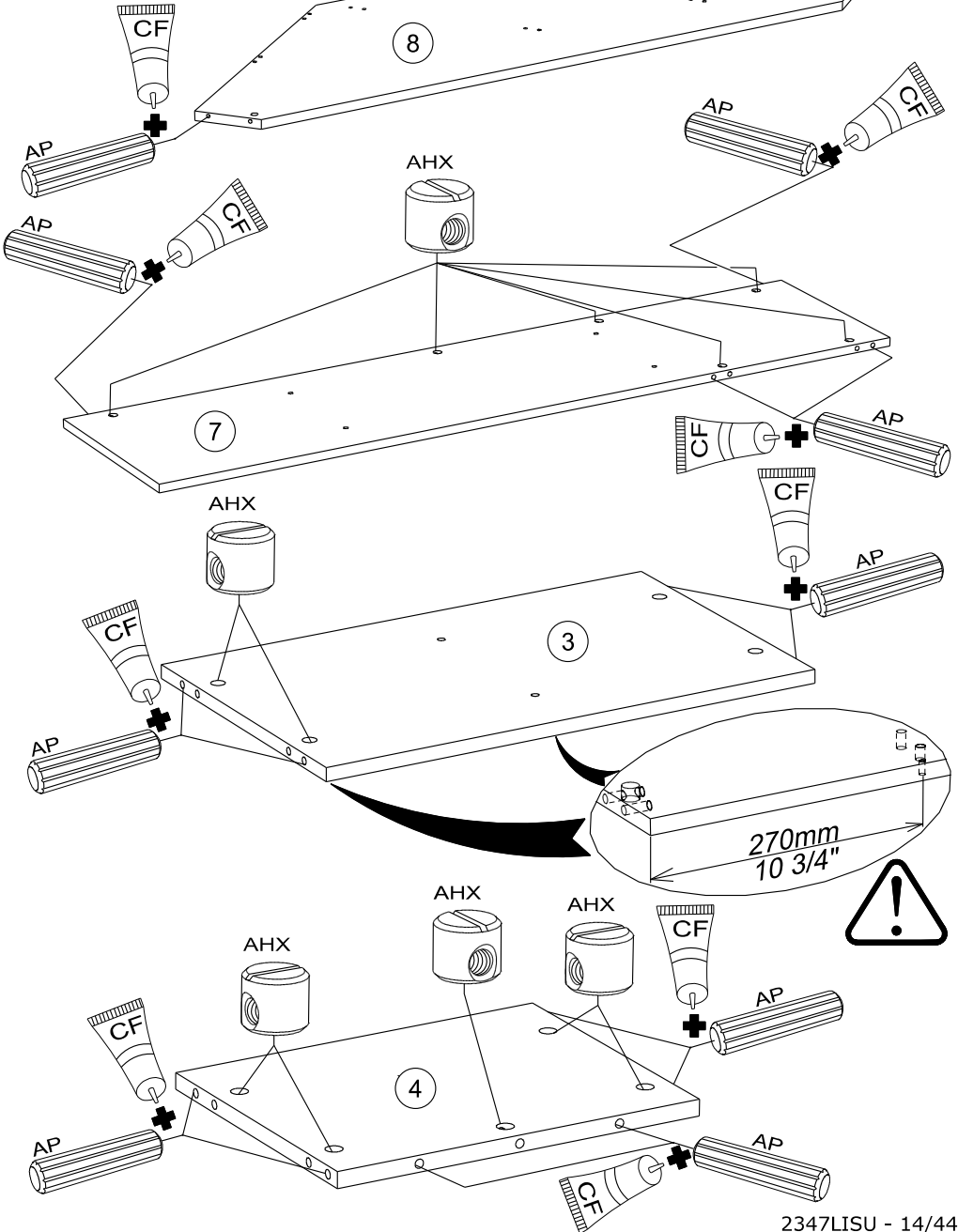

2



AP x 8



CF x 1



AHX x 8



BSD x 2

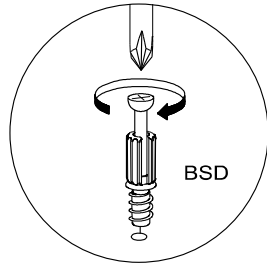
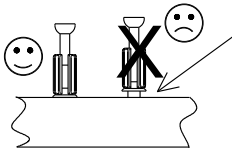

BSD

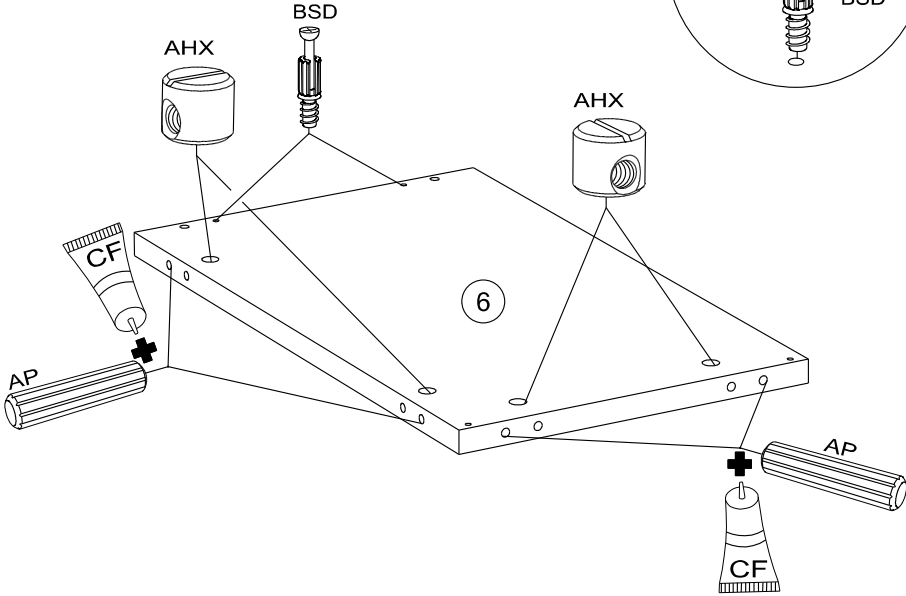

6

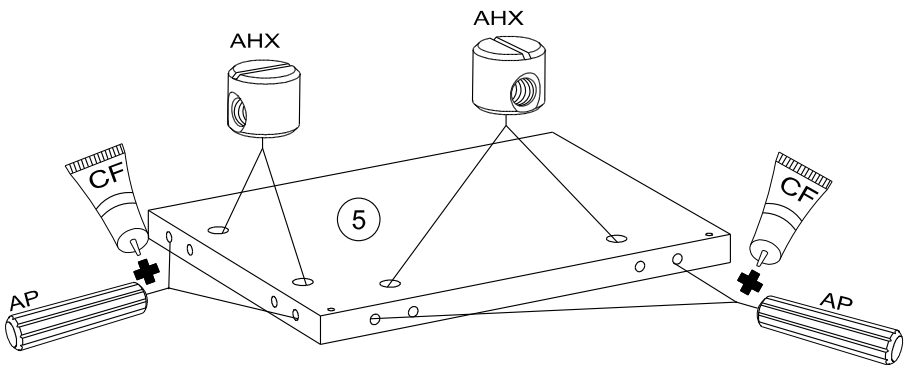

5

3



AP x 6



CF x 1



AHX x 6



ANK x 2

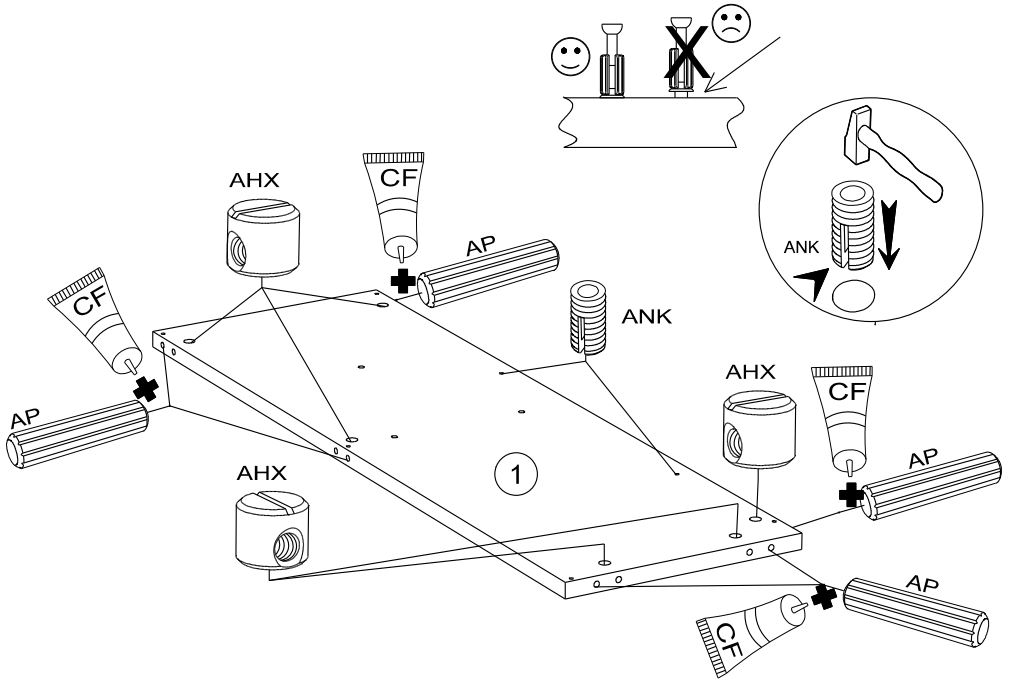

4

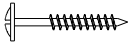

WH x 2

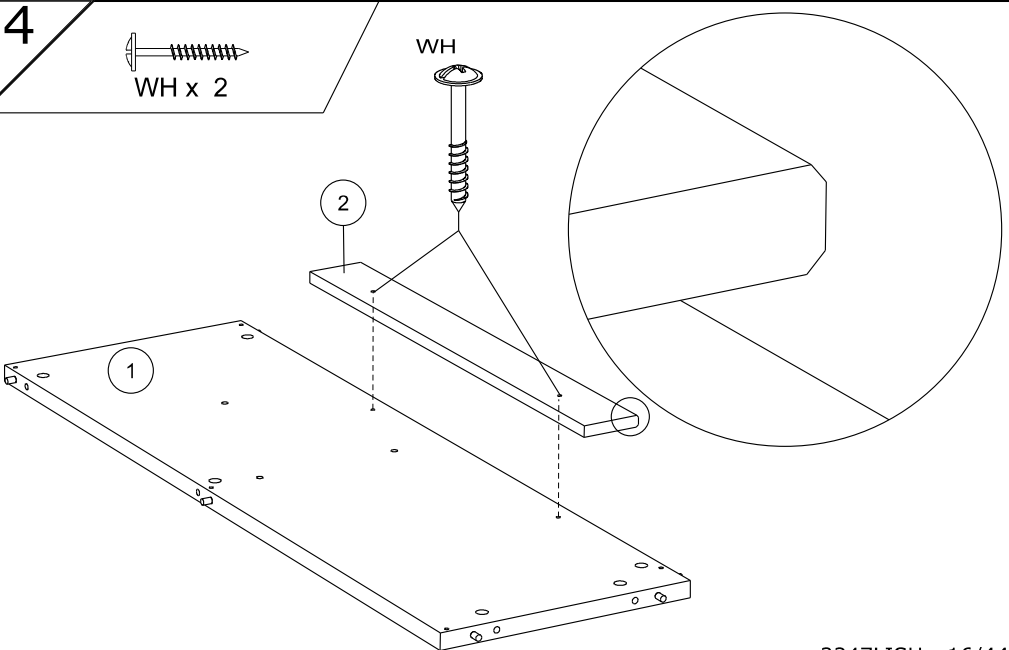



5

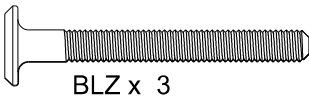

BLZ x 3



HV x 1

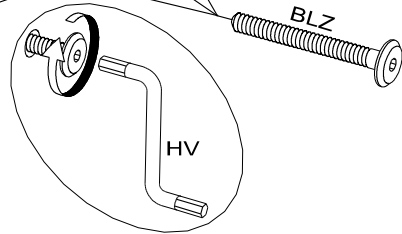
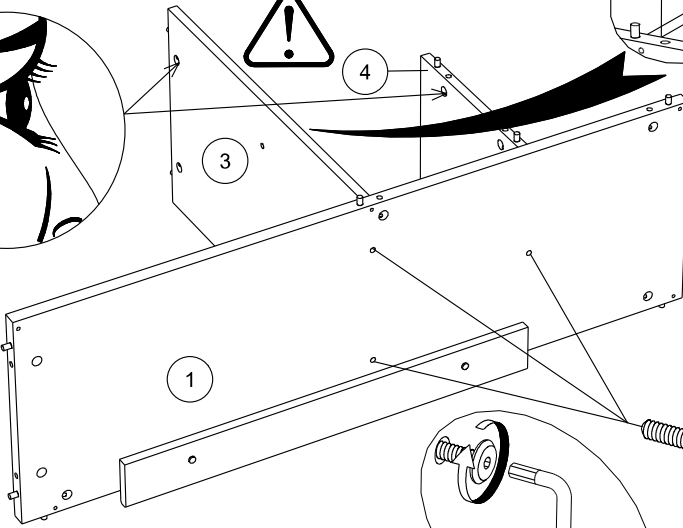
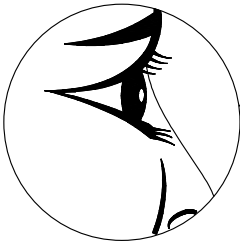
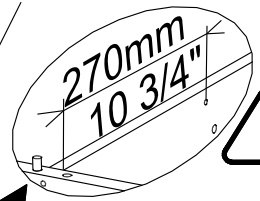

6

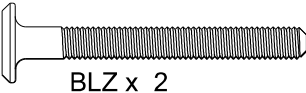

BLZ x 2



VB x 2



BAG x 2

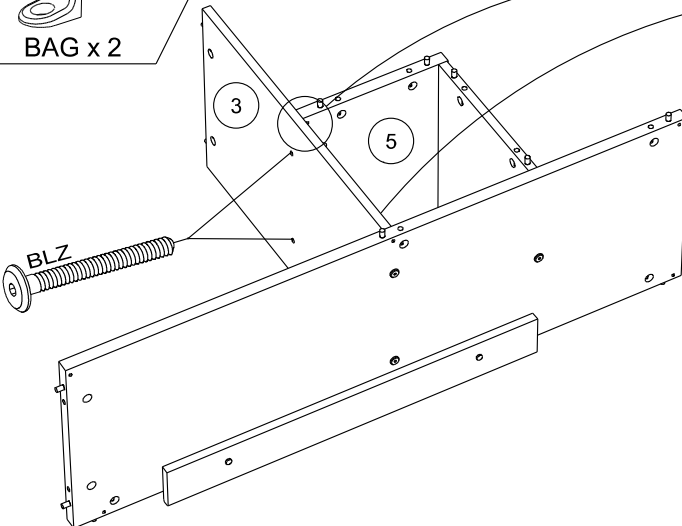
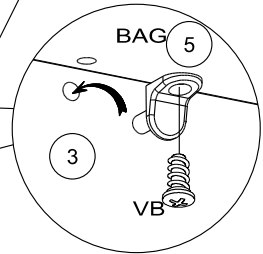

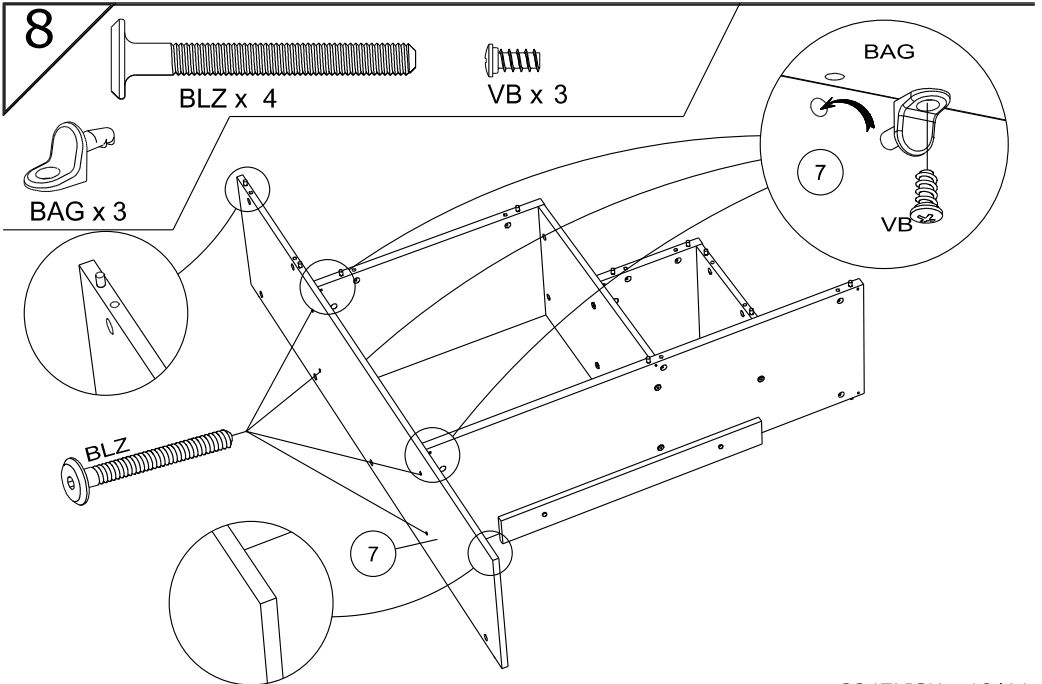
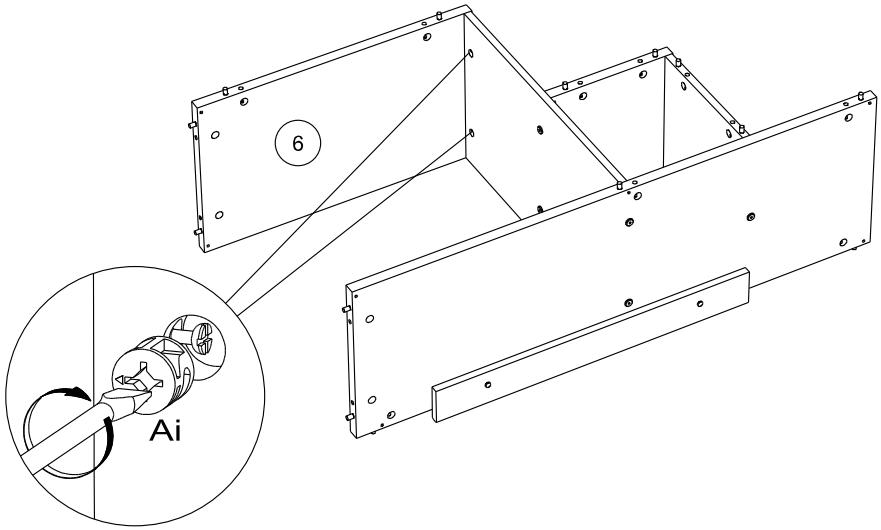
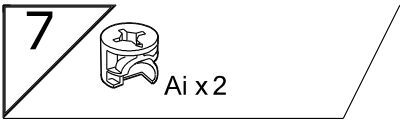

9

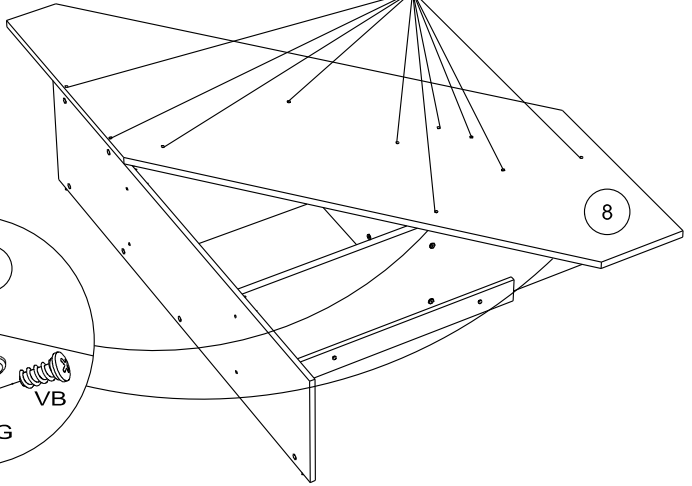
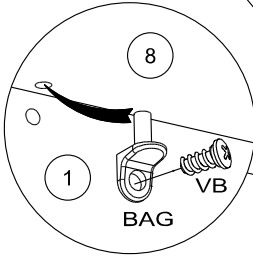
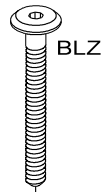
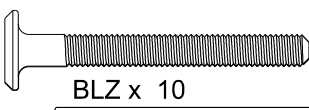

10



AHX x 3



AiO x 3



BSD x 4

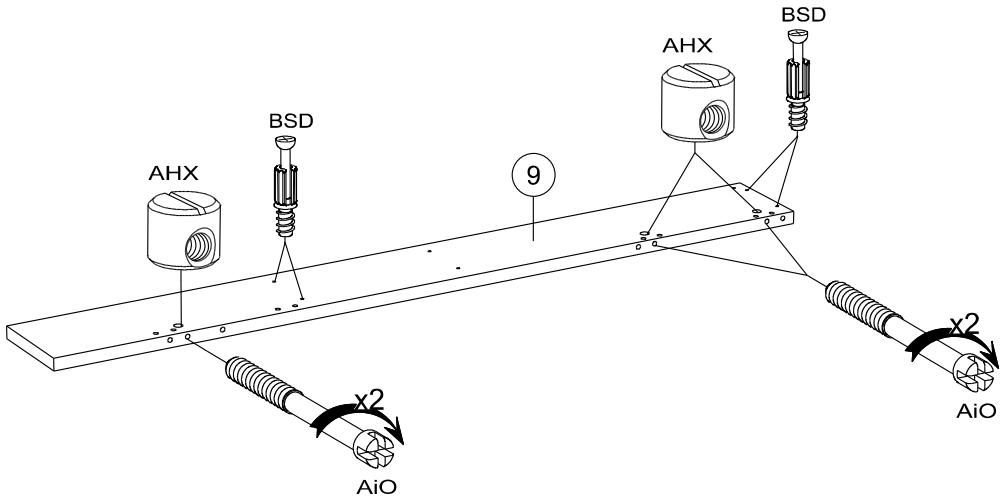

11



AHX x 3



Aio x 3



LN x 1



Vi x 2

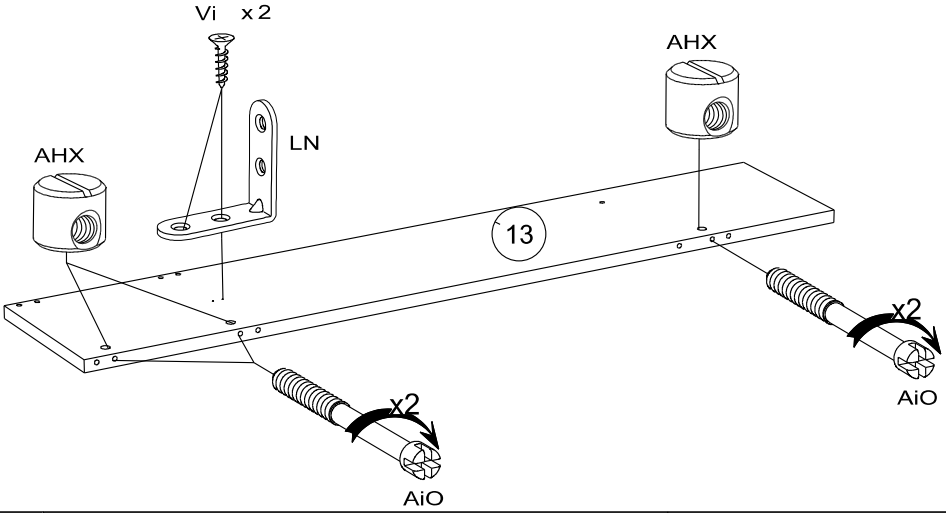

12



AP x 8



LN x 2



Vi x 4

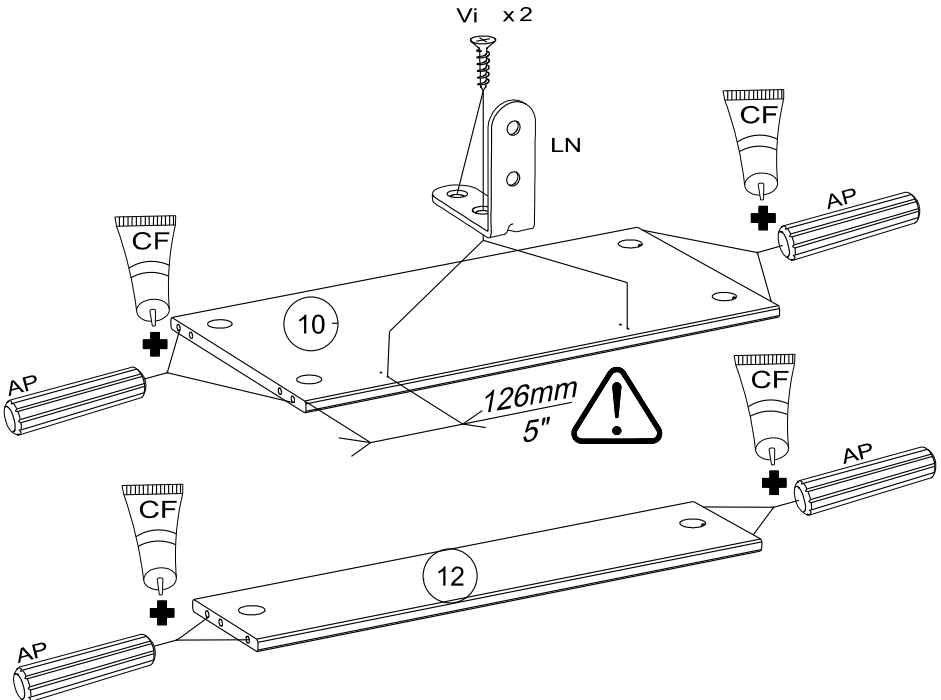

13



VW x 6

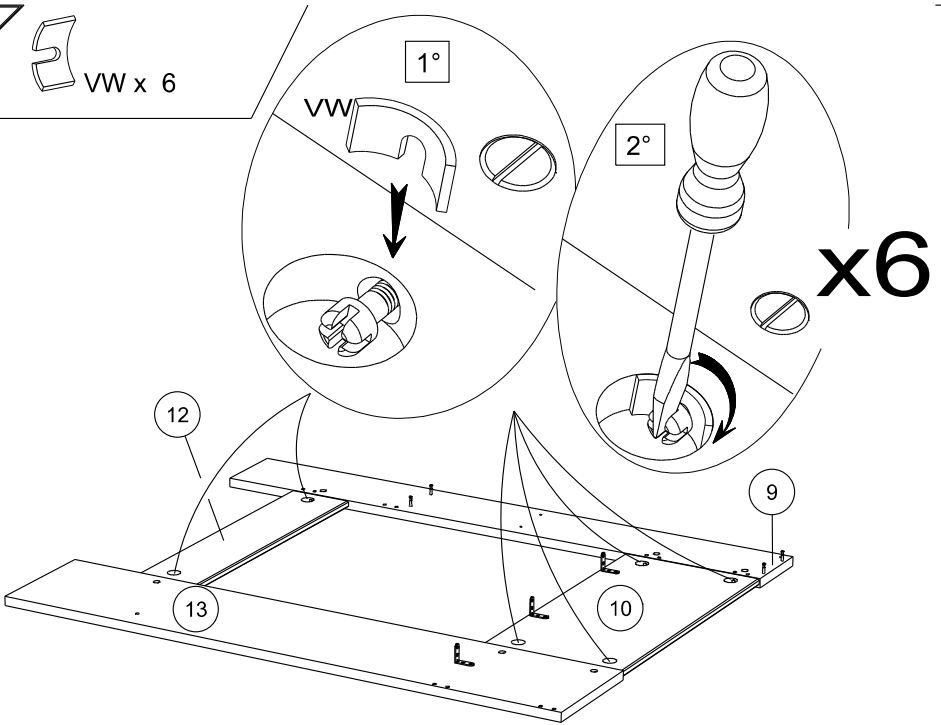

14



AP x 4



LN x 2



Vi x 4

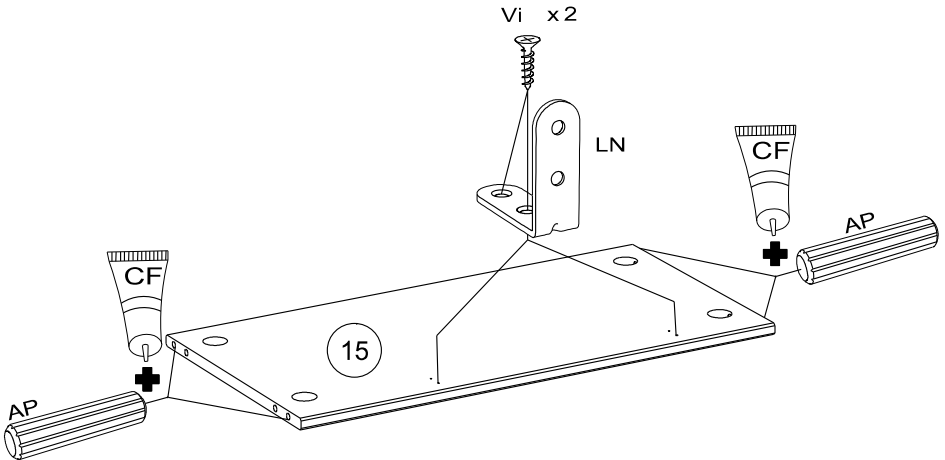

15



AHX x 4



Aio x 4

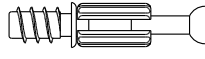

BSD x 4



LN x 1



Vi x 2

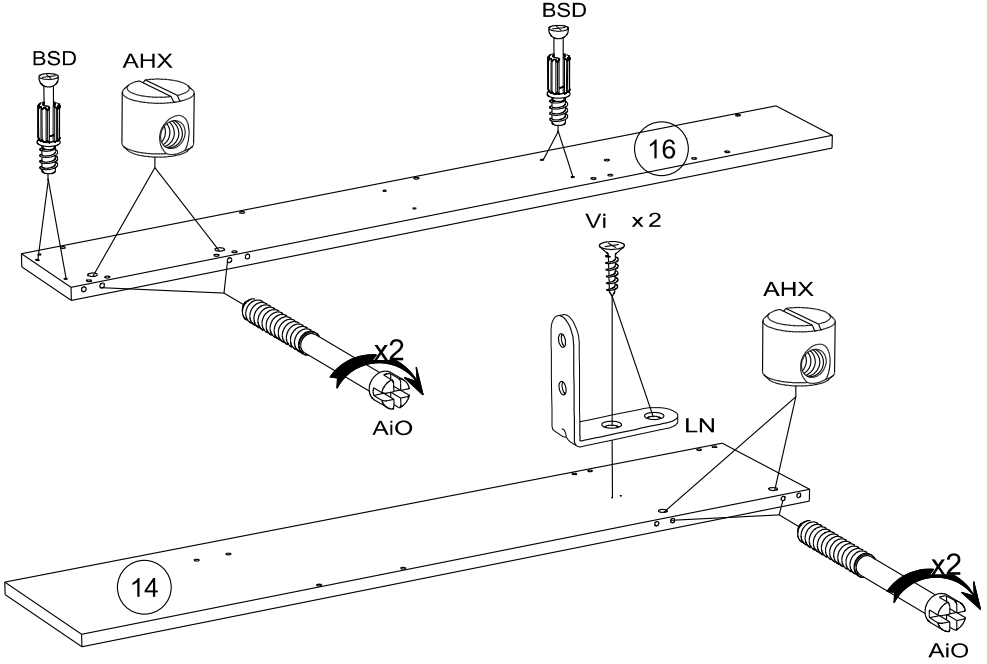

16



VW x 4

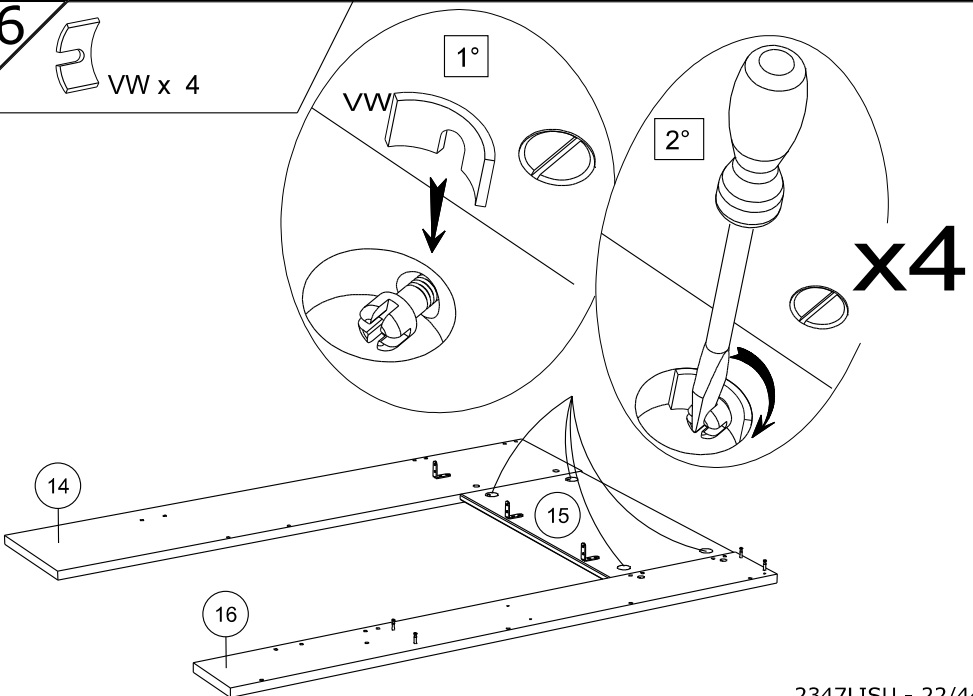

17



AP x8



LN x 5



Vi x 10



AHX x 8



ANK x 2

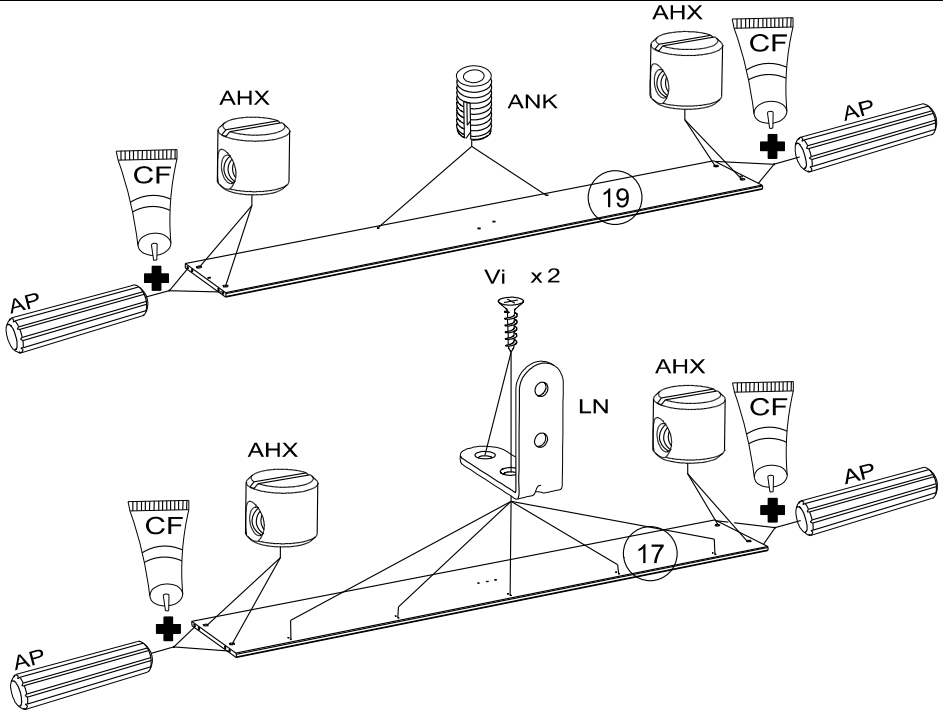

18



LN x 2



Vi x 4



ANK x 2

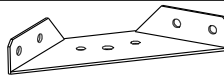

BSX x 1



VB x 2

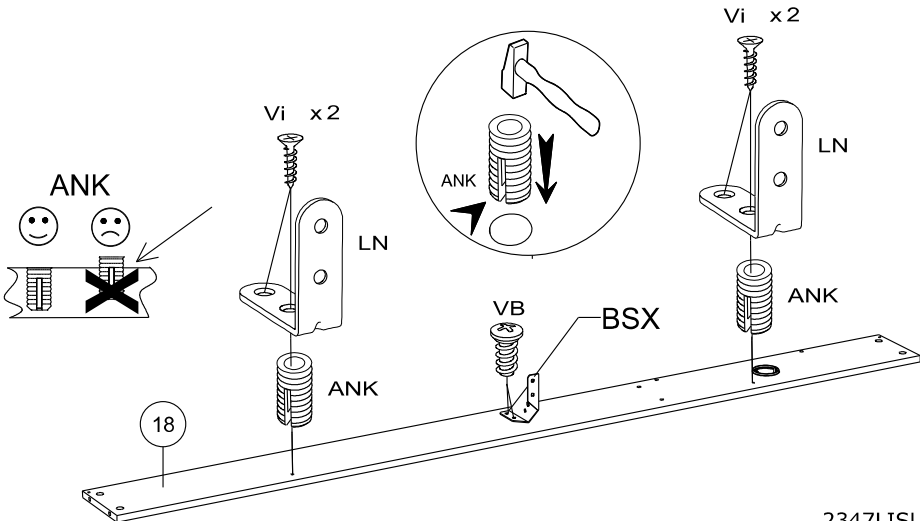

19



ANK x 2



Vi x 4



VB x 2



ANK

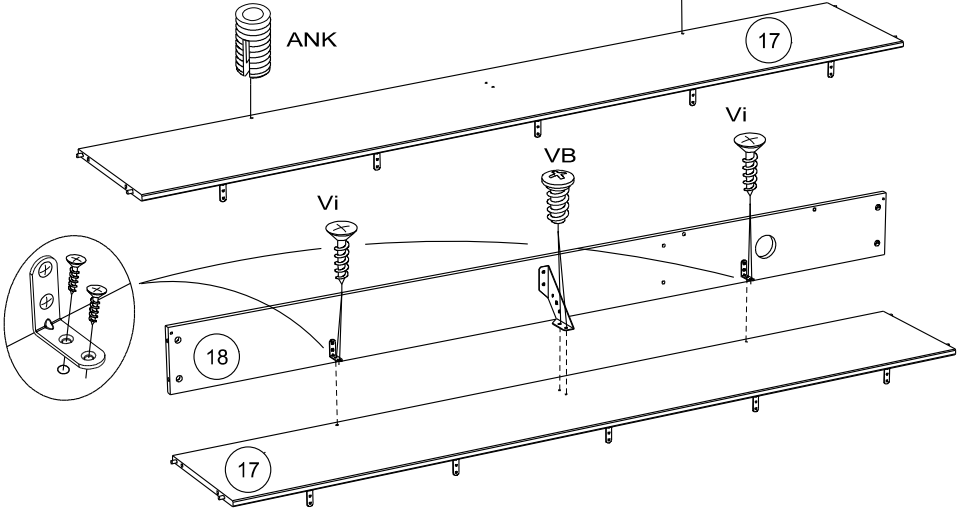

20



AP x 4



LN x 7



Vi x 14



AHX x 4



ANK x 2

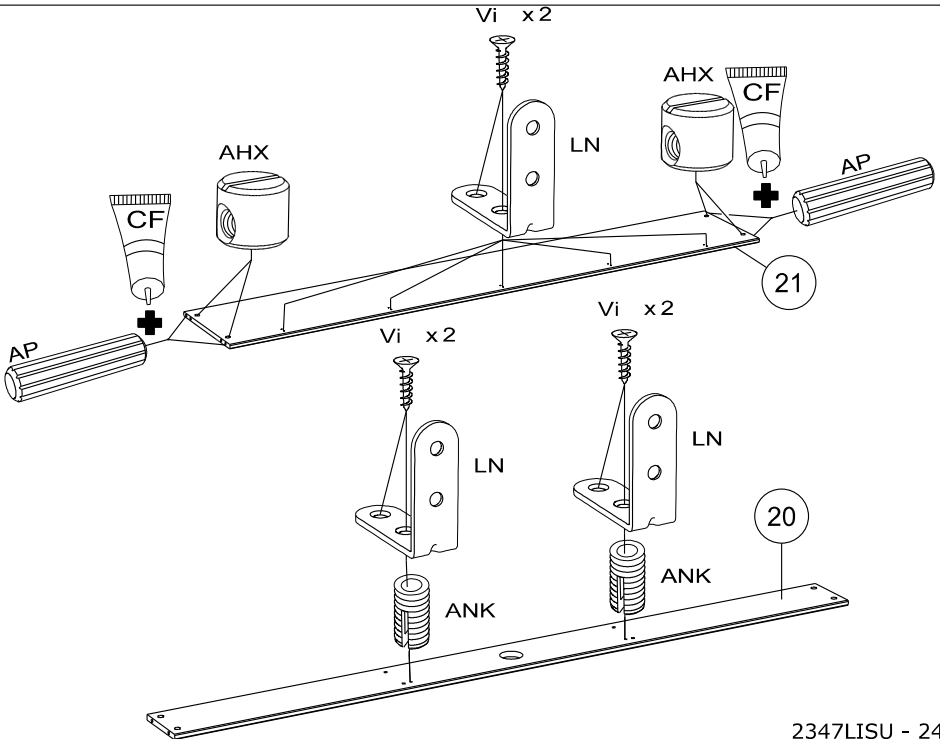



21

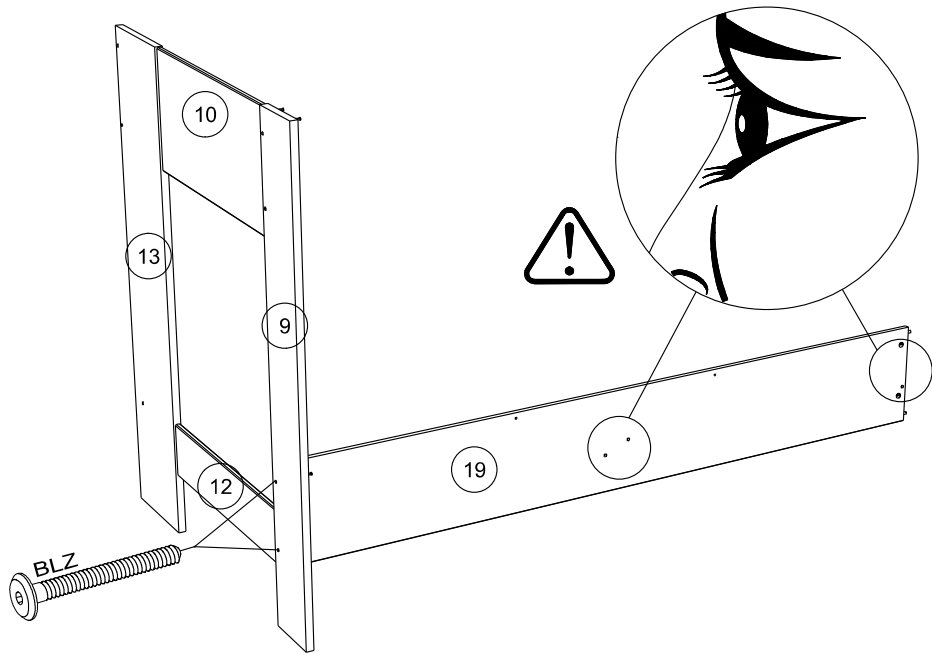
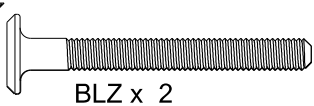

22



Ai x 2



Vi x 4

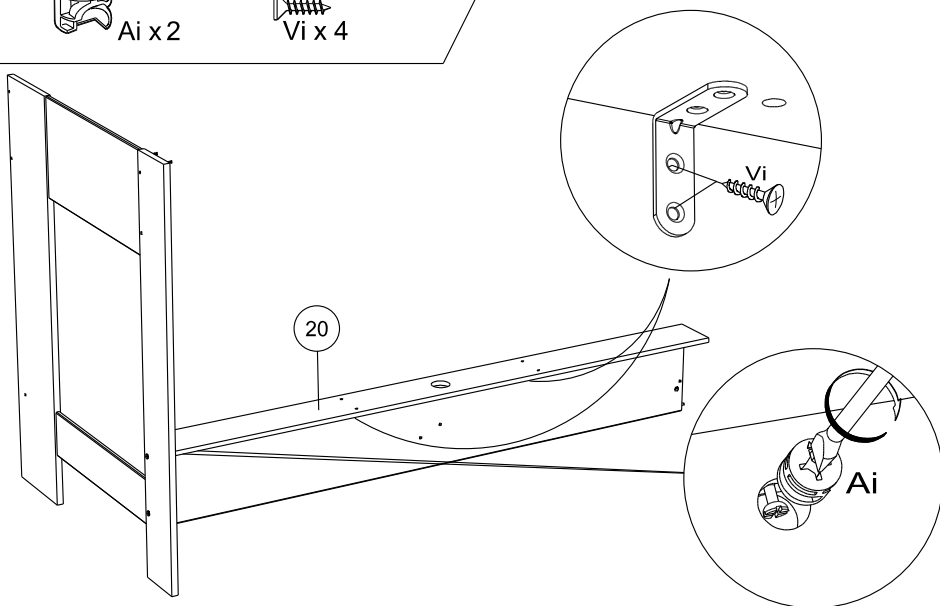

23

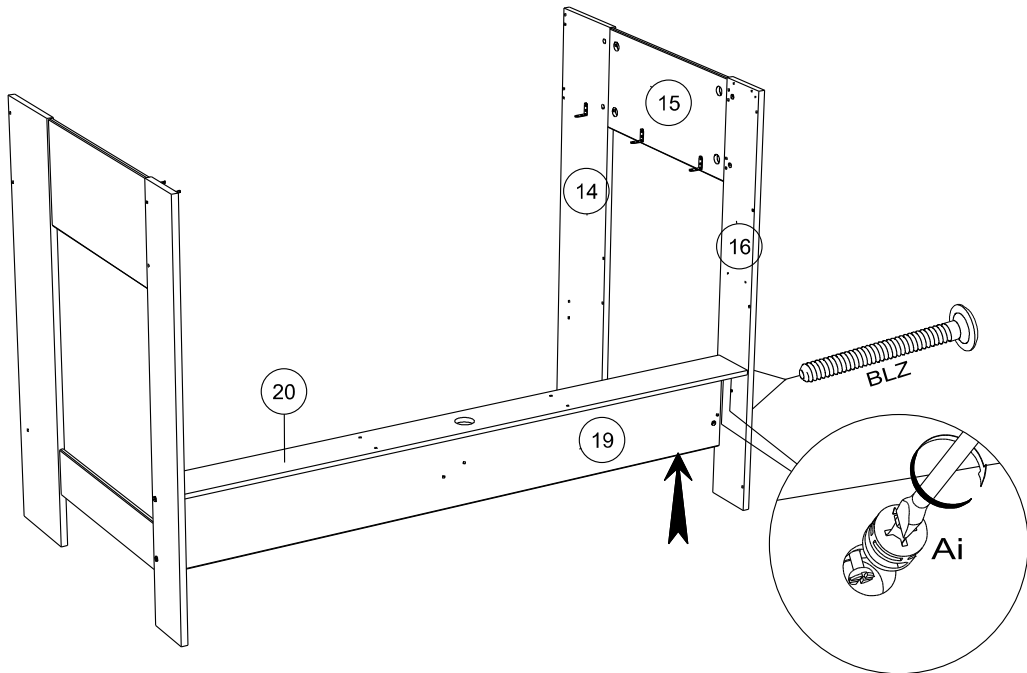
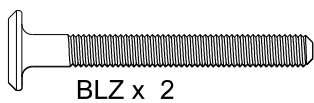

24

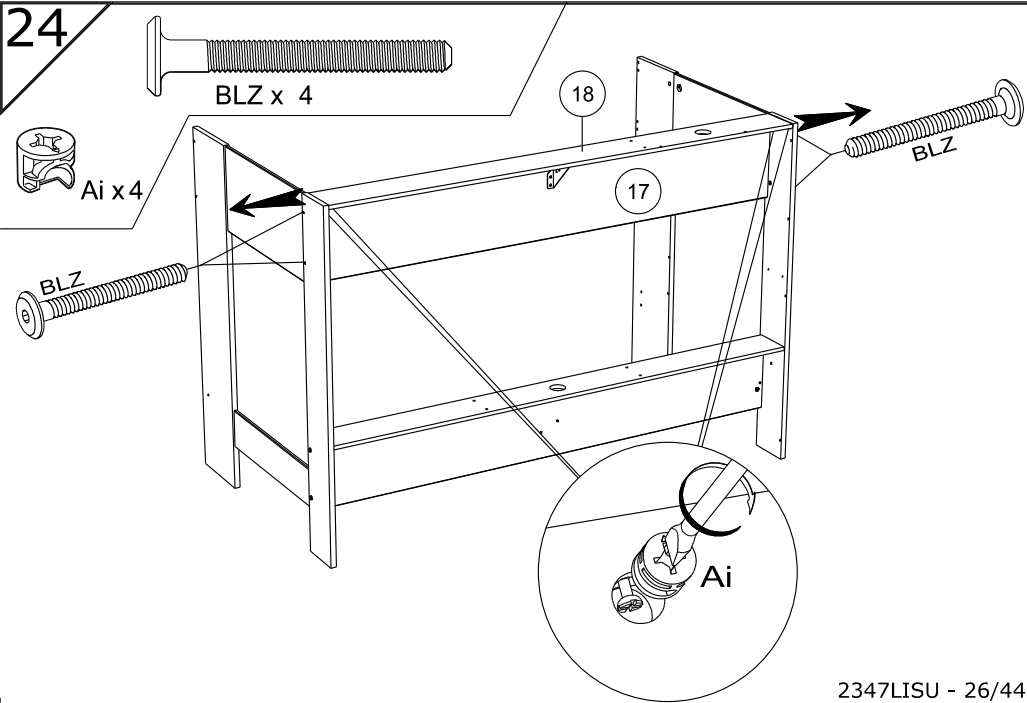
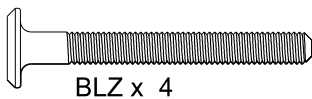

25

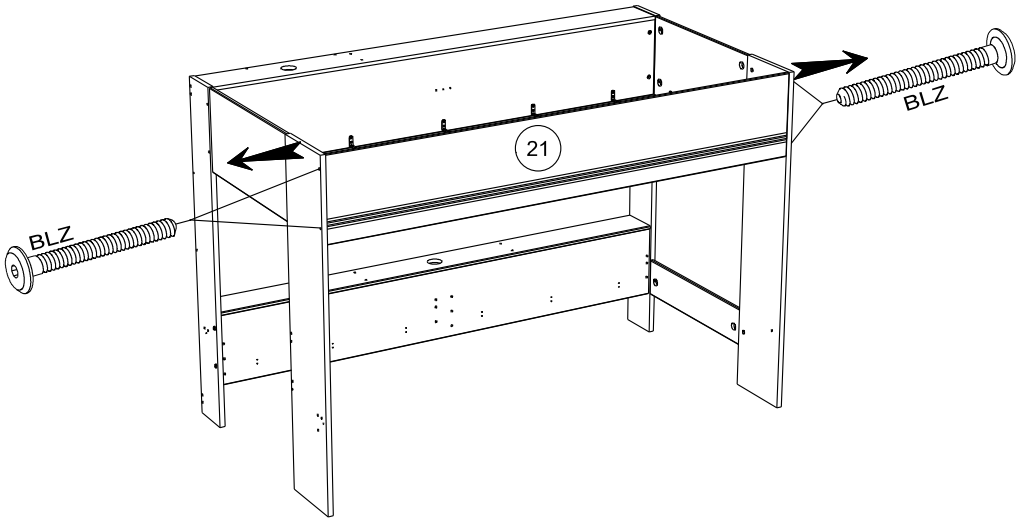
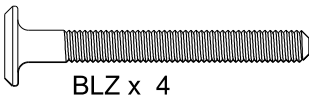

26

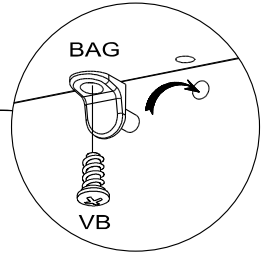
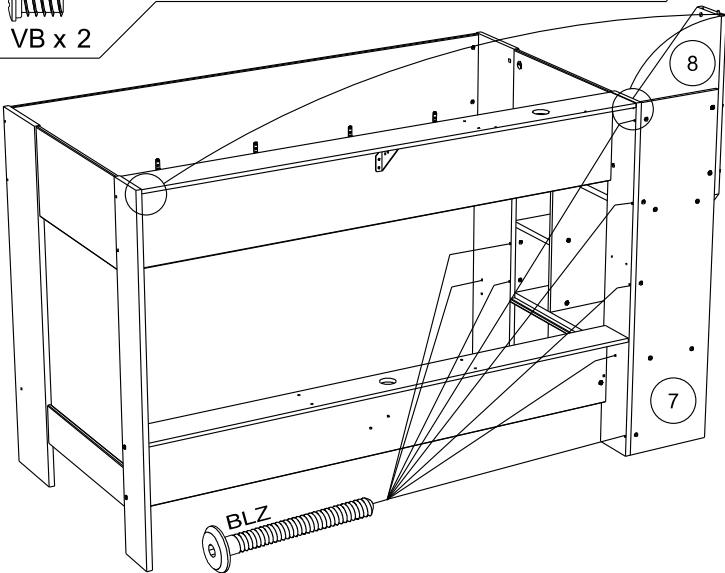
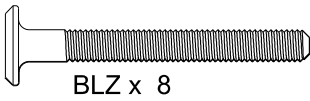

27

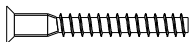

HW x 2



AP x 1

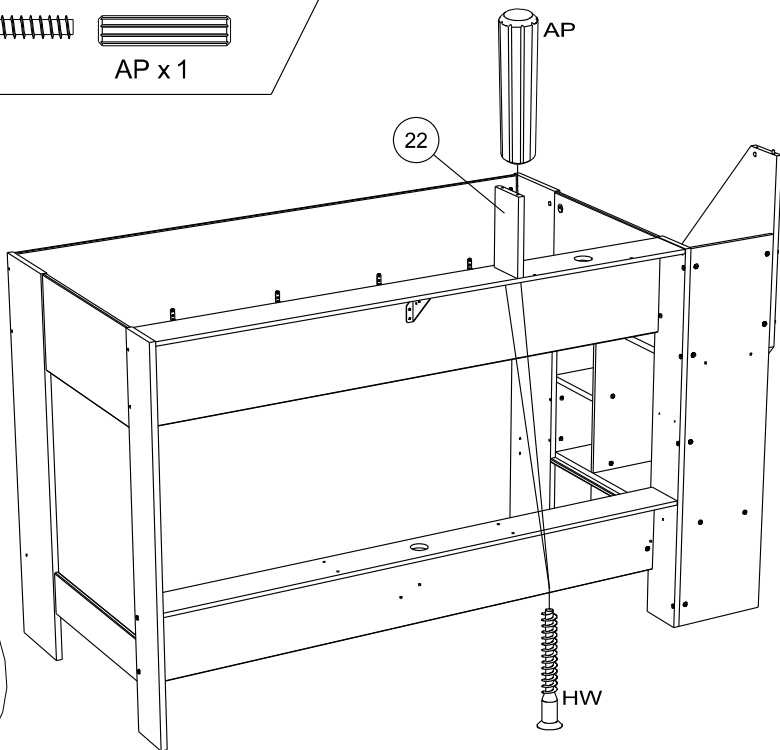
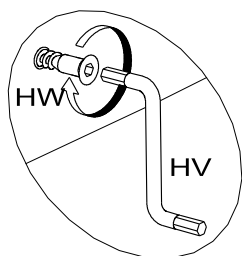

28

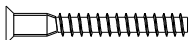

HW x 2

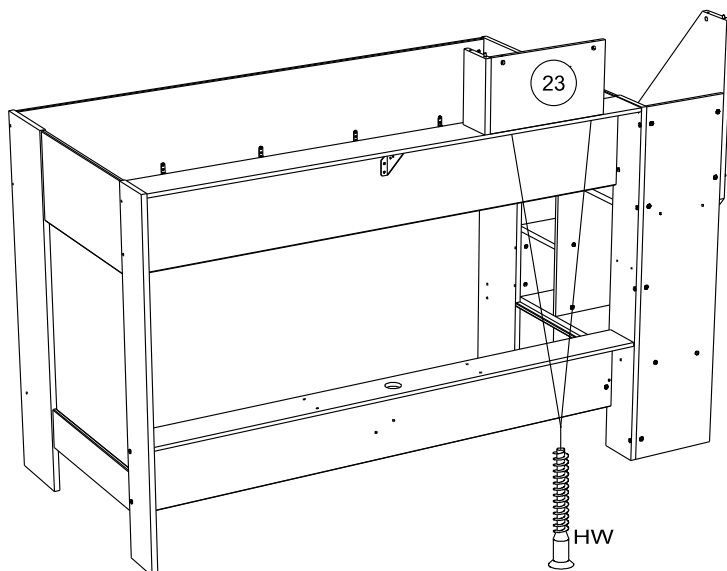

29

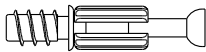

BSD x 4

BSD



24

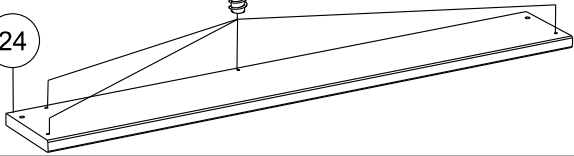

30



Ai x 4

24

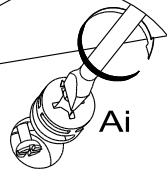
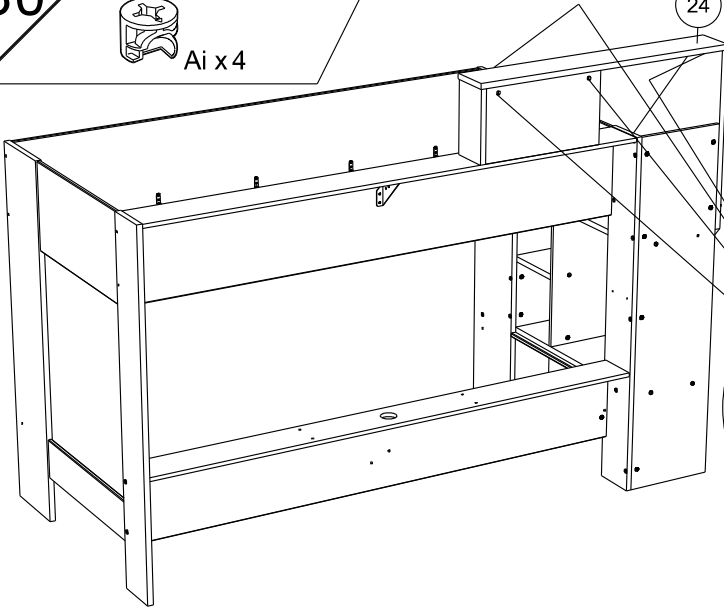

Ai

31



BAG x 2



VB x 2

BAG



VB

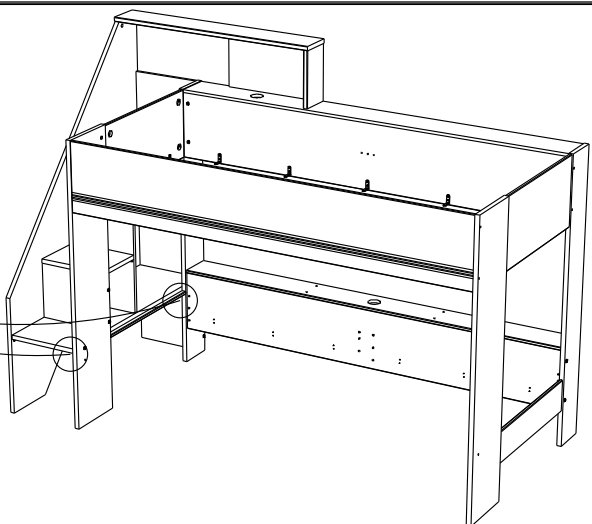

32

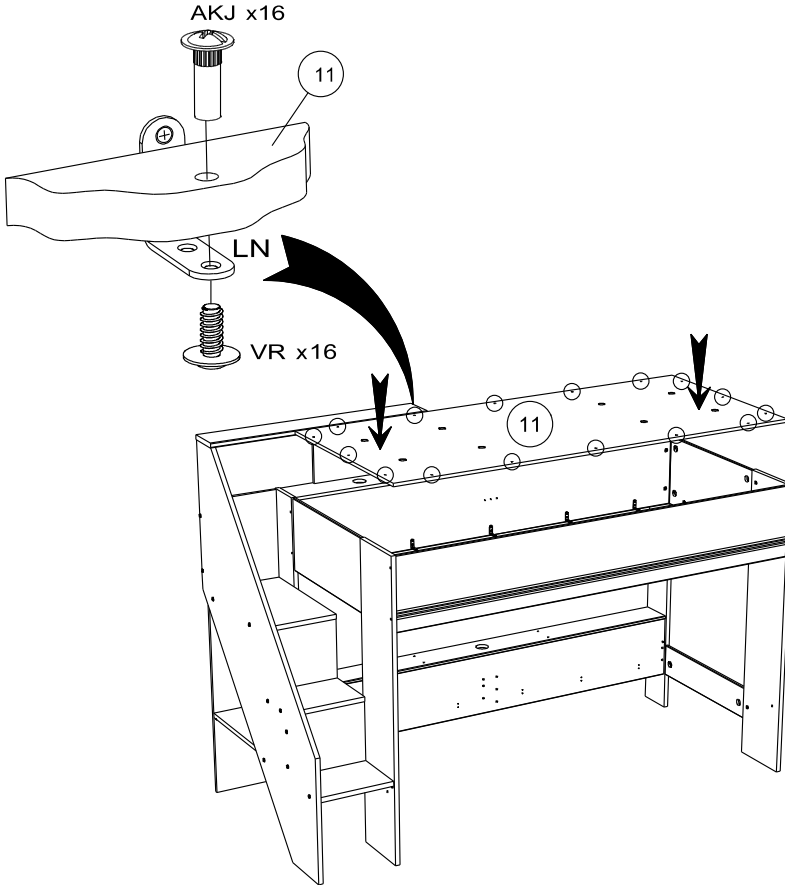
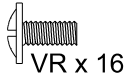

33



AP x 8



AHX x 4



LN x 10



Vi x 20

Vi x 2

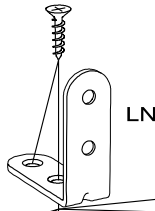

AHX



CF

+



AP

27

AHX



CF



AHX



AP

+

Vi x 2

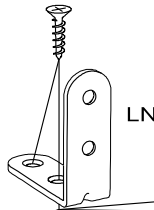

AHX



CF

+



AP

25

AHX



CF



AHX



AP

+

34



LN x 3



Vi x 6

Vi x 2

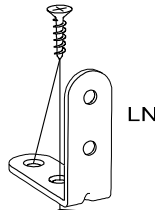

LN

26

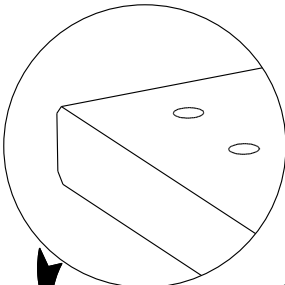

35



AKG x 2



APU x 1

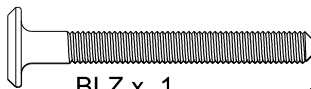

BLZ x 1

A

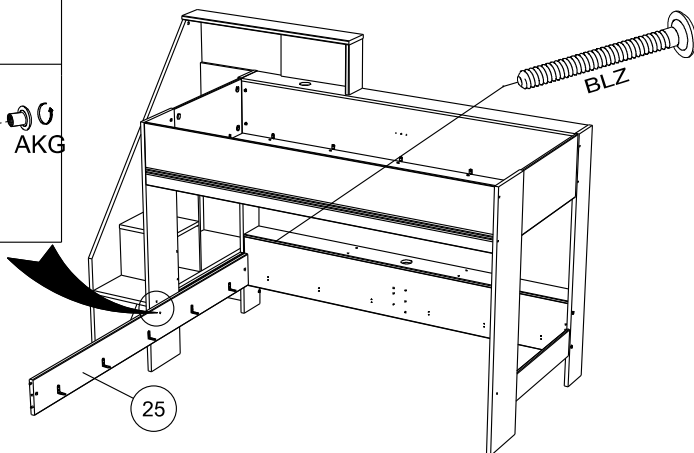
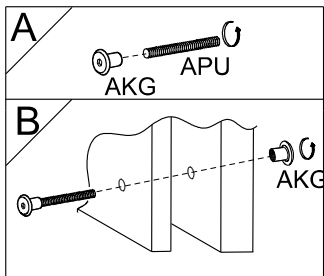
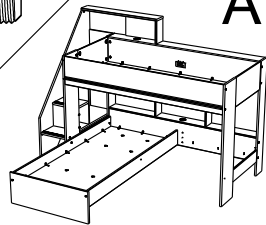

25

36

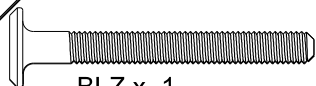

BLZ x 1

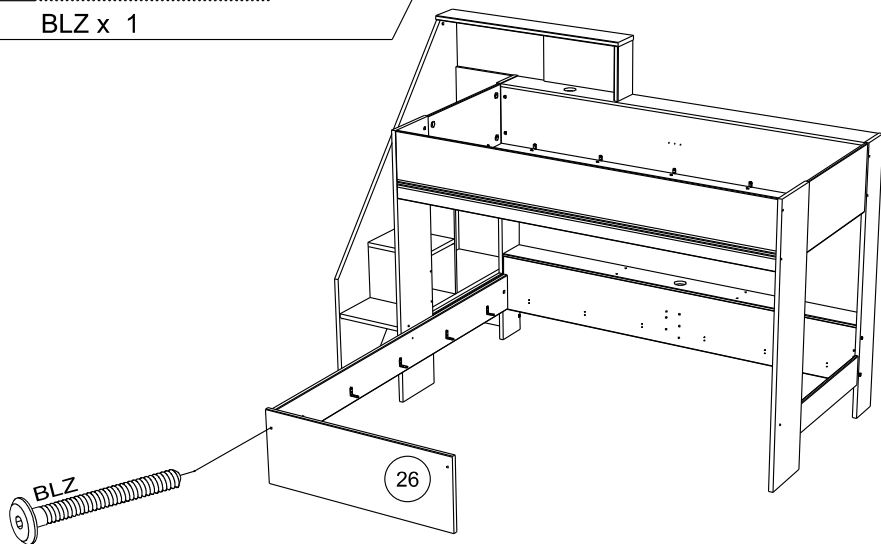

26



37

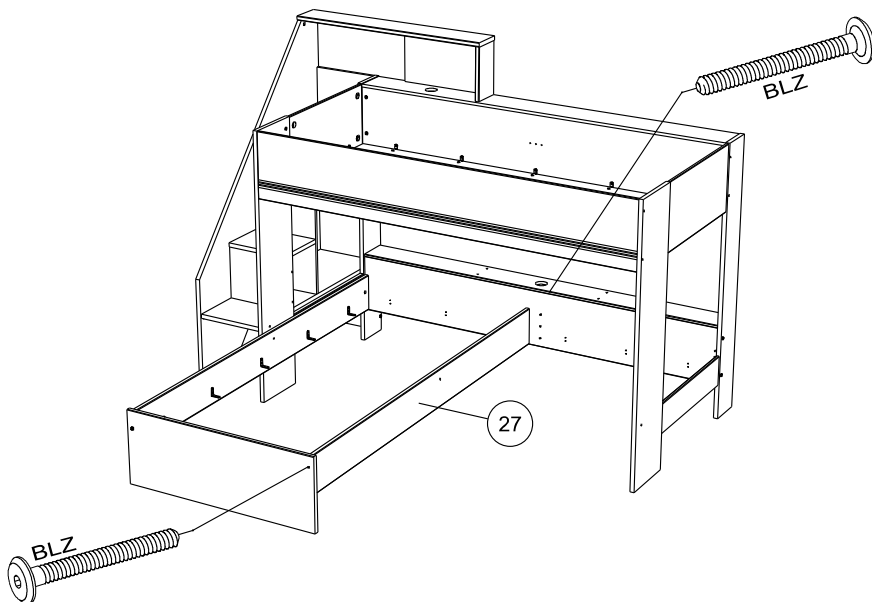
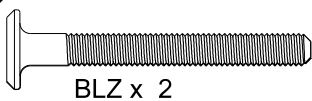

38

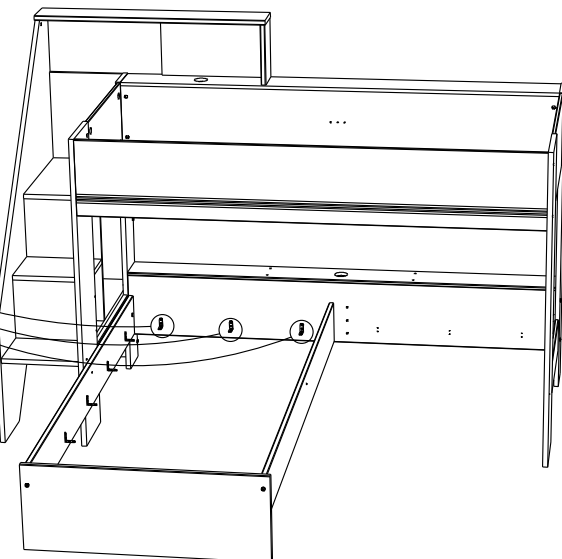
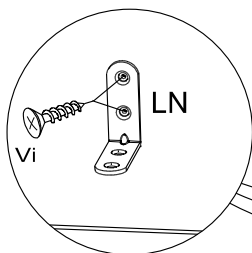
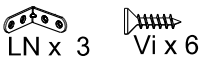

39

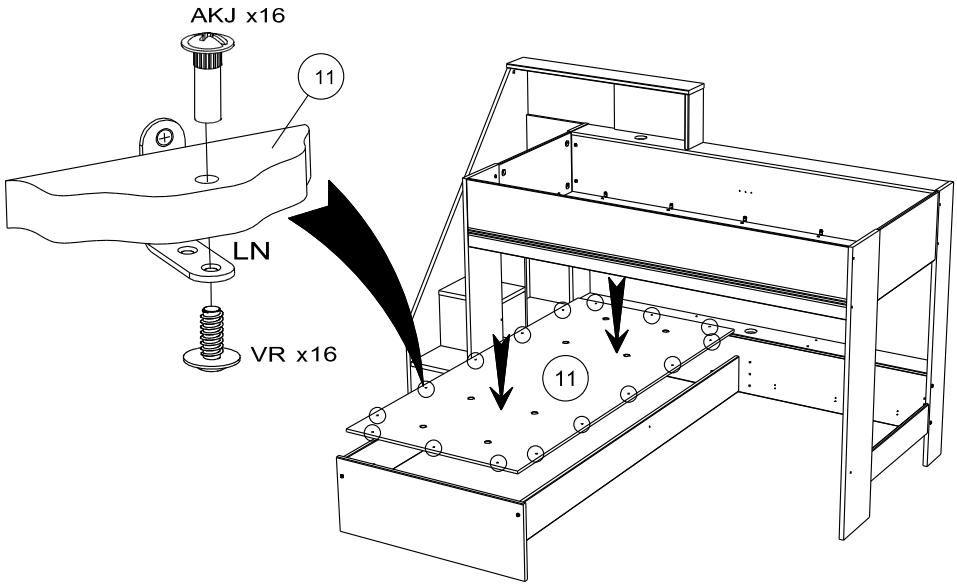
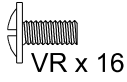
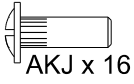

40

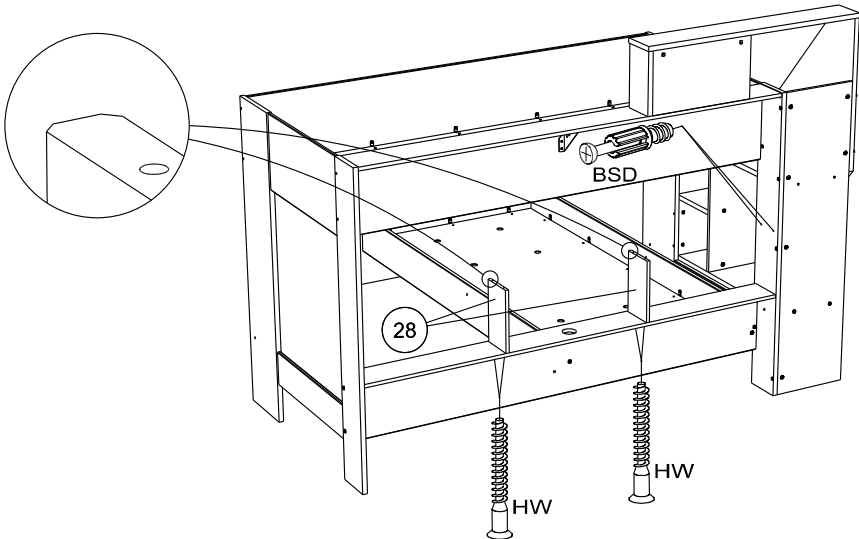
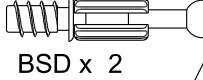
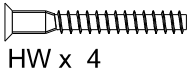

41

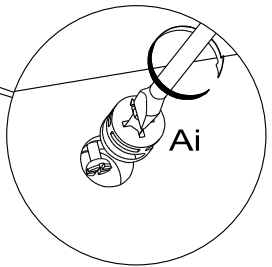
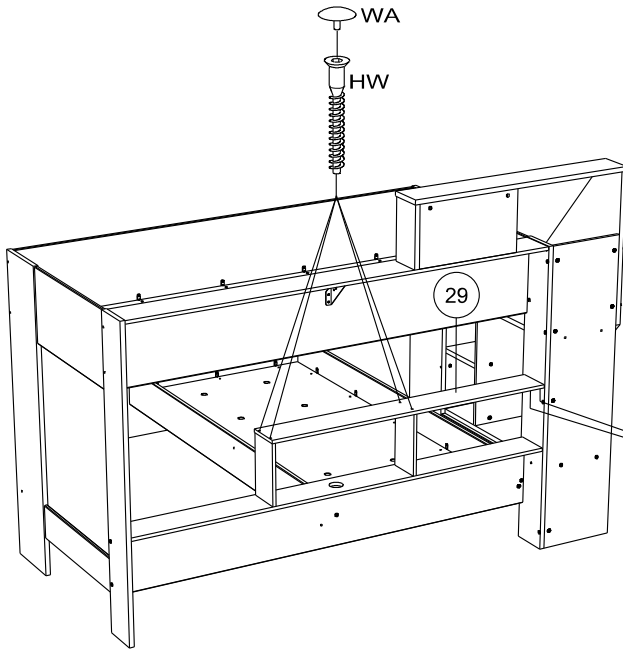
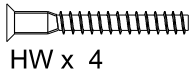

42

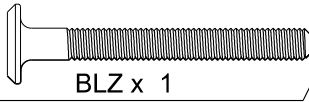

B

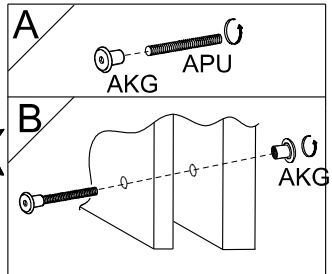
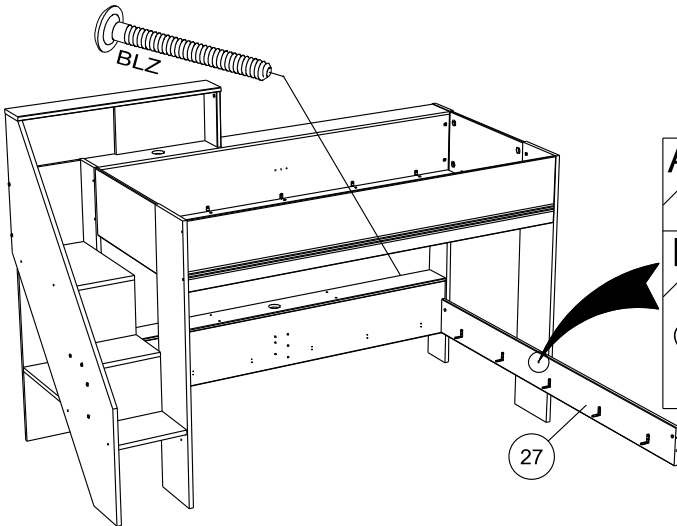
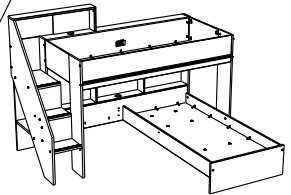

43

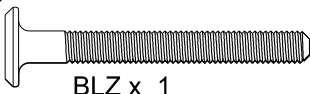

BLZ x 1

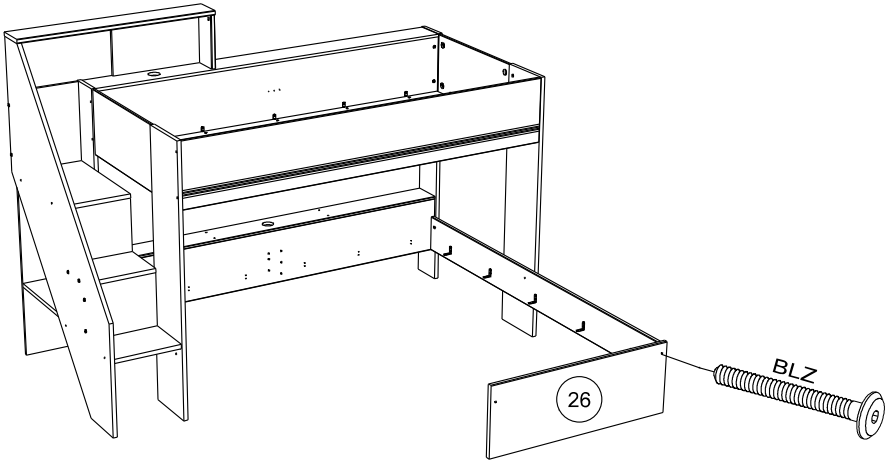

44

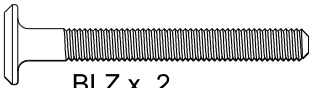

BLZ x 2

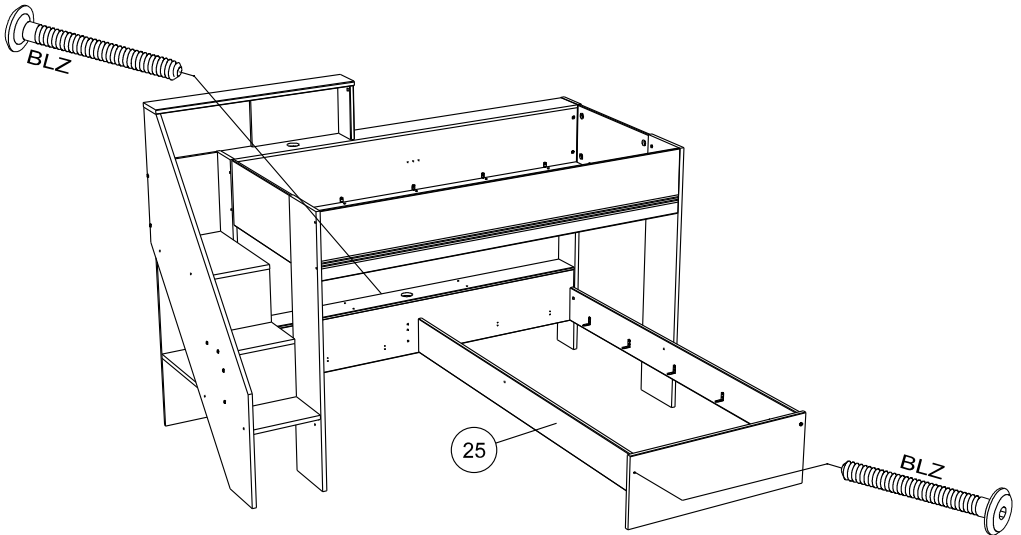

45

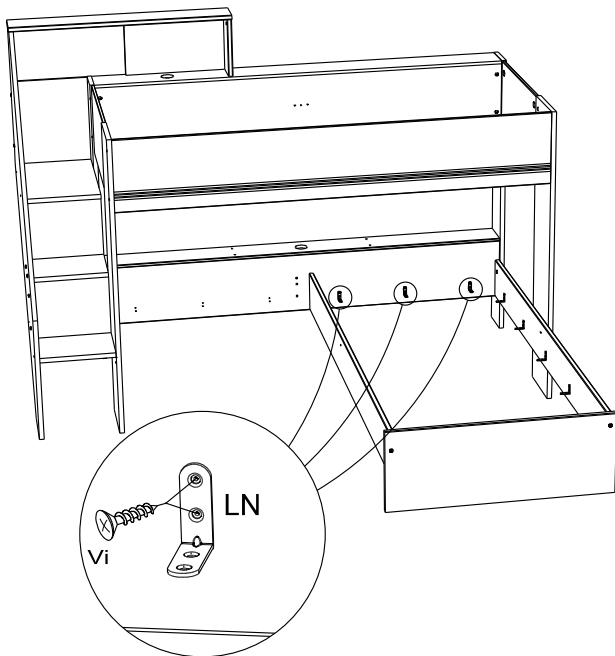

46

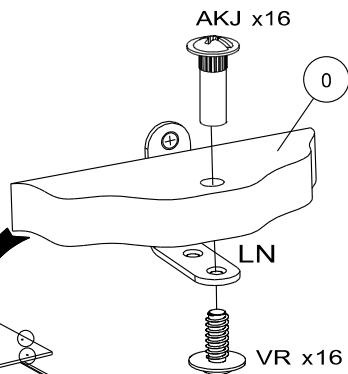
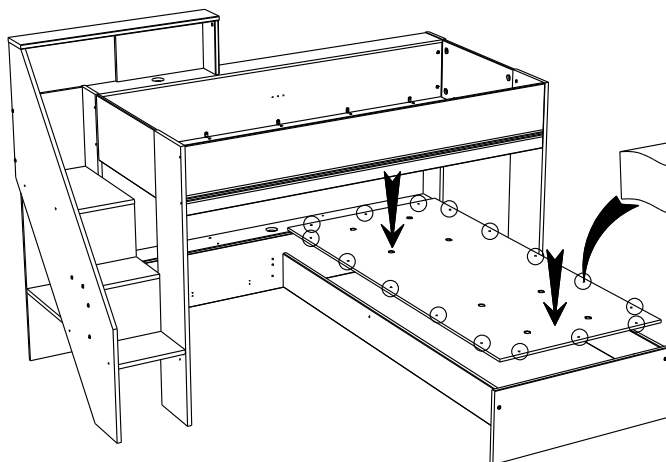
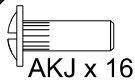

47

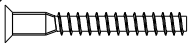

HW x 4

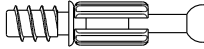

BSD x 2

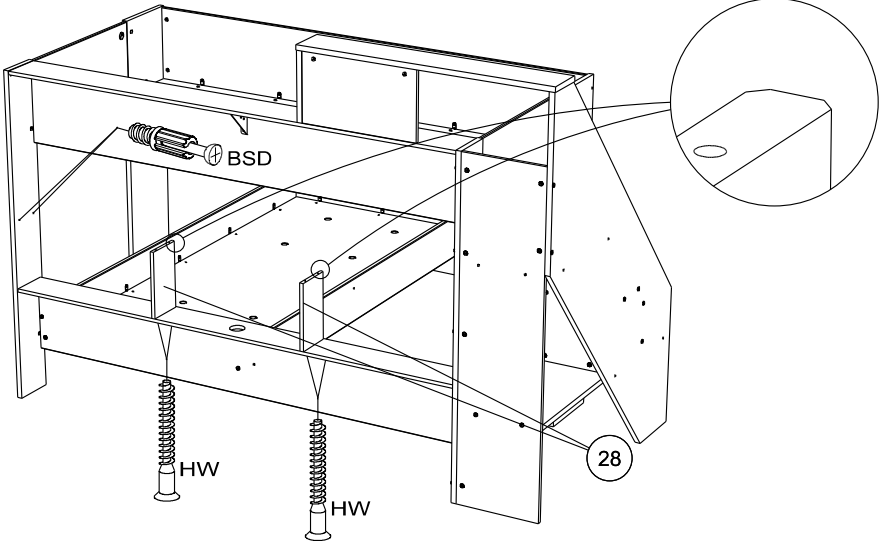

48

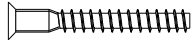

HW x 4



Ai x 2



WA x 4

WA

HW

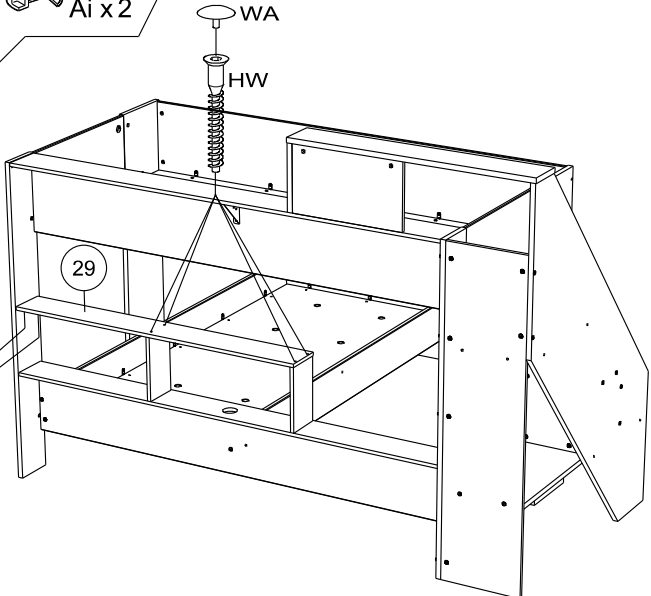

49

ZF x 10

ADP x 8

ADP x 8

CHK

CHK x 2

ZF

50

ZF x 10

ADP x 10

AHK x 3

CHK x 2

ADP x 8

CHK

20mm  
3/4"

AHK

ADP x 2

ZF

- FR** Pour votre sécurité : Fixation du meuble au mur  
Attention, la fixation doit être réalisée par une personne compétente car cela nécessite des chevilles adaptées à la nature de votre mur.
- EN** For your safety: the unit should be secured to the wall.  
NB this should be carried out by a competent person as you must use the right rawlplug for your type of wall.
- DE** Zu Ihrer Sicherheit: Befestigen Sie das Hochbett an der Wand.  
Achtung: Diese Befestigung ist durch eine fachlich kompetente Person vorzunehmen. Hierfür sind für die Bauweise Ihrer Wand geeignete Dübel einzusetzen.
- ES** Por su seguridad: Fijar el mueble a la pared.  
Advertencia: la fijación la ha de llevar a cabo por personal adecuado, ya que requiere el uso de tacos que se adapten al tipo de pared.
- PT** Para sua segurança: fixação do móvel ao muro  
Atenção: a fixação deverá ser efetuada por pessoa habilitada, visto que são necessárias cavilhas adaptadas ao tipo de parede.
- IT** Avvertenza di sicurezza: il fissaggio del mobile a parete deve essere realizzato da una persona competente, in quanto l'operazione richiede l'impiego di tasselli adatti alla natura del muro.
- NL** Voor uw veiligheid: bevestiging van het meubel aan de muur.  
Opgelet de bevestiging moet worden uitgevoerd door een bekwame persoon daar dit voor uw type muur geschikte pluggen vereist.
- CZ** Z bezpečnostních důvodů: upevněte nábytek do zdi  
Pozor, upevnění je třeba svěřit kompetentní osobě, neboť vyžaduje hmoždinky vhodné pro vaši zed'.
- HU** Az Ön biztonsága érdekében : a bútor falra rögzítése  
Figyelmeztetés : a rögzítés csak megfelelő szakképesítéssel rendelkező személy által végezhető el, mert a rögzítéshez a falnak megfelelő csavarokra van szükség.
- PL** Dla bezpieczeństwa: mocowanie mebla do ściany  
Uwaga, mocowanie musi zostać wykonane przez osobę kompetentną, ponieważ wymaga to zastosowania kołków dostosowanych do rodzaju ściany.
- RO** Pentru securitatea dumneavoastră: fixarea mobilierului de perete  
Atenție, fixarea trebuie să fie realizată de o persoană calificată, deoarece sunt necesare dispozitive de fixare adaptate caracteristicilor peretelui dumneavoastră
- RU** Для вашей безопасности: Крепление мебели к стене  
Внимание! Крепление должно производиться опытным специалистом, т.к. для такой установки потребуются штифты, соответствующие типу вашей стены.
- SK** Z bezpečnostných dôvodov: nábytok upevnite k stene.  
Dbajte na to, aby upevnenie vykonala kompetentná osoba, pretože pri upevňovaní sa vyžadujú kolíky vhodné do materiálu, z ktorého je stena vyrobená.
- TR** Güvenliğiniz için: Mobilyanın duvara sabitlenmesi  
Dikkat, sabitleme işlemi uzman biri tarafından yapılmalıdır çünkü bu işlem için duvarınızın malzemesine uygun dübellerin kullanılması gerekmektedir
- GR** Για την ασφάλειά σας : στερέωση των επίπλων στον τοίχο.  
Προσοχή, η στερέωση πρέπει να γίνεται από ικανό άτομο, καθώς απαιτούνται σφήνες προσαρμοσμένες στη φύση του τοίχου σας.

#### اللغة العربية

لسلامتک الشخصية: تثبيت قطعة الأثاث على الحائط  
تحذير، يجب أن يقوم شخص متخصص بعملية التثبيت على الحائط إذ أنها تتطلب اسفيناً  
معيناً يتوافق مع طبيعة الحائط نفسه.



52

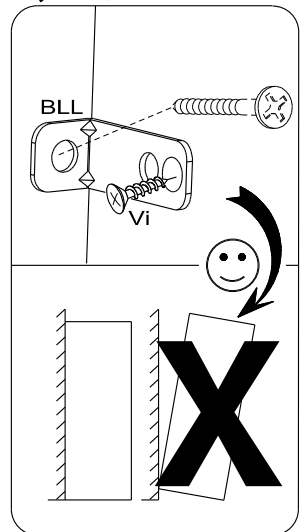
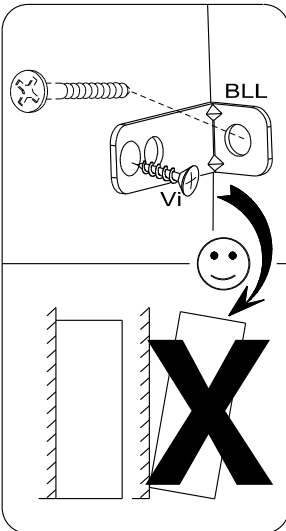
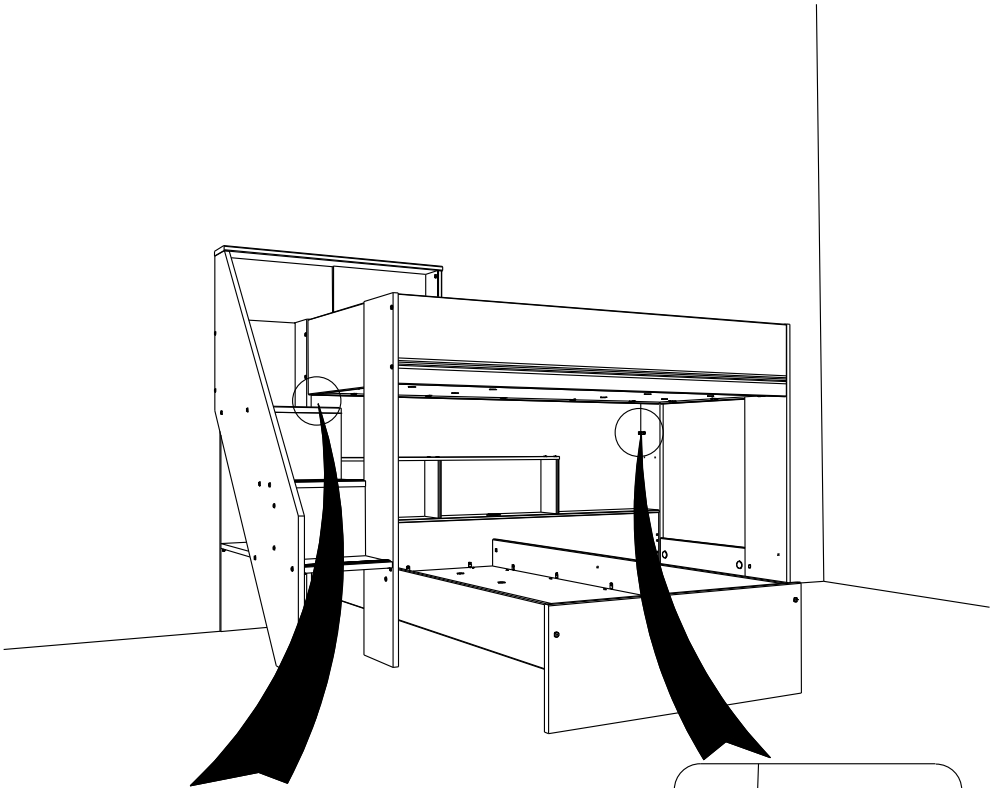
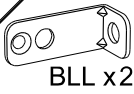

**FR** LA FACE SUPERIEURE DU MATELAS NE DOIT PAS SE TROUVER  
AU DESSUS DE LA MARQUE FAITE SUR LE LIT

**EN** THE TOP SIDE OF THE MATTRESS SHOULD NOT BE HIGHER THAN THE LEVEL INDICATED ON THE BED.

**DE** DIE OBERSEITE DER MATRATZE DARF NICHT ÜBER DIE AM BETT VORHANDENE MARKIERUNG ÜBERSTEHEN

**ES** LA PARTE SUPERIOR DEL COLCHÓN NUNCA HA DE ENCONTARSE ENCIMA DE LA MARCA HECHA SOBRE LA CAMA

**PT** A FACE SUPERIOR DO COLCHÃO NÃO DEVE FICAR EM CIMA DA MARCA FEITA NA CAMA

**IT** IL LATO SUPERIORE DEL MATERASSO NON DEVE TROVARSI AL DI SOPRA DEL MARCHIO POSTO SUL LETTO

**NL** DE BOVENZIJDE VAN DE MATRAS MAG NIET BOVEN DE MARKERING OP HET BED UITSTEKEN

**CZ** HORNÍ STRANA MATRACE NESMÍ VYČNÍVAT NAD ZNAČKU NA POSTELI

**HU** A MATRAC FELSŐ OLDALA NEM LEHET MAGASABBAN MINT AZ ÁGYON TALÁLHATÓ JELZÉS

**PL** GÓRNA POWIERZCHNIA MATERACA NIE MOŻE ZNAJDOWAĆ SIĘ POWYŻEJ OZNACZENIA NA ŁÓŻKU

**RO** FAȚA SUPERIOARĂ A SALTELEI NU TREBUIE SĂ DEPĂȘEASCĂ MARCAJUL DE PE PAT

**RU** НАРУЖНАЯ ЧАСТЬ МАТРАСА НЕ ДОЛЖНА НАХОДИТЬСЯ ВЫШЕ СПЕЦИАЛЬНОЙ ОТМЕТКИ НА КРОВАТИ

**SK** VRCHNÁ ČASŤ MATRACA SA NESMIE NACHÁDZAŤ NAD ZNAČNOU VYZNAČENOU NA POSTELI

**TR** SOMYANIN ÜST YÜZÜ, YATAK ÜZERİNDEKİ İŞARETİN ÜSTÜNDE YER ALMAMALIDIR

الجانب العلوي للمرتبة لا يجب أن يتجاوز العلامة الموجودة على السرير

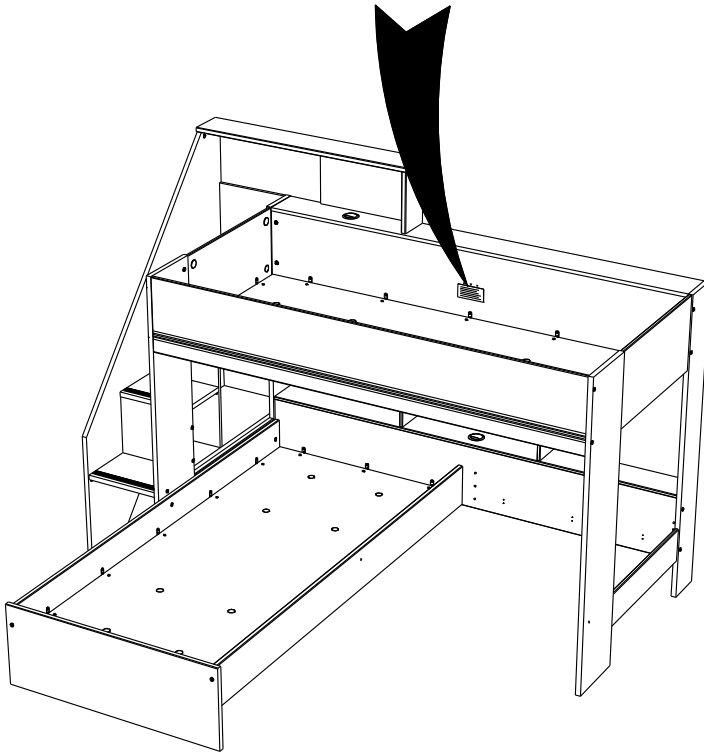

- FR** Attention pour votre sécurité, ne pas dépasser les charges maxi
- EN** Caution! For your safety, do not exceed the maximum load
- DE** Achtung: Zu Ihrer Sicherheit ist die zulässige Höchstlast nicht zu überschreiten
- ES** Advertencia: Por su seguridad, no superar las cargas maxi
- PT** Atenção, para sua segurança, não ultrapasse as cargas máximas
- IT** Attenzione, per ragioni di sicurezza, non superare i valori massimi di carico indicati
- NL** Opgelet, voor uw veiligheid het maximum gewicht niet overschrijden
- CZ** Pozor, z bezpečnostních důvodů nepřekračujte maximální zátěž
- HU** Az Ön biztonságá érdekében ne haladja meg a maximális terhelést
- PL** Uwaga! Ze względów bezpieczeństwa nie przekraczać obciążeń maksymalnych
- RO** Atenție, pentru securitatea dumneavoastră, nu depășiți sarcina maximă
- RU** Внимание! Для вашей безопасности, не превышайте максимально допустимый вес
- SK** Upozornenie: Z bezpečnostných dôvodov neprekračujte maximálne záťaž
- TR** Dikkat, güvenliğiniz için maksimum yük seviyelerini aşmayın

اللغة العربية

حرصاً على سلامتك، يرجى عدم تجاوز أقصى حمولة

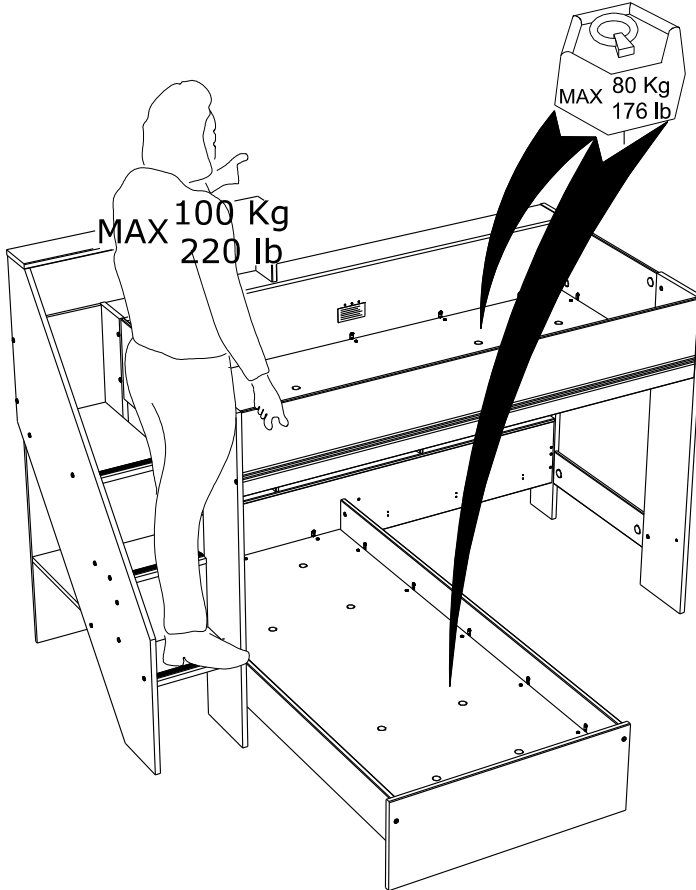

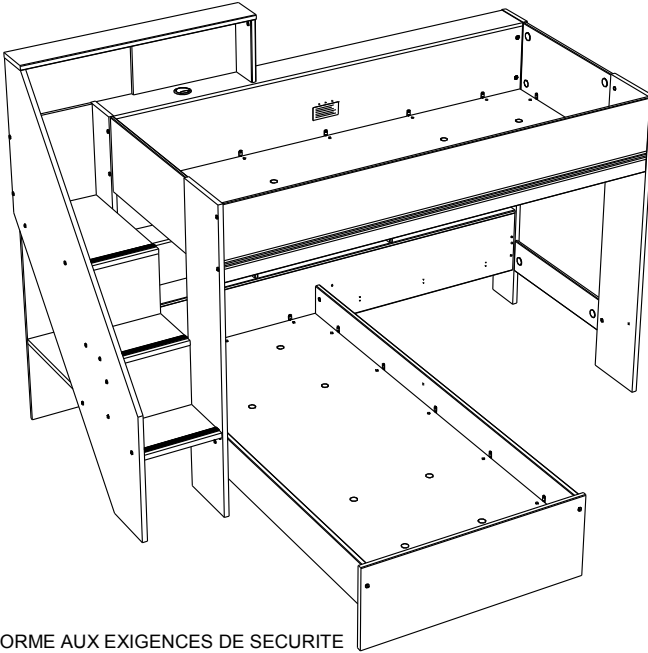

- FR** CONFORME AUX EXIGENCES DE SECURITE  
**EN** MEETS SAFETY STANDARDS  
**DE** ERFÜLLT DIE SICHERHEITSANFORDERUNGEN  
**ES** CONFORME A LAS NORMAS DE SEGURIDAD  
**PT** EM CONFORMIDADE COM OS REQUISITOS DE SEGURANÇA  
**IT** CONFORME AI REQUISITI DI SICUREZZA  
**NL** VOLDOET AAN DE VEILIGHEIDSNORMEN  
**CZ** VYHOVUJE BEZPEČNOSTNÍM POŽADAVKŮM  
**HU** A BIZTONSÁGI KÖVETELMÉNYEKNEK MEGFELEL  
**PL** WYRÓB SPEŁNIA WYMOGI BEZPIECZEŃSTWA  
**RO** CONFORM CU CERINȚELE DE SECURITATE  
**RU** СООТВЕТСТВУЕТ ТРЕБОВАНИЯМ БЕЗОПАСНОСТИ  
**SK** VYHOVUJE BEZPEČNOSTNÝM POŽIADAVKÁM  
**TR** GÜVENLİK KURALLARINA UYGUNDUR

يتوافق مع جميع اشتراطات السلامة

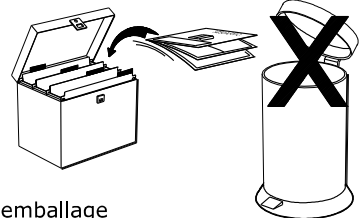

Faites un geste pour l'environnement en triant vos déchets d'emballage  
 Make a gesture for the environment by sorting out your waste of packaging  
 Machen Sie eine Bewegung für die Umwelt, ihre Verpackungsabfälle sortierend  
 Haga un gesto para el medio ambiente escogiendo sus residuos de embalaje