

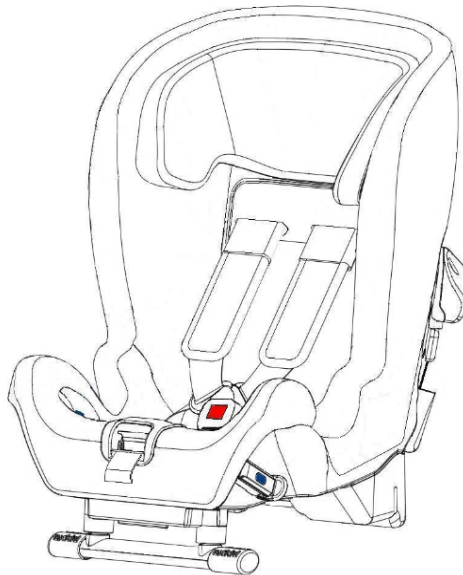

axkid

User's manual Minikid



Rear-facing, secured
with the car's seatbelt
9 to 25 kg

Tested and approved according

ECE R44 / 04

Important Information

Thank you for choosing a car seat from Axon Kids. Team Mini has more than 30 years experience in child safety, and we have done our best to make your car seat as safe as possible. It is of course approved according to the ECE R44 04, the latest European Test Standard for child safety.

In order to maximize the safety of your child it is important that you consider the following:

- Carefully read the instructions before installing the child safety seat. In case you are not sure whether you have installed correctly, you should contact your dealer who can show you how to install the seat correctly. Improper installation presents a hazard to your child.
- Never fit the car seat in a seat where any airbag is activated. If you still want to use that seat, then have the airbag(s) disconnected at an authorized workshop or disconnect with the car's own key shutdown, if available. Be careful to check that the car's indicator shows that the airbag is off.
- Have the child sit rear-facing as long as possible. Studies have shown that the risk of a child being killed in an accident is five times higher if the child seat is forward-facing.
- Always use the support column to mount your mini car seat. The support column is a very important safety feature designed to maximize your child's safety in a crash.
- Should you be involved in a car accident, no matter how small, always replace the car seat. It may have contracted invisible injuries that could severely affect your child's safety. Buy therefore never a used car seat either. Axon Kids recommends that you always buy a new chair in a retail store.



Read this manual before installing the car seat in the car.

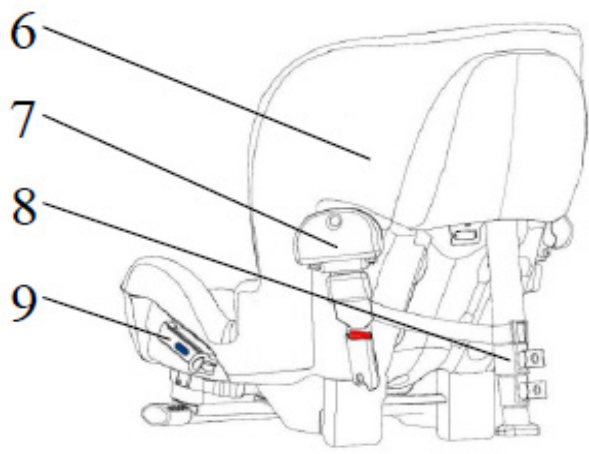
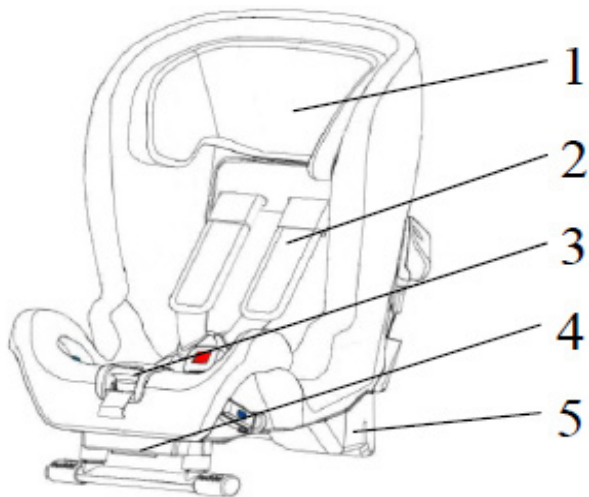

- 1 Headrest
- 2 Car seat's internal belt
- 3 Adjusting the car seat's internal belt
- 4 Adjusting the car seat's seat angle
- 5 Heel
- 6 Storage location of the manual
- 7 Anchor bands
- 8 Support column
- 9 Belt clip

Rear-facing with seat belt

Important to remember

If your child is to sit in the front seat, the airbag must be deactivated by an authorized workshop or by means of the car's own shutdown key, if available. Be careful to check that the car's indicator shows that the airbag is off.



Placing the chair

Your Mini can easily be lifted through the car door with its back first. Place the car seat in the car's seat and turn it so that the back is facing forward in the car. The chair's heels (1) must hook over the edge of the seat. The mark on the side of the heel should be in vertical line with the edge of the car seat.

If you have a small car, and the child is small enough to not require extra leg space, you may instead put the car seat with the heel on the car's seat.

When mounting in the car's front seat, the car seat's backrest may, but need not, have contact with the dashboard.

Press the adjustment handle for the sitting angle (2) in the direction of the chair's foot rest. With the adjustment handle in the open position, you can adjust the chair and select one of the five tilt positions. Choose an angle that is as upright as possible, but the child should be able to self-sustain its head, and the child's head should not hang forward if

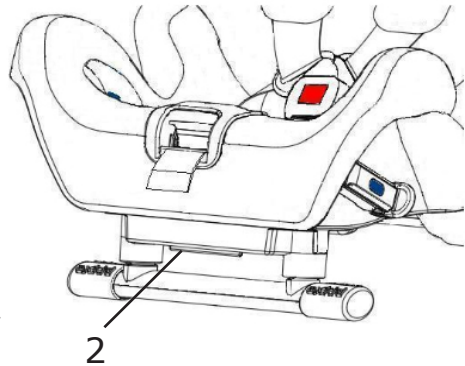
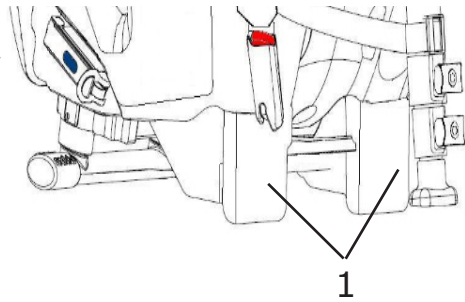

Continued on next page



Never use the car seat in a car where the airbag is activated.

the child should fall asleep. Rule of thumb is that the older the child gets, the more upright you can put the seat. Also note that the chair will be angled down slightly when it is clamped in the seat belt and sinking into the car's seat.

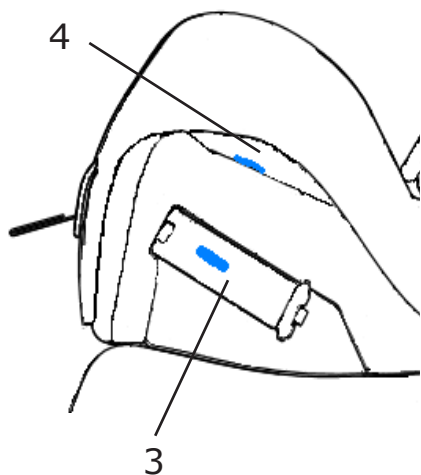

Attach the car's seat belt

Open both belt clips (3) of the chair. Grasp the seat belt and pull it out a bit to allow for mounting as shown below. The hip section of the belt must be at least 70 to 80 cm long.

Place then the belt through the hole in the belt clip (4) and push it underneath the fabric until it comes out on the other side. If you prefer you can pull the belt across the fabric.

Fasten the belt. Tighten securely, the belt that goes through or over the seat should be tight everywhere. Attach the belt in the belt buckle. Both the hip and shoulder belt should be fastened in the clip closest to the car's seat belt buckle. Only the hip belt should be fastened in the clip farthest to the car's seat belt buckle.

*Skip this part
if your car is
equipped with
attachment loops*



Attach the tether straps

Your vehicle may have two loops at the front seat rails, or in case the seat is mounted in the front seat, in front of the seat.

When there are no loops in your car the supplied fixing band that is lying in the chair should be used instead. If you installed the seat in the back seat pass the one end through either the rear of the front seat rails or other suitable attachment point on the front seat. The loop should be as close to the floor as possible. Use therefore a strap with a suitable length, and pass the loop through one of the band openings.

Continued on next page

Pull out the band from the retractor (1) to a suitable length. Check that the white markings on the bands are visible (2), if not, try to cross the straps thereby making them a bit longer so that the white markings are visible. Attach the interface in the car's or attachment belt loop. Repeat on the other side. Wiggle the chair lightly from side to side a few times.

Fold out the support column (3) to its outermost position. Pull the latch on the top height adjuster (3) and pull down the column so that it makes contact with the car floor. In case the support column is not long enough, repeat use of the lower height adjuster (4). Wiggle the chair from side to side once again, this time somewhat stronger. The retractor will then be tensioned automatically.

If you have installed the car seat in the car's back seat, move now your vehicle seat in front of it to a comfortable position. The back of the car's seat may, but need not, be in contact with the car seat.

Adjust the seat belt

Place the child in the car seat. Place the child's arms in between the shoulder straps so that the straps hang over the baby's chest and stomach. Assemble the shoulder straps and fasten them in the seat belt between the child's legs.

Pull the adjustment belt (5). The belt is tensioned and the headrest automatically slides down to the correct height. To loosen the ties, hold down the belt adjustment button and pull both belts just below the cuffs.

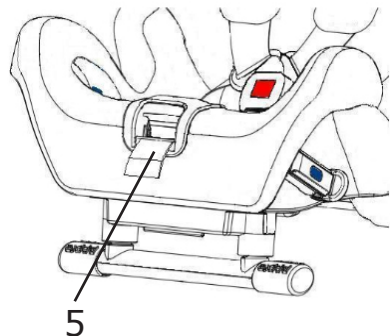
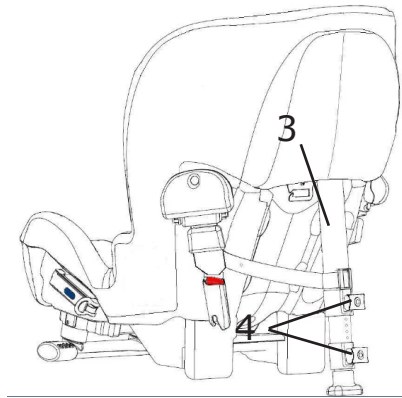
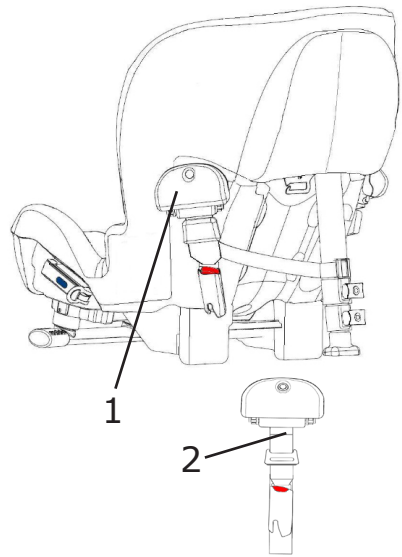

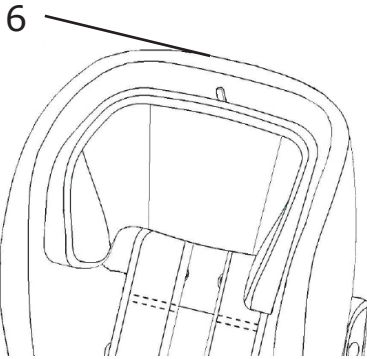

Supplement for headrest adjustment

The headrest on your mini is equipped with a parking brake. To activate the parking brake, pull down the headrest to the desired height. Release the headrest until you hear a "click" sound from the chair, make sure that the headrest can not be pulled down. Activate the brake by moving the lever (6) on the headrest to the right. Do not pull up the headrest with the parking brake activated.

Guarantee and maintenance

- If the child seat upholstery is to be replaced use only original products from Axon Kids. If other products are used this could jeopardize the entire seat's safety and can lead to serious injury or death in the event of an accident.
- The child seat's upholstery can be removed and machine washed. Use the hand washing program (max. 30 °C). Do not use a dryer as this may damage the upholstery. Never use the car seat without its cover.
- The plastic parts in the car seat can be cleaned but only with non-aggressive detergents such as plain soap. Cleaning solvents must not be used as this may damage the plastic and could thus also jeopardize the safety of the seat.
- The components in the child seat can be recycled and should be disposed according to local and national regulations that apply in your municipality.
- Do not make any repairs to the car seat on your own other than those described in this manual. Follow the instructions in this manual carefully.
- Guarantee provided according to the Swedish Consumer agency's recommendations. Always save your receipt and bring it and the car seat to your dealer in case of any errors.
- All the used materials maintain very high standards of resistance to UV radiation (sunlight). Despite this, the UV radiation from the sun is very aggressive and will ultimately result in the fabric becoming pale. This is not covered under warranty and is considered normal wear.
- Never leave your child unattended in the car seat.
- Be sure to secure any cargo in the car so that it does not harm your child or yourself in a collision.
- Keep this manual in the designated pocket of the car seat.