

0636CONS

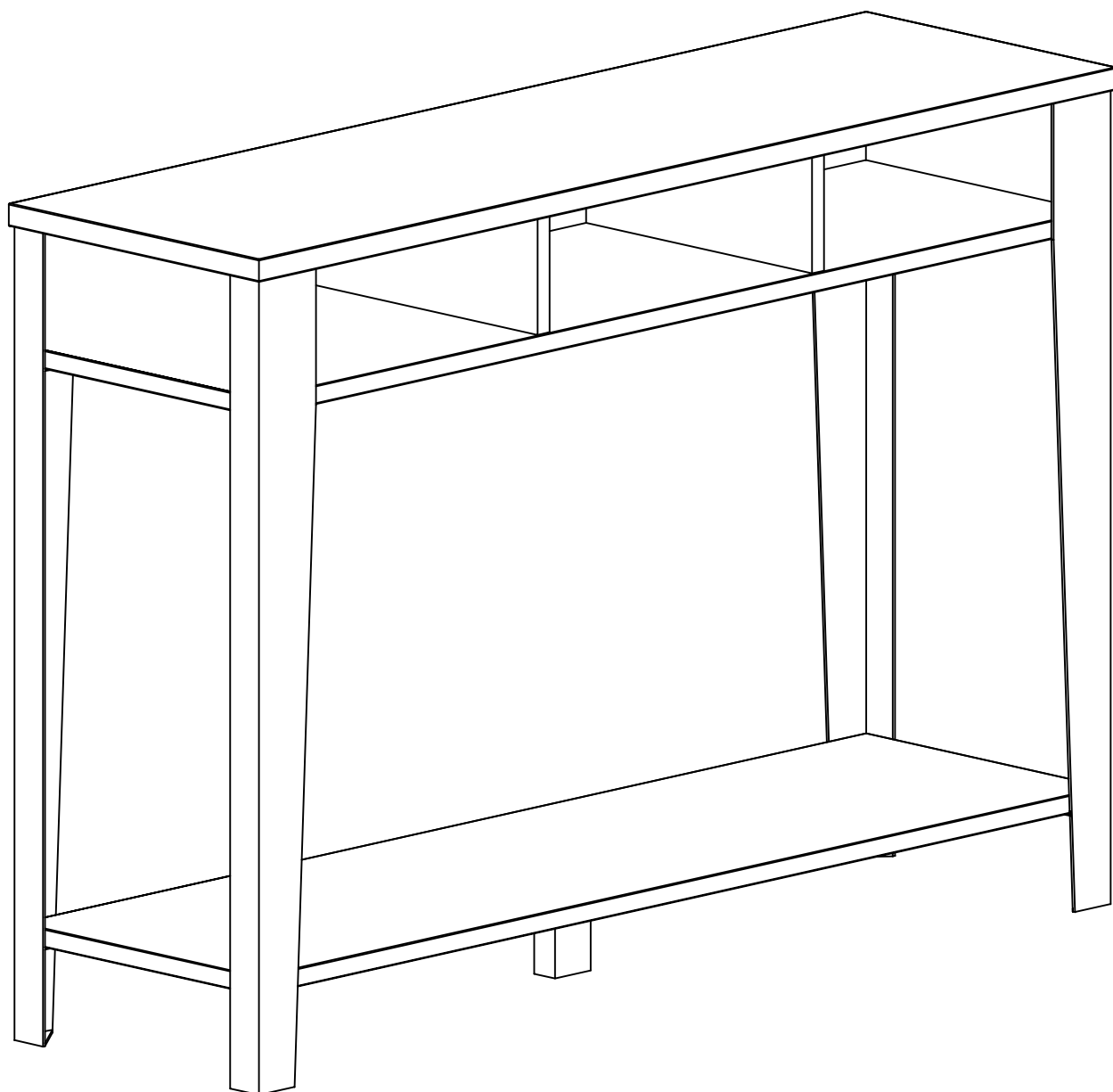

Décor/Finitions: Chêne nature 013

Gamme: FORGE

FR Remerciements:

Nous vous remercions d'avoir choisi un meuble créé et fabriqué par le Artemob International et espérons qu'il vous donnera entière satisfaction

EN Thanks:

Thank you for choosing furniture designed and manufactured by the Artemob International. We hope you are totally satisfied with your purchase

DE Danksagung:

Wir danken Ihnen für den Kauf eines Frankreich von der Artemob International entworfenen und hergestellten Möbelstücks und hoffen, dass Sie es zu Ihrer vollkommenen Zufriedenheit finden werden

ES Agradecimientos:

Les damos las gracias por haber elegido un mueble diseñado y fabricado por el Artemob International y esperamos que sea de su total agrado.

PT Agradecimentos:

Obrigado por ter escolhido um móvel concebido e fabricado pelo Artemob International, esperando que seja do seu inteiro agrado.

IT Ringraziamenti:

Grazie per avere scelto un mobile progettato e fabbricato dal Artemob International. Speriamo soddisfi appieno le vostre esigenze.

NL Bedankje:

Wij bedanken u voor de aankoop van een door de Artemob International ontworpen en vervaardigd meubel en hopen dat u er veel plezier aan zult beleven.

RU Благодарность:

Мы благодарим вас за то, что вы выбрали мебель, созданную и произведенную Artemob Интернационал, и надеемся, что вы будете полностью удовлетворены нашей продукцией.

PL Podziękowania:

Dziękujemy za wybór mebli stworzonych i wyprodukowanych przez Artemob International. Mamy nadzieję że będziecie Państwo w pełni zadowoleni z zakupu.

SK Pod'akovanie:

Ďakujeme, že ste si vybrali nábytok navrhnutý a vyrobený spoločnosťou Artemob International. Dúfame, že budete svojím nákupom absolútne spokojní.

CS Poděkování:

Děkujeme, že jste si vybrali nábytek navržený a vyrobený společností Artemob International. Doufáme, že budete svým nákupem naprosto spokojeni.

HU Köszönet:

Köszönjük, hogy a Artemob International által létrehozott és gyártott bútort választott, reméljük, hogy elégedett lesz a termékkel.

RO Mulțumiri:

Vă mulțumim că ați ales un articol de mobilier conceput și fabricat de Artemob International și sperăm că veți fi pe deplin satisfăcuți de acesta.

TR Teşekkür ederiz:

Artemob International tarafından tasarlanan ve üretilen bu mobilyayı seçtiğiniz için teşekkür ederiz. Ürününüzden memnun kalmanızı ümit ederiz.

AR شكر:

باريزو نشكرکم لاختيارکم هذه القطعة من الأثاث من تصميم وتنمى أن تنال Artemob International وتصنيع مجموعة رضاهم.

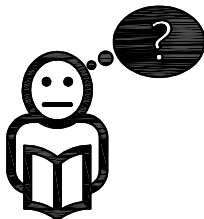
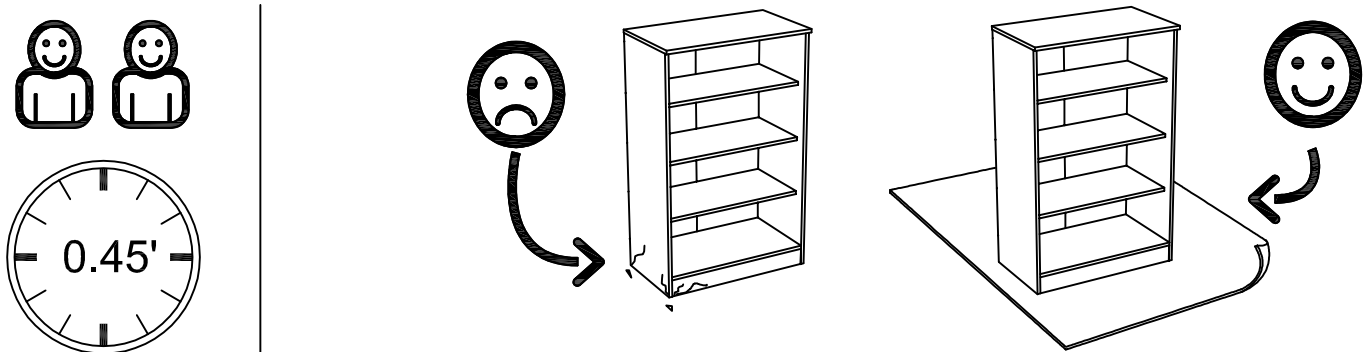
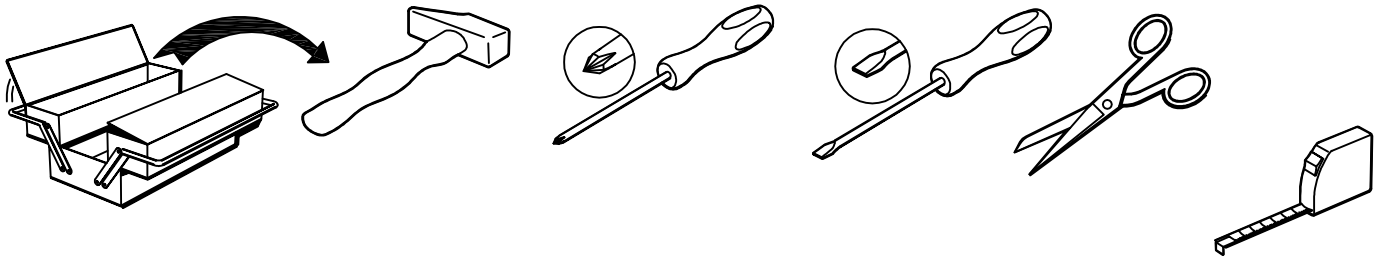

contact@artemobinternational.com

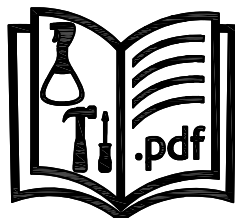

www.artemobinternational.com

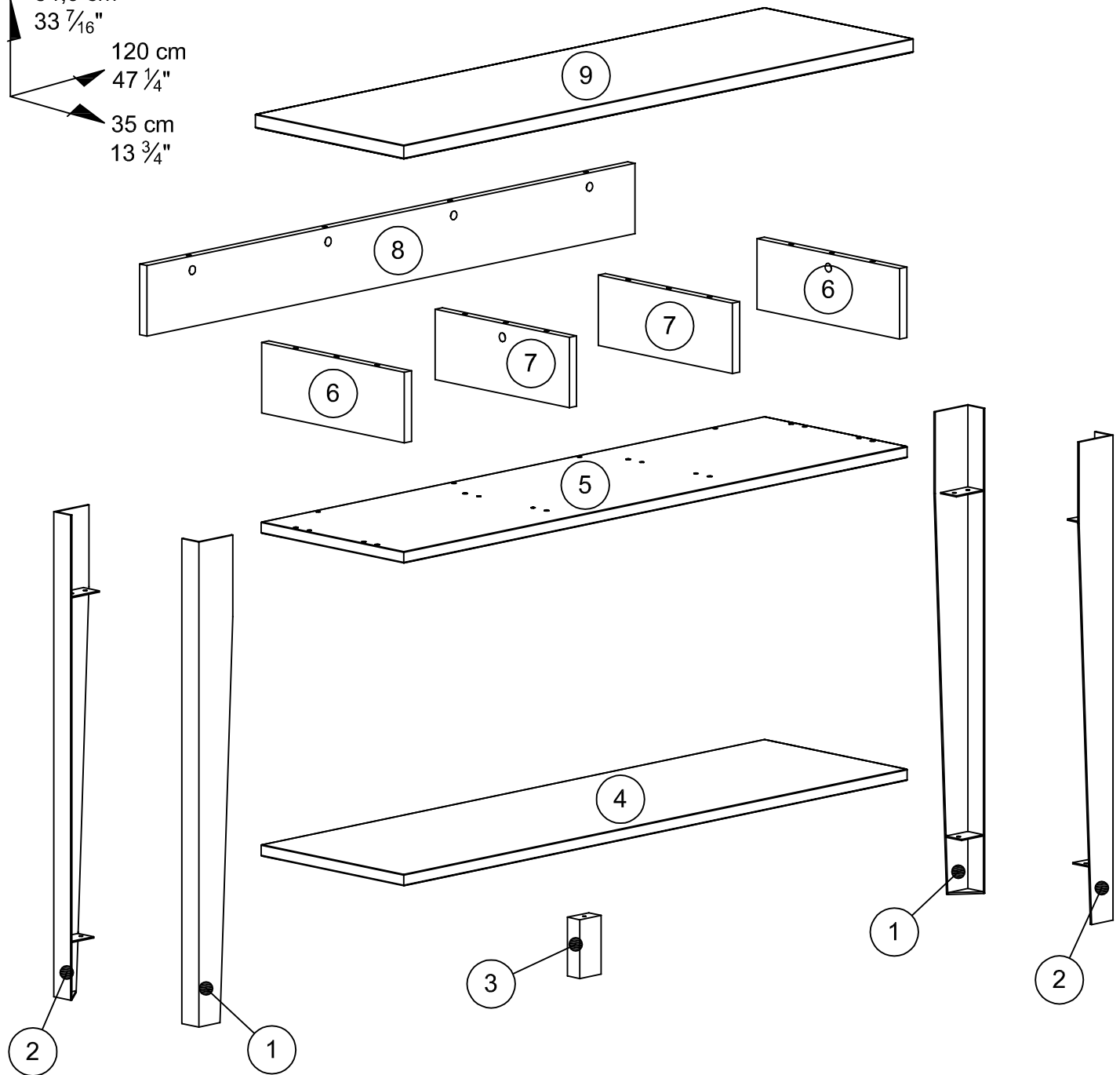
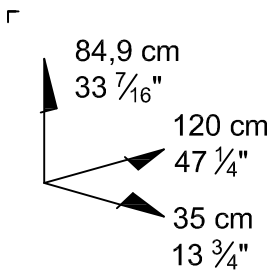

0636CONS		mm			inch			
①	x 2	826	80	40	32 1/2	3 1/8	1 9/16	
②	x 2	826	80	40	32 1/2	3 1/8	1 9/16	
③	x 1	100	50	29	3 15/16	1 15/16	1 1/8	
④	x 1	1186	336	19	46 11/16	13 1/4	3/4	
⑤	x 1	1186	336	19	46 11/16	13 1/4	3/4	
⑥	x 2	120	336	17	4 3/4	13 1/4	11/16	
⑦	x 2	120	316	17	4 3/4	12 7/16	11/16	
⑧	x 1	1150	120	17	45 1/4	4 3/4	11/16	
⑨	x 1	1200	350	23	47 1/4	13 3/4	7/8	

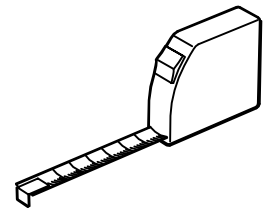

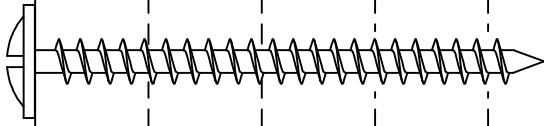
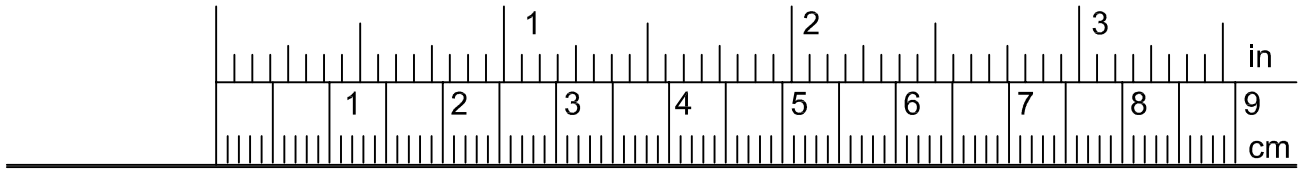

SY x 1

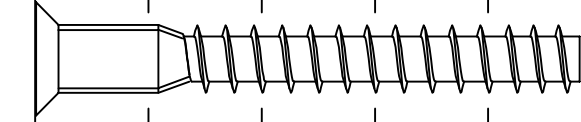
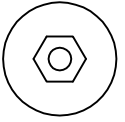

HW x 12

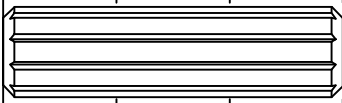
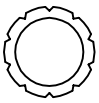

ADM x 16

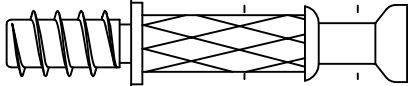

BWC x 8

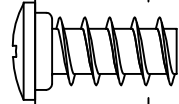

VB x 12



Ai x 8

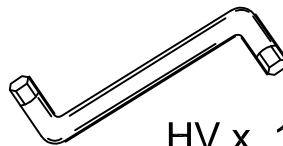

HV x 1



ZLR x 8

1

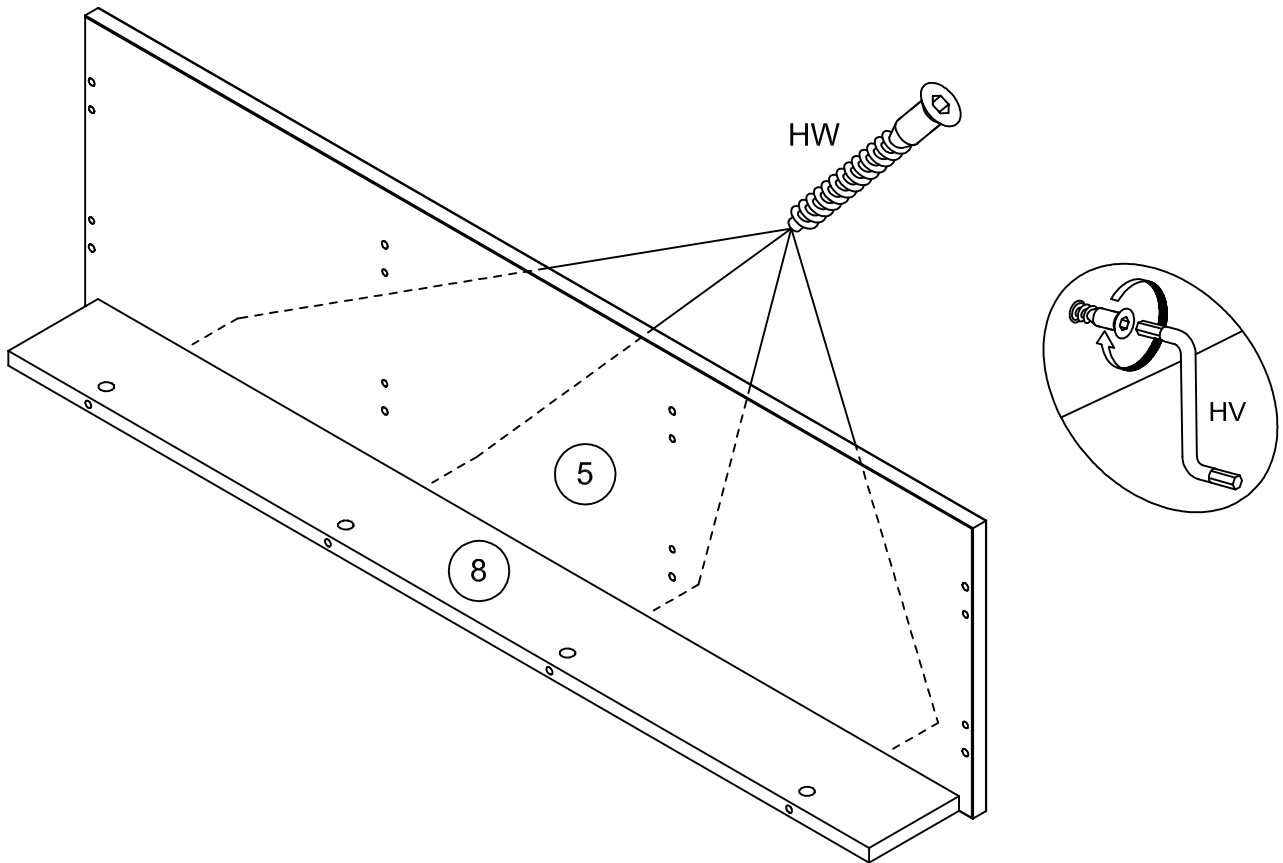
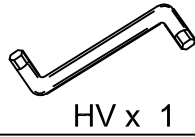
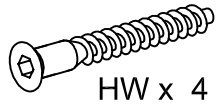

2

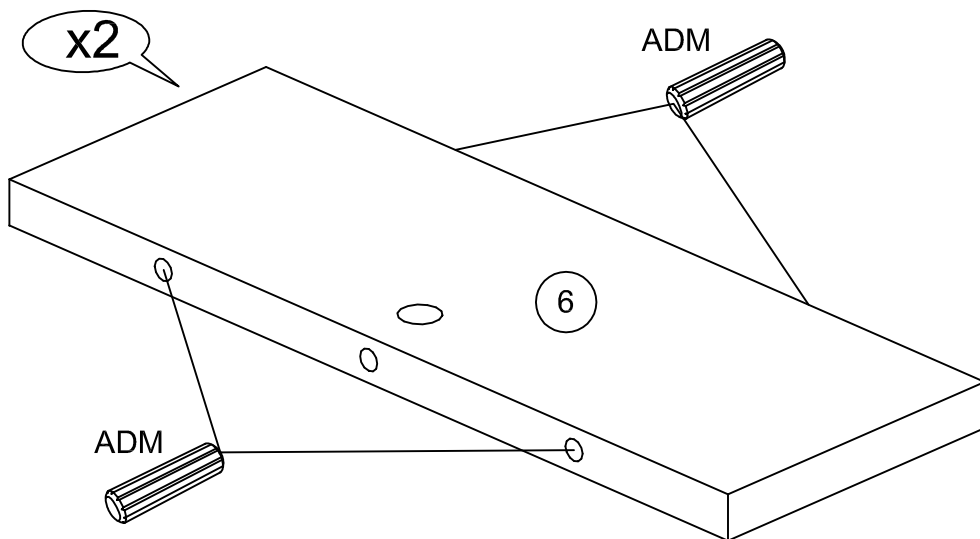
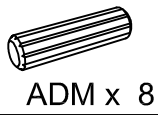

3

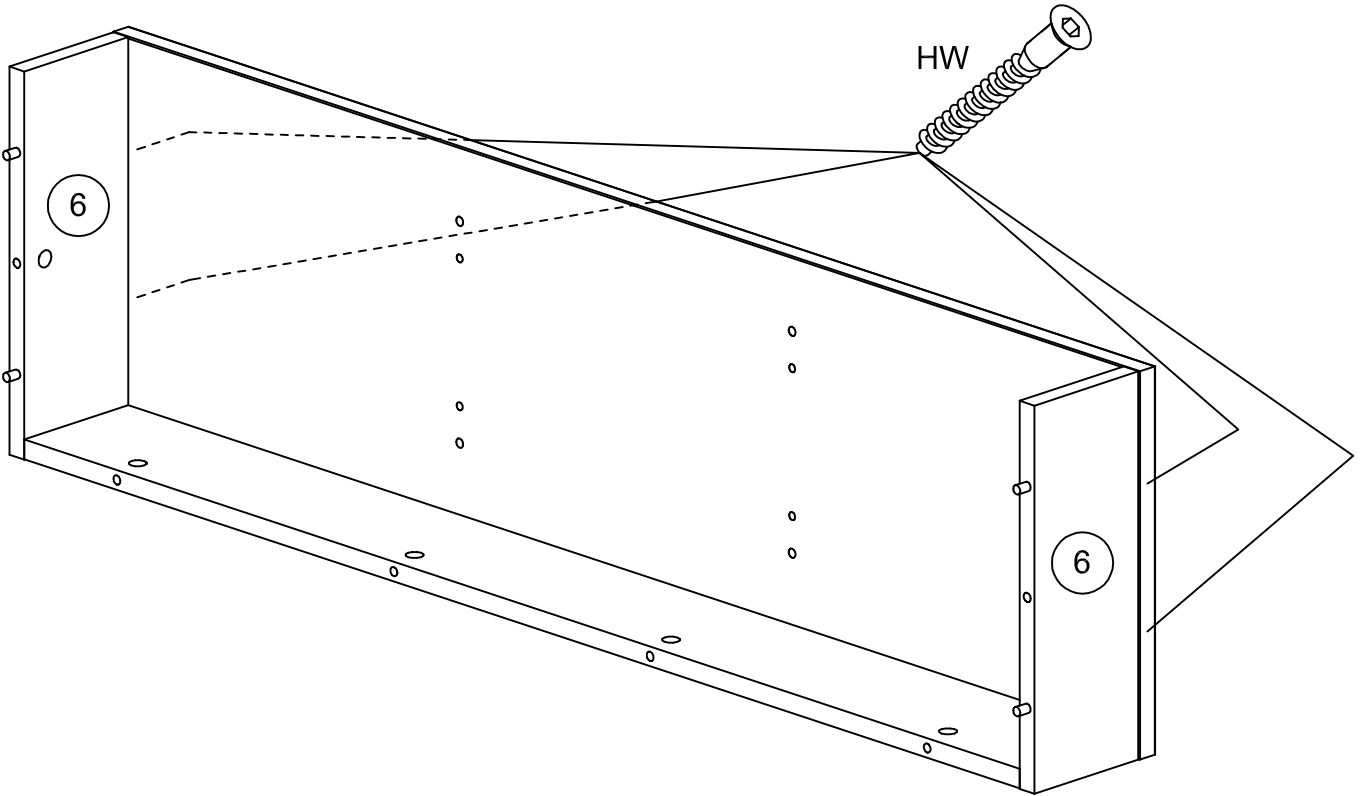
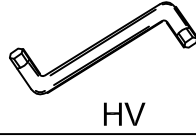
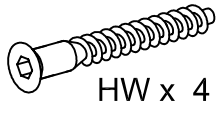

4

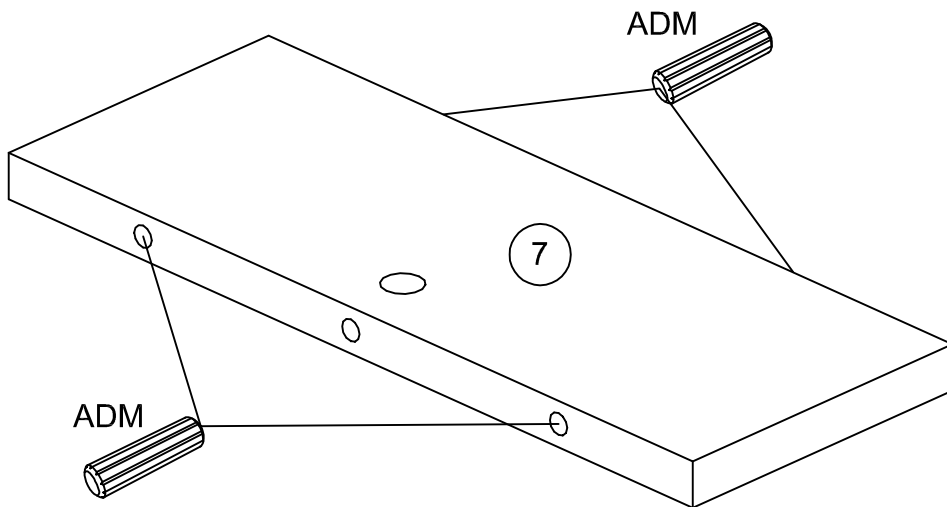
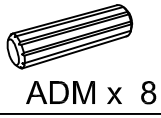

5

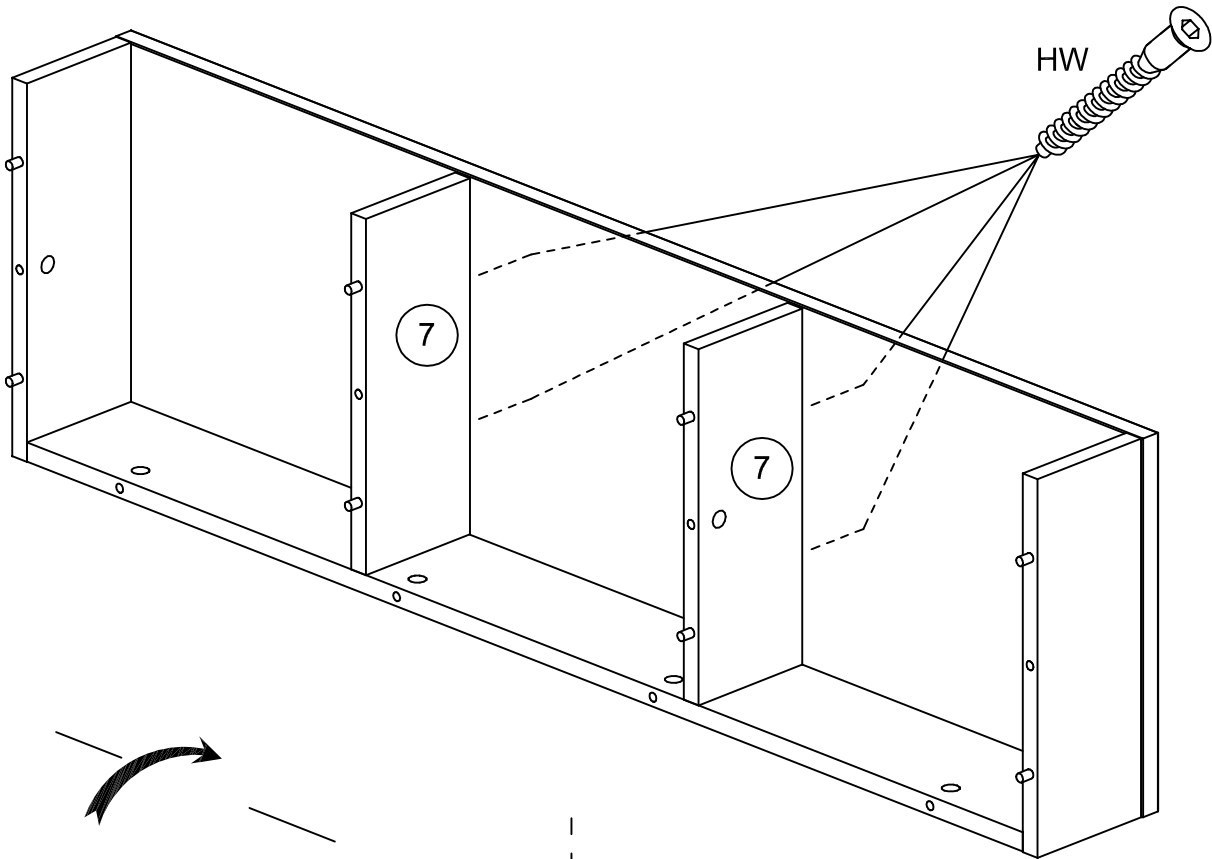
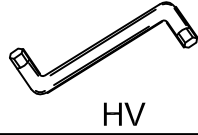
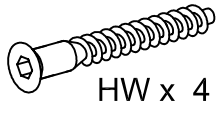

6

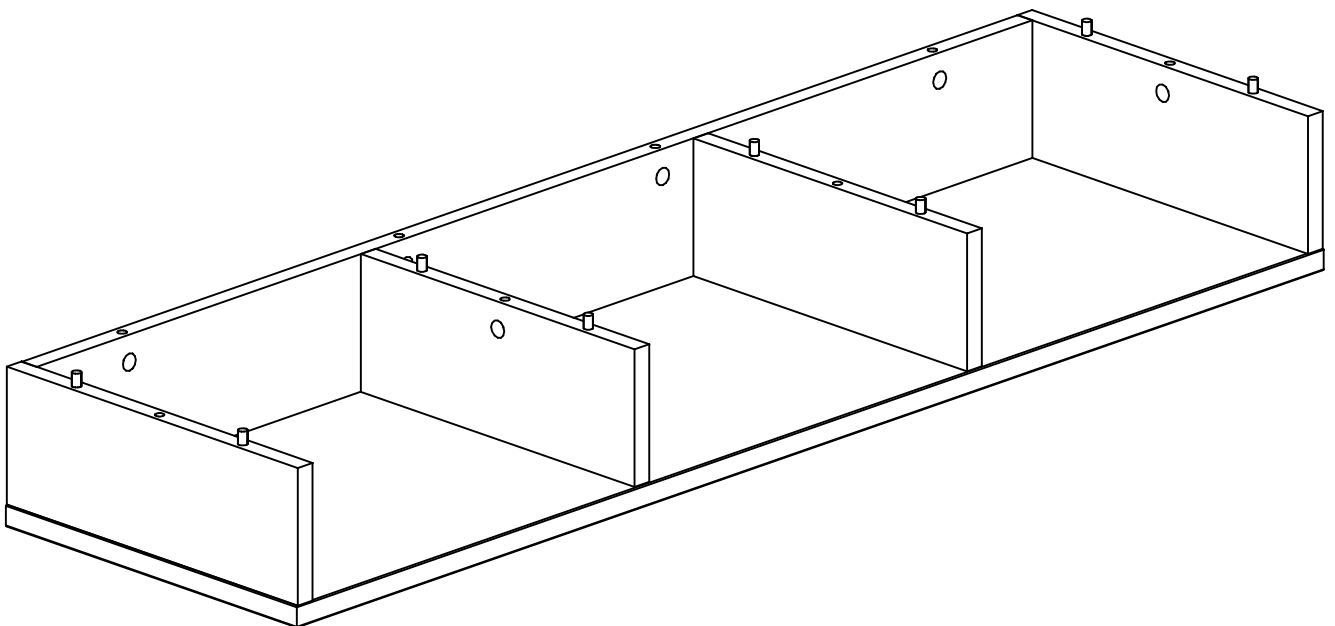
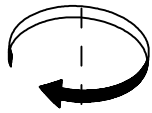

7

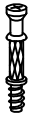

BWC x 8

0098A.7

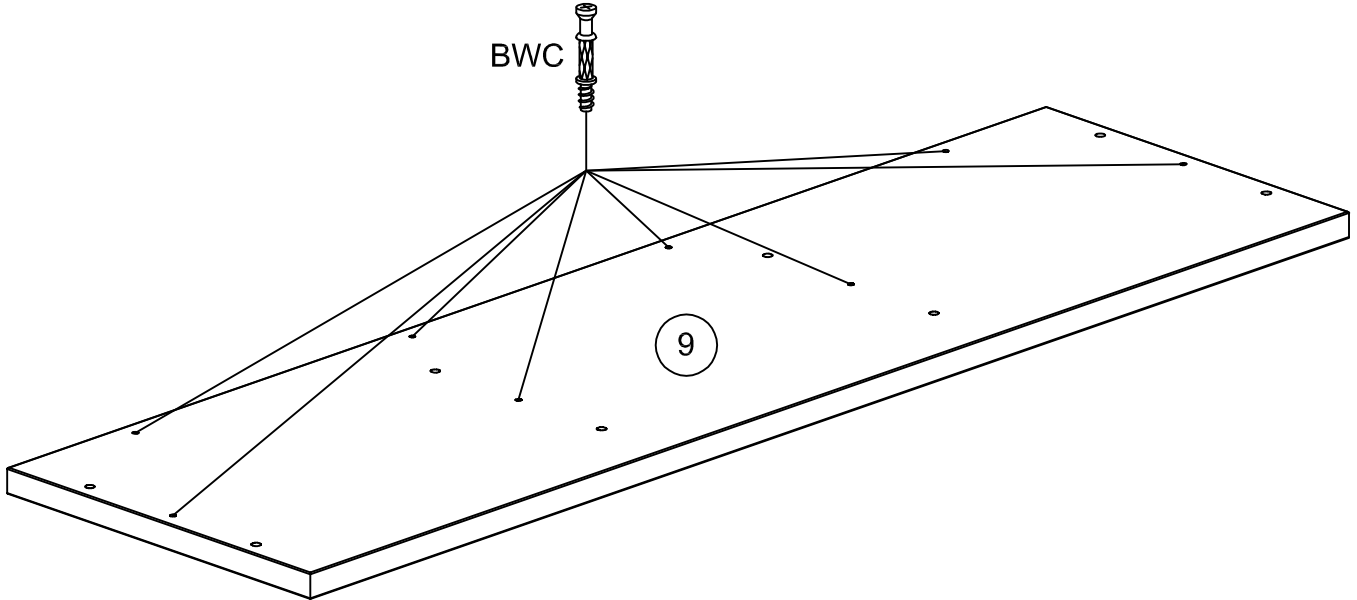

8



Ai x 8

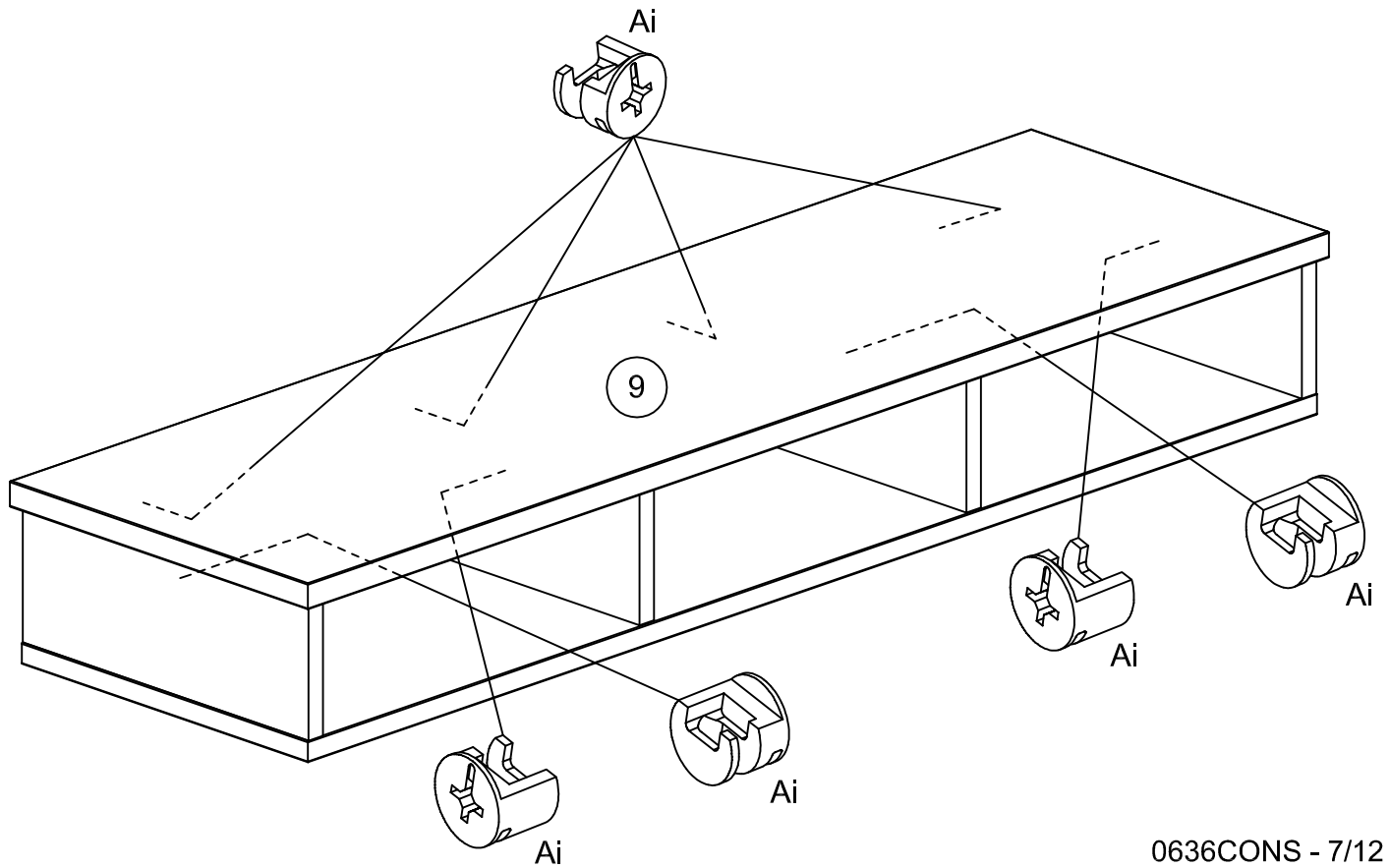

0636CONS - 7/12_

9

ZLR x 8

0098A.7

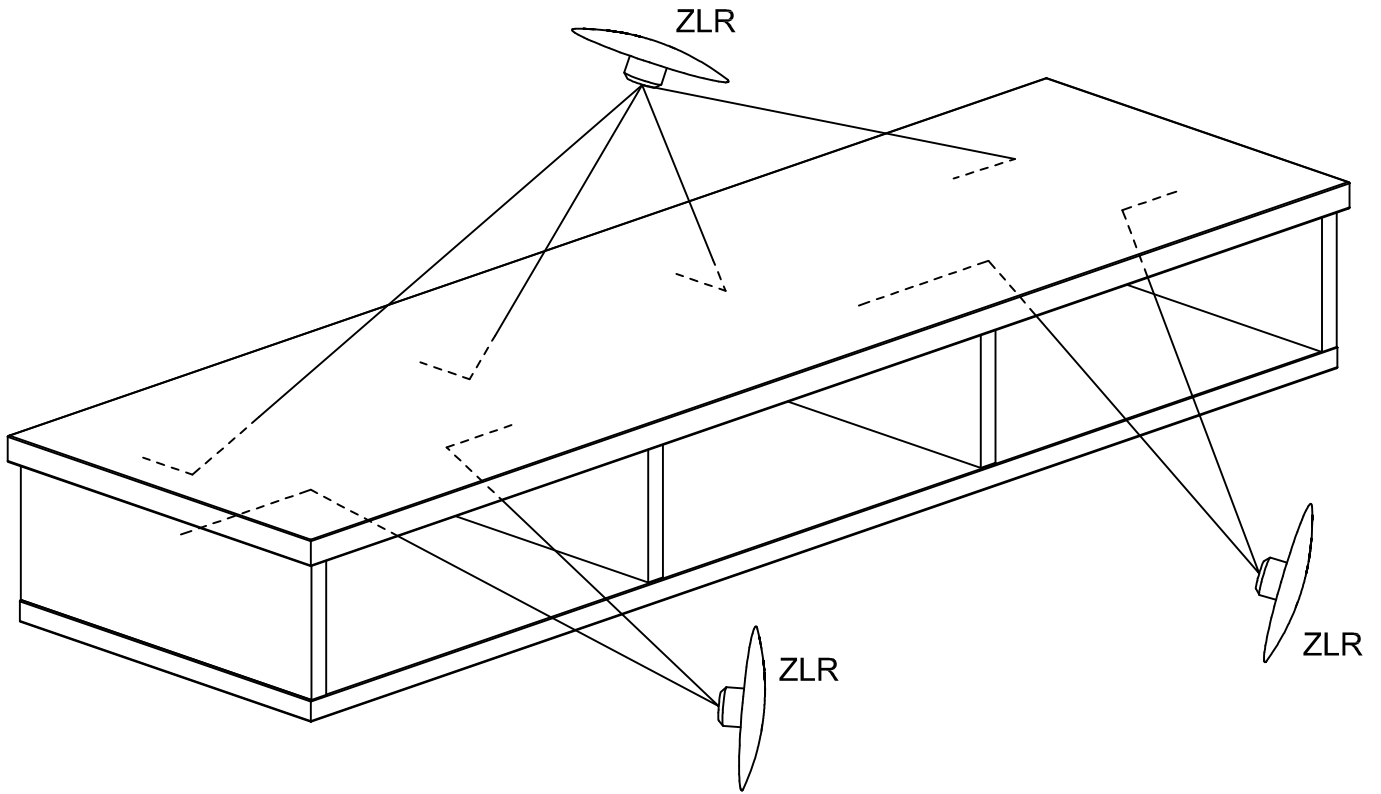

10

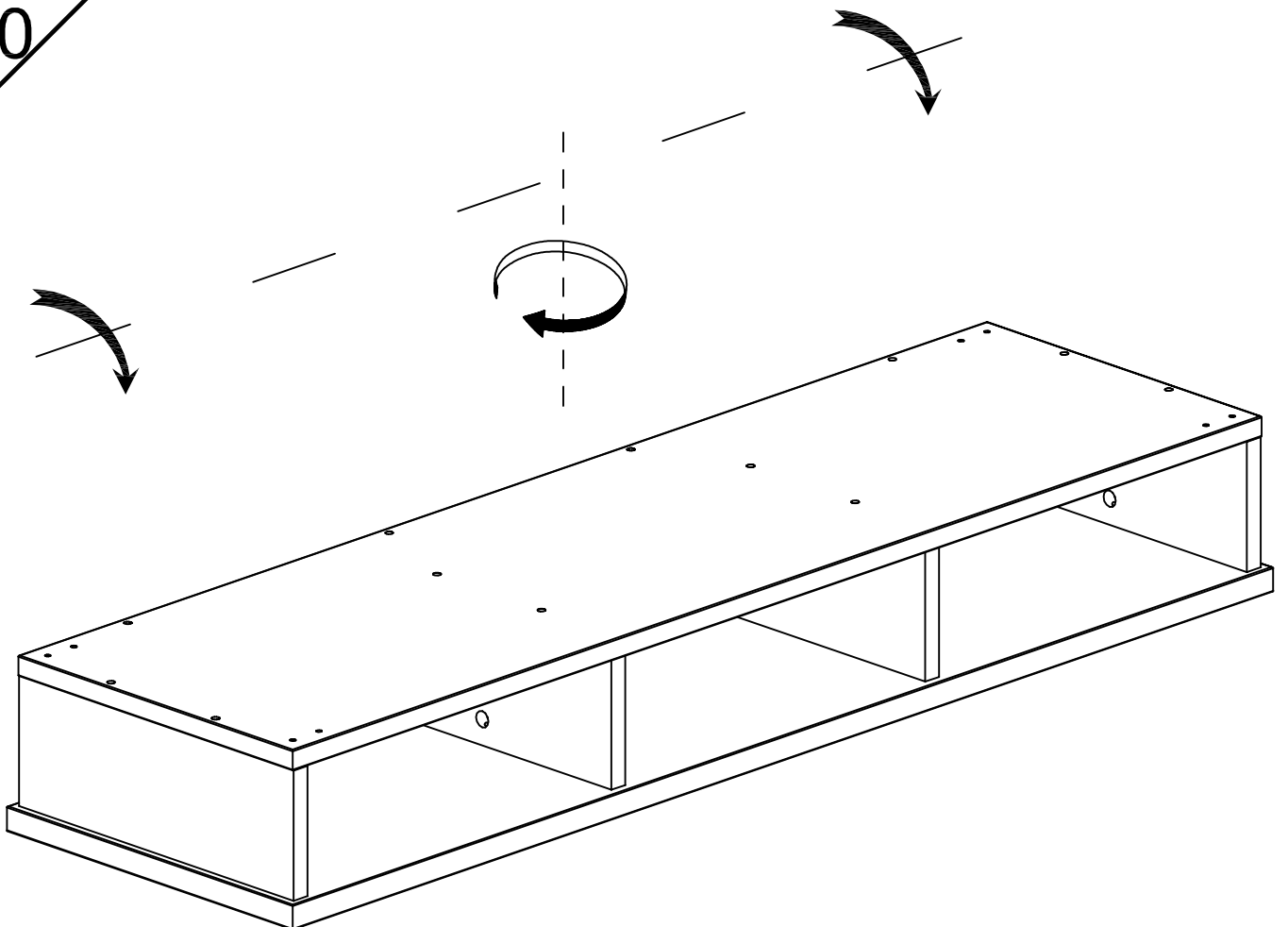

0636CONS - 8/12_



11

0098A.7

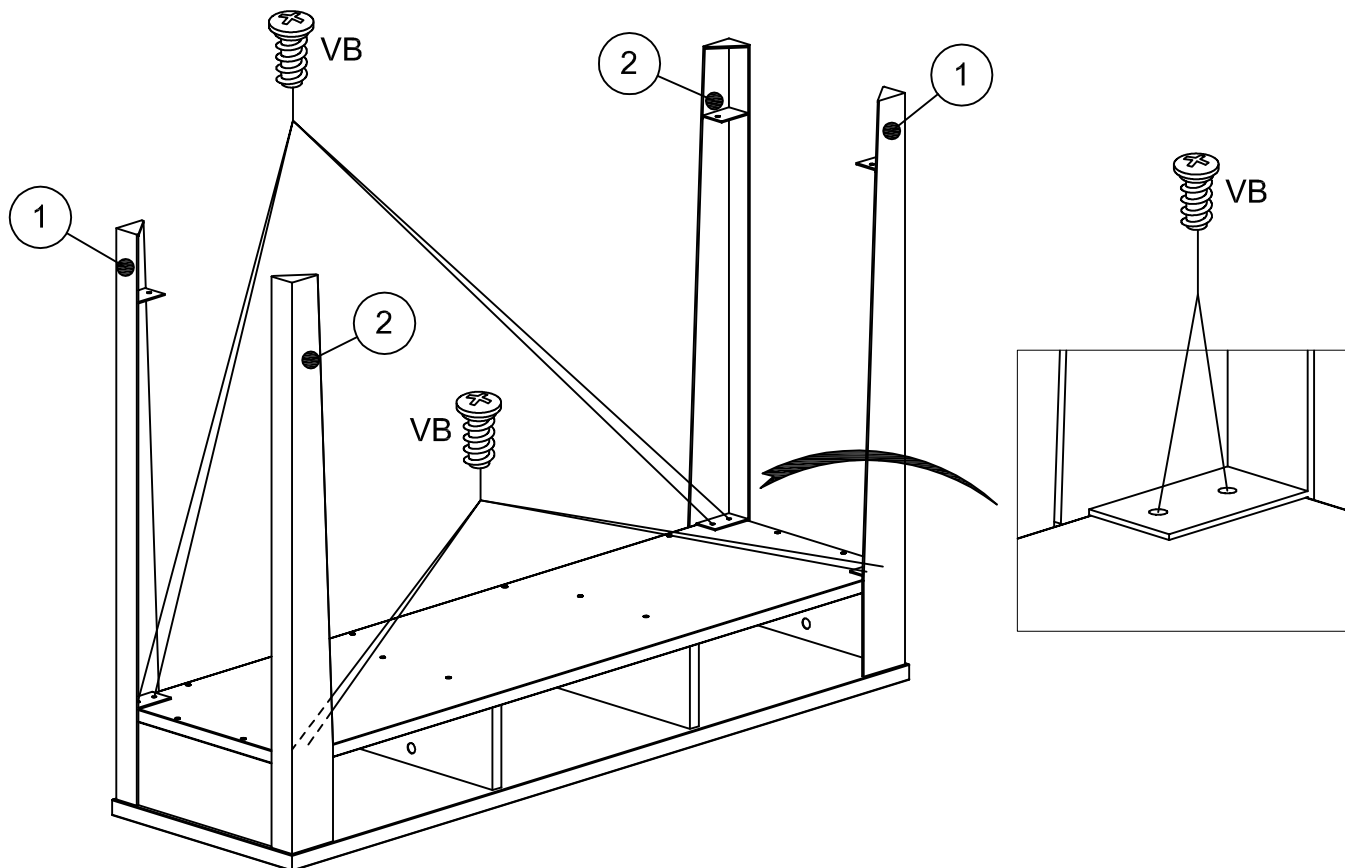
VB x 8



12

 
SY x 1

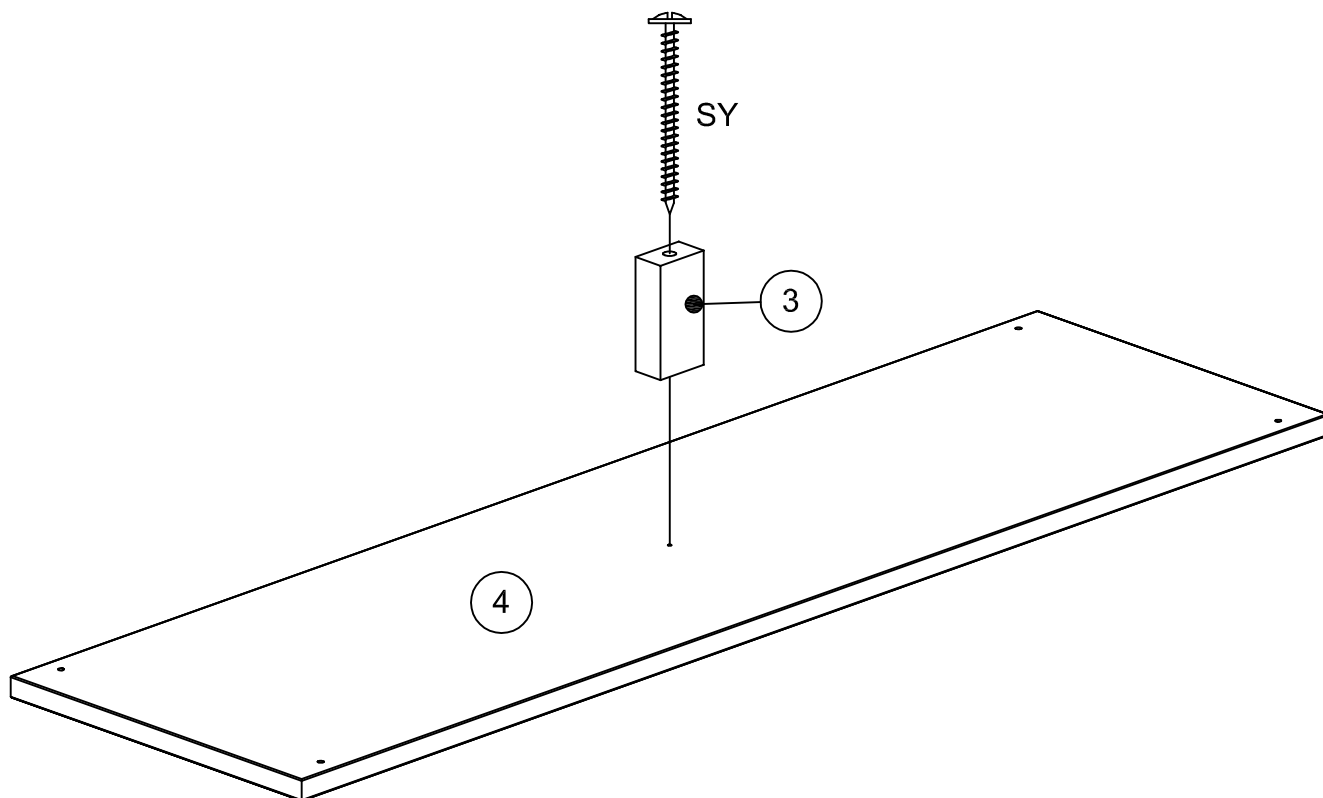

13



VB x 4

0098A.7

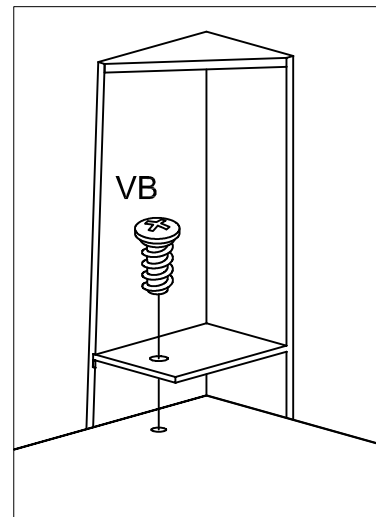
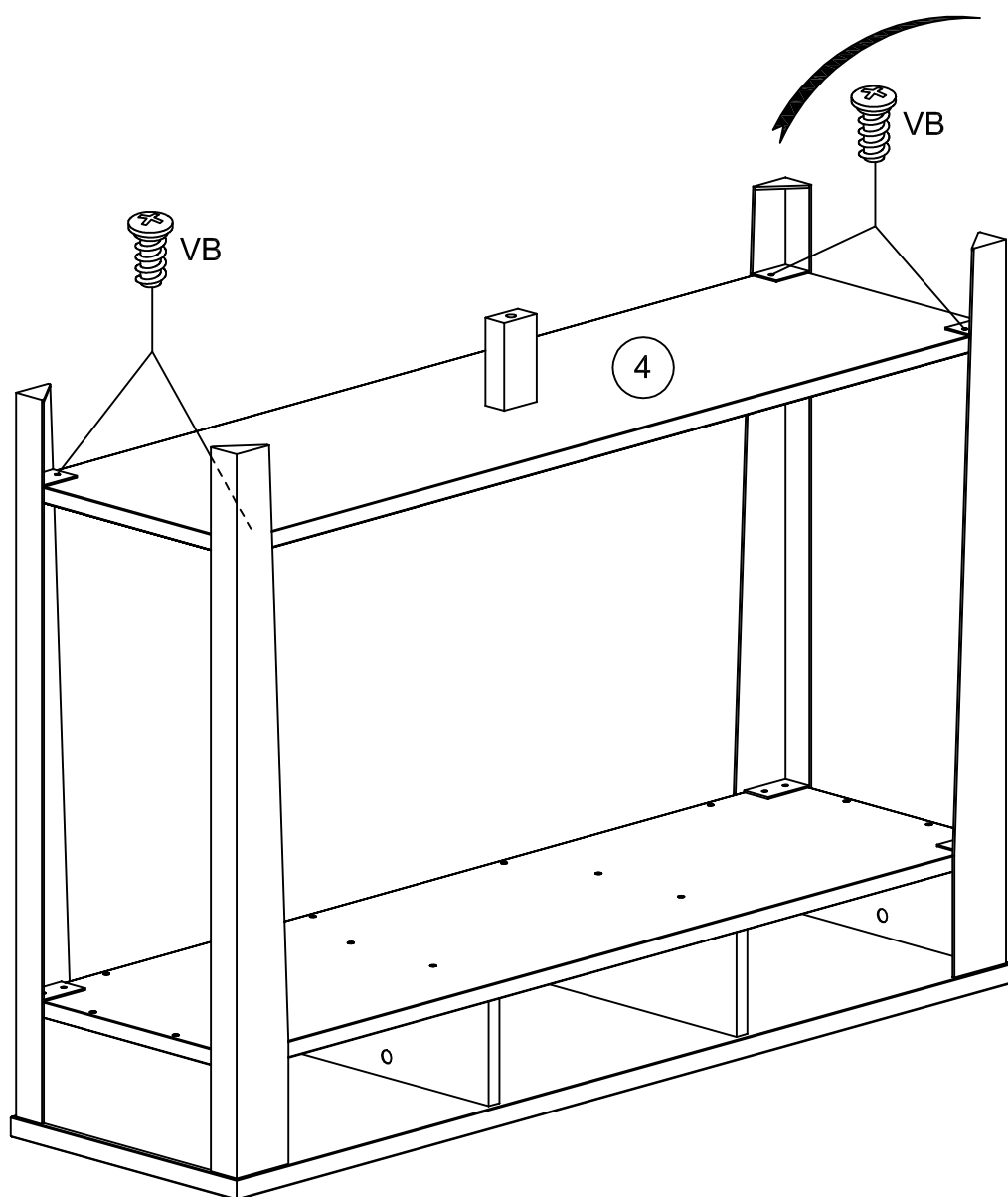

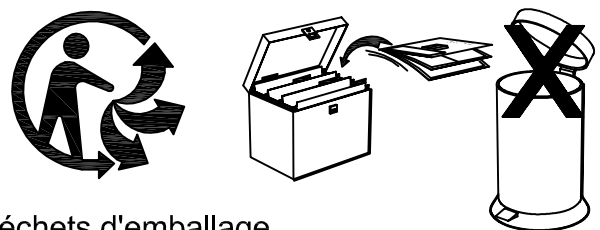
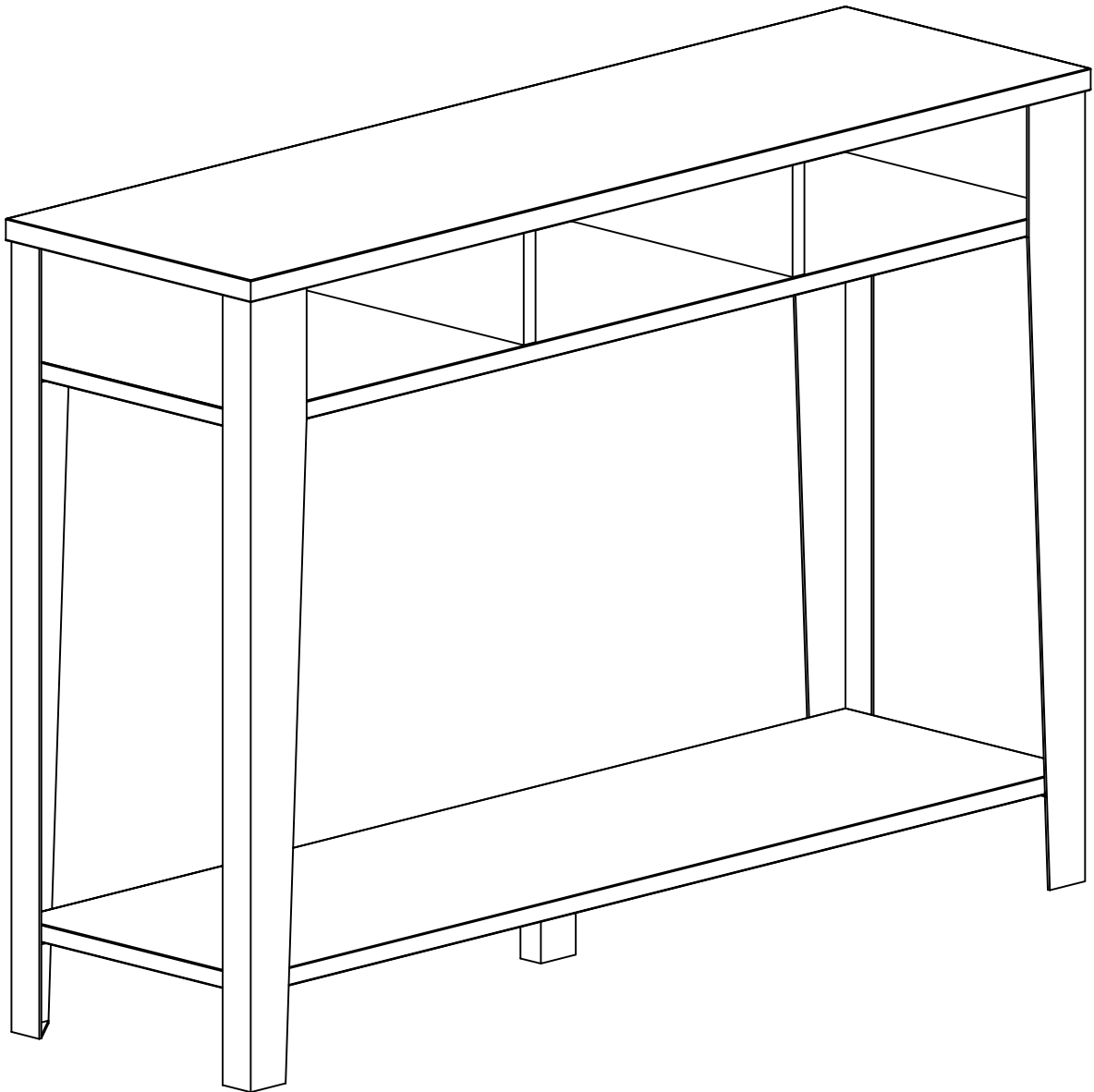

Faites un geste pour l'environnement en triant vos déchets d'emballage
Make a gesture for the environment by sorting out your waste of packaging
Machen Sie eine Bewegung für die Umwelt, ihre Verpackungsabfälle sortierend
Haga un gesto para el medio ambiente escogiendo sus residuos de embalaje

Conseils d'usage pour l'entretien de votre meuble

Nettoyage :

- a) Ne jamais utiliser de chiffons abrasifs mais toujours un tissu doux et légèrement humide, éviter de frotter la surface fortement
- b) les produits de nettoyage doivent être des produits à base naturelle, jamais d'eau de Javel , d'alcool , de solvant, d'ammoniaque
- c) produits suggérés : eau avec léger savon naturel ou produits pour le verre .

Recommandations :

Resserrez les vis et les assemblages après quelques temps d'usage (lit, table, bureau, charnières).

Afin de prévenir d'inutiles pressions sur les points d'attache, nous vous recommandons de placer vos meubles sur une surface plane.

Si vous souhaitez déplacer votre meuble, pensez à le vider et enlever les tablettes verres. Sans cela, vous pourriez abimer le meuble et le sol.

Si vous posez des casseroles, cafetières, tasses, etc. nous vous recommandons d'utiliser des dessous de plats.

Si vous renversez un liquide, utiliser immédiatement un chiffon sec pour essuyer la surface jusqu'à ce qu'elle soit entièrement sèche.

Recommandations spécifiques pour les meubles hauts :

Pour des raisons de sécurité, tous les meubles hauts disposent d'un dispositif d'accrochage au mur, disponible à l'intérieur de votre colis. Si tel n'est pas le cas, veuillez en faire la demande auprès de votre revendeur. Cela empêche toute chute accidentelle du meuble.

La qualité de nos produits et votre entière satisfaction, font l'objet de toute notre attention. En cas de questions ou de remarques, n'hésitez pas à en faire part à votre revendeur.

Nous espérons que ce meuble vous apportera entière satisfaction.