

5940BURE

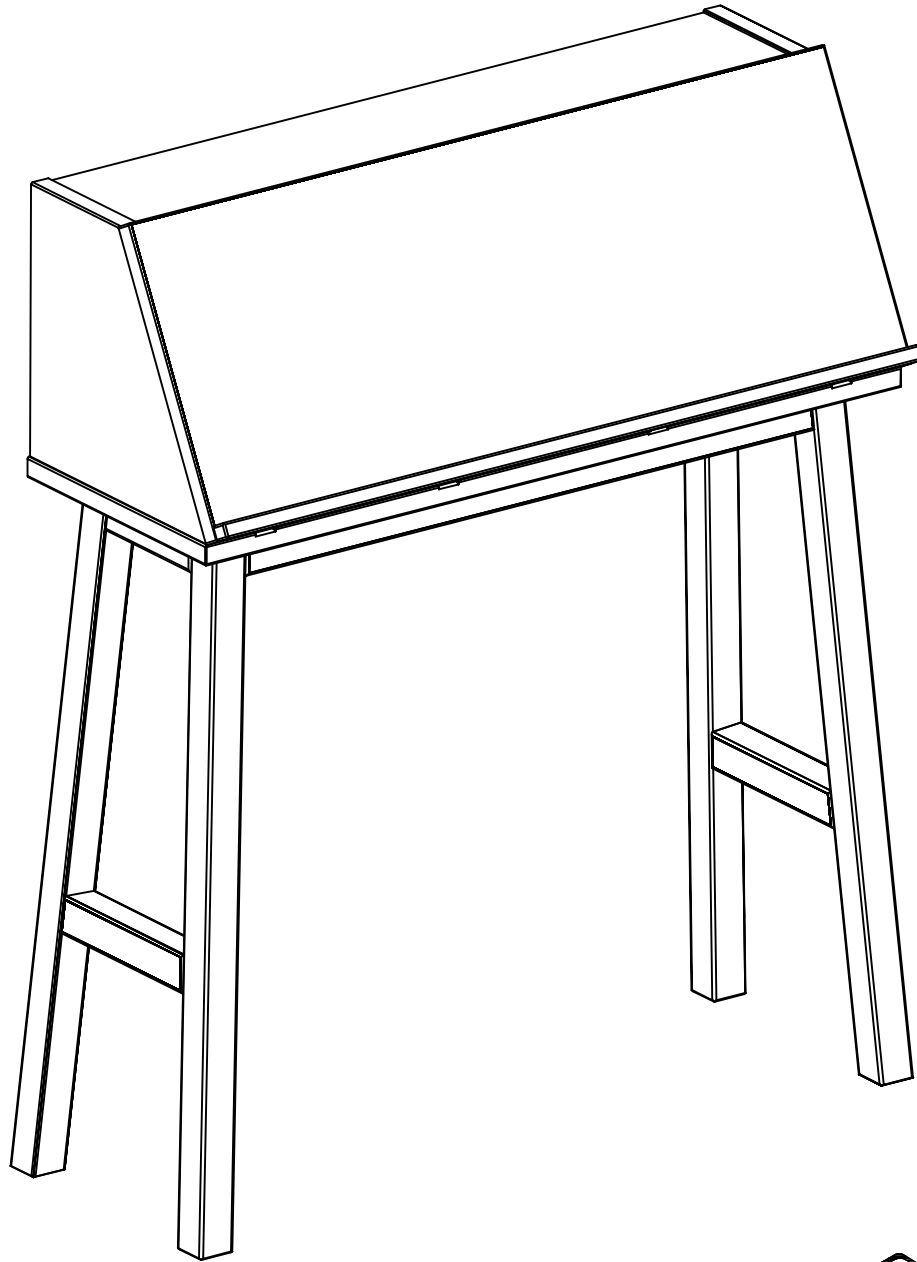

GREEN
way



FR Remerciements :

Nous vous remercions d'avoir choisi un meuble créé et fabriqué par le Groupe Parisot et espérons qu'il vous donnera entière satisfaction

IT Ringraziamenti:

Grazie per avere scelto un mobile progettato e fabbricato dal Gruppo Parisot. Speriamo soddisfi appieno le vostre esigenze.

CS Poděkování:

Děkujeme, že jste si vybrali nábytek navržený a vyrobený společností Parisot Group. Doufáme, že budete svým nákupem naprosto spokojeni.

EN Thanks:

Thank you for choosing furniture designed and manufactured by the Parisot Group. We hope you are totally satisfied with your purchase

NL Bedankje:

Wij bedanken u voor de aankoop van een door de Groep Parisot ontworpen en vervaardigd meubel en hopen dat u er veel plezier aan zult beleven.

HU Köszönet:

Köszönjük, hogy a Parisot Groupe által létrehozott és gyártott bútort választott, reméljük, hogy elégedett lesz a termékkel.

DE Danksagung:

Wir danken Ihnen für den Kauf eines Frankreich von der Parisot-Gruppe entworfenen und hergestellten Möbelstücks und hoffen, dass Sie es zu Ihrer vollkommenen Zufriedenheit finden werden

RU Благодарность:

Мы благодарим вас за то, что вы выбрали мебель, созданную и произведенную Групп Паризо, и надеемся, что вы будете полностью удовлетворены нашей продукцией.

RO Mulțumiri:

Vă mulțumim că ați ales un articol de mobilier conceput și fabricat de Grupul Parisot și sperăm că veți fi pe deplin satisfăcuți de acesta.

ES Agradecimientos:

Les damos las gracias por haber elegido un mueble diseñado y fabricado por el Groupe Parisot y esperamos que sea de su total agrado.

PL Podziękowania:

Dziękujemy za wybór mebli stworzonych i wyprodukowanych przez Grupę Parisot. Mamy nadzieję, że będziecie Państwo w pełni zadowoleni z zakupu.

TR Teşekkür ederiz:

Parisot Group tarafından tasarlanan ve üretilen bu mobilyayı seçtiğiniz için teşekkür ederiz. Ürünümüzden memnun kalmanızı ümit ederiz.

PT Agradecimentos:

Obrigado por ter escolhido um móvel concebido e fabricado pelo Grupo Parisot, esperando que seja do seu inteiro agrado.

SK Poďakovanie:

Ďakujeme, že ste si vybrali nábytok navrhnutý a vyrobený spoločnosťou Parisot Group. Dúfame, že budete svojim nákupom absolútne spokojní.

AR شكر:

باريزو نشكركم لاختياركم هذه القطعة من الأثاث من تصميم وتنمى أن تنال Parisot وتصنيع مجموعة رضاءكم.

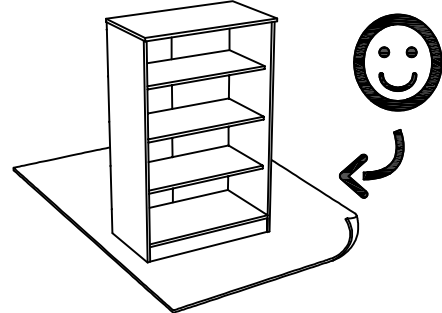
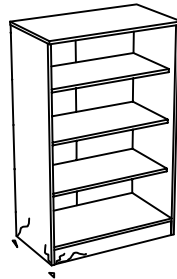
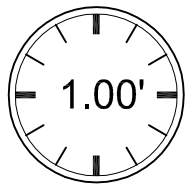
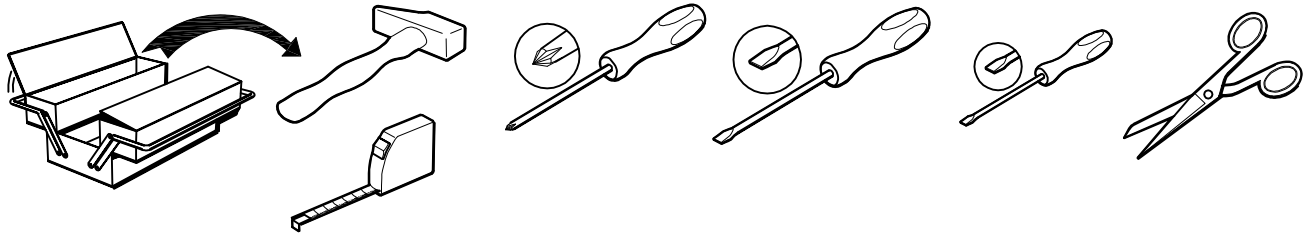

contact@parisot.com

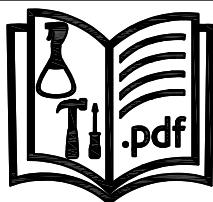

www.parisot.com

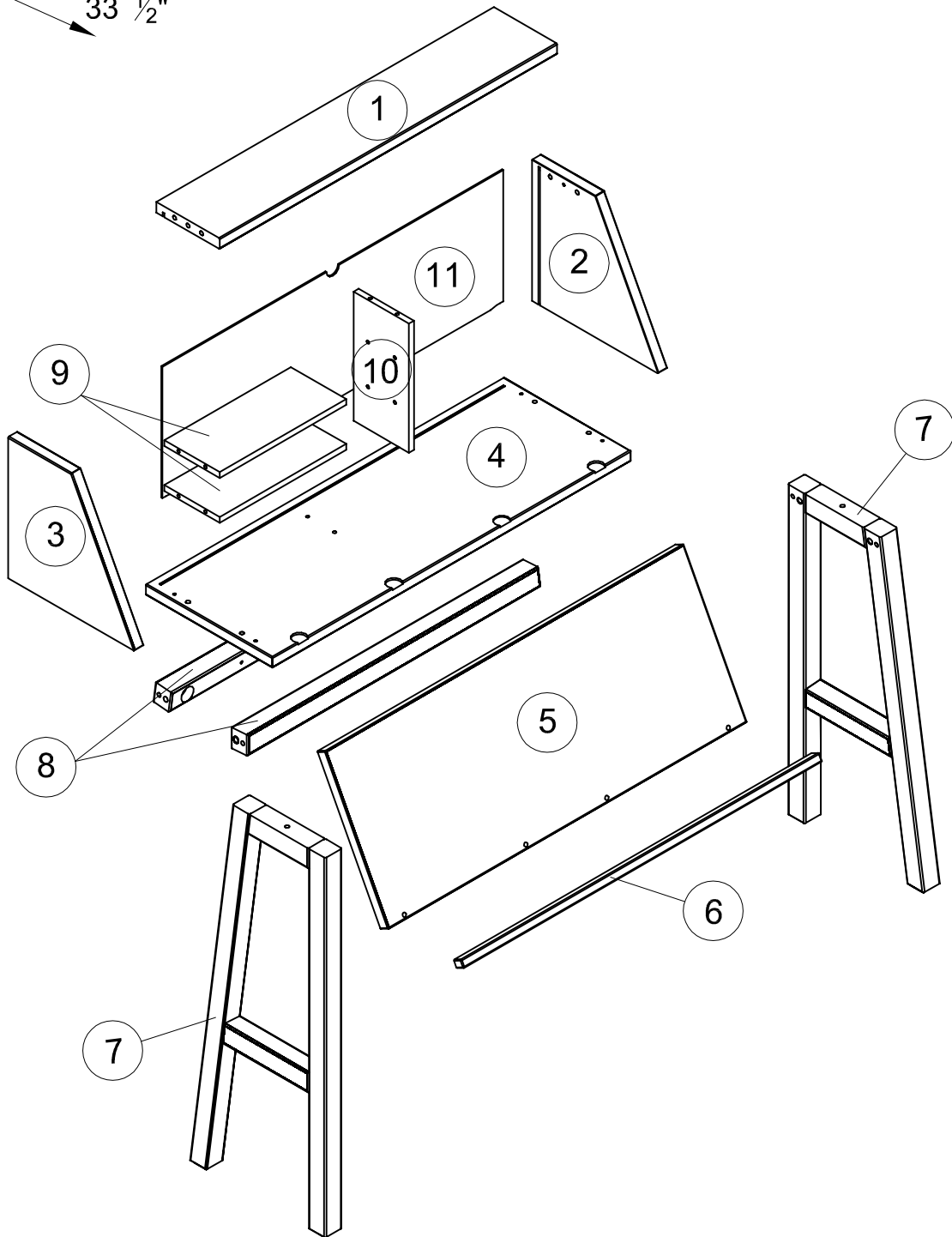
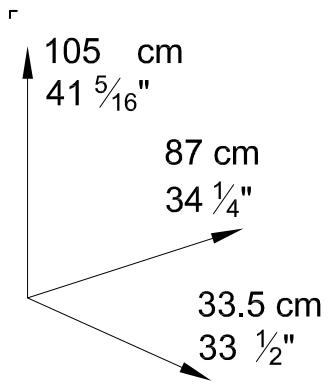



5940BURE

5940BURE			mm			inch		
①	x	1	800	150	22	31 1/2"	5 7/8"	7/8"
②	x	1	299	290	22	11 13/16"	11 7/16"	7/8"
③	x	1	299	290	22	11 13/16"	11 7/16"	7/8"
④	x	1	850	300	22	33 7/16"	11 13/16"	7/8"
⑤	x	1	850	331	22	33 7/16"	13 1/16"	7/8"
⑥	x	1	850	19	16	33 7/16"	3/4"	5/8"
⑦	x	2	734.5	322	40	28 15/16"	12 11/16"	1 9/16"
⑧	x	2	696	40	40	27 3/8"	1 9/16"	1 9/16"
⑨	x	2	300	127	12	11 13/16"	5	1/2"
⑩	x	1	265	129	12	10 7/16"	5 1/16"	1/2"
⑪	x	1	808	272.5	2.5	31 13/16"	10 3/4"	1

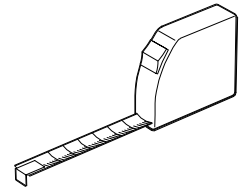

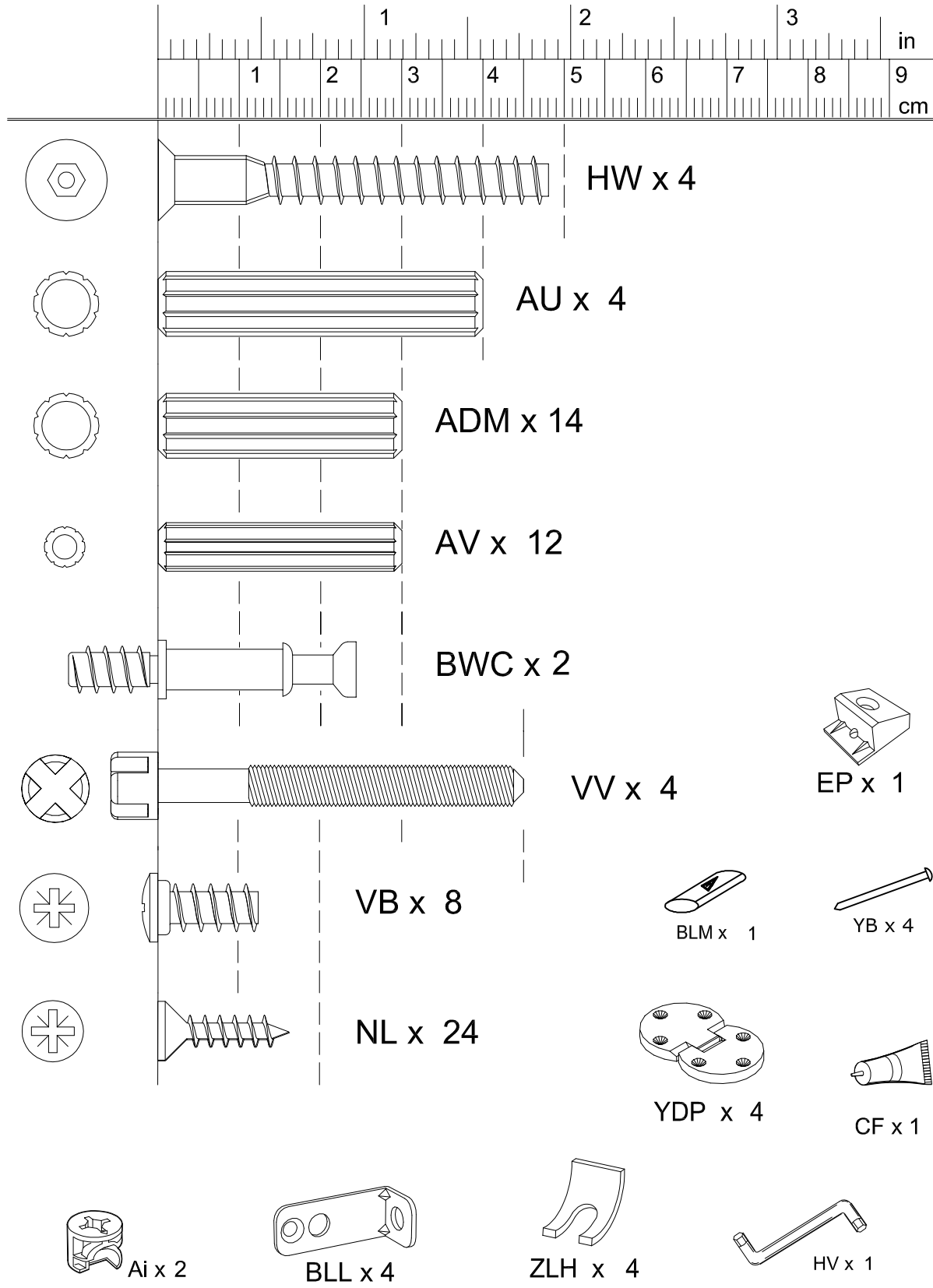

1

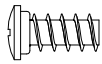

VB x 4

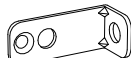

BLL x 4



AU x 4

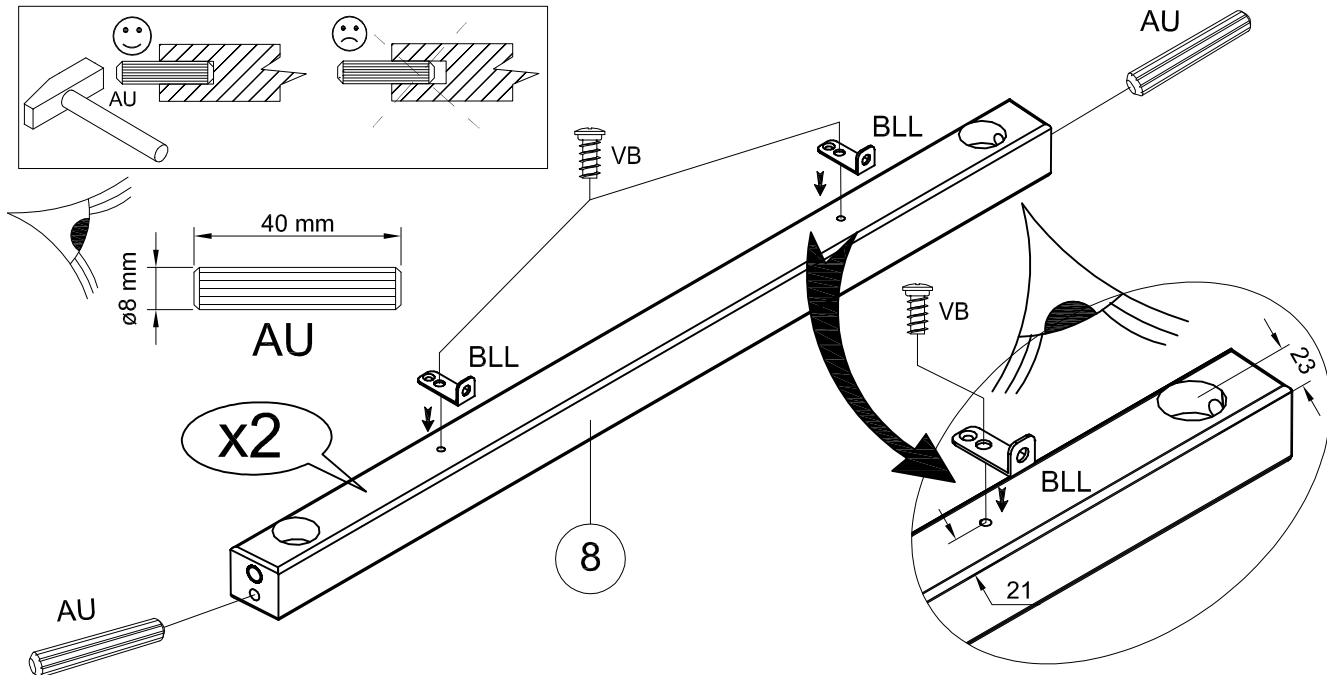
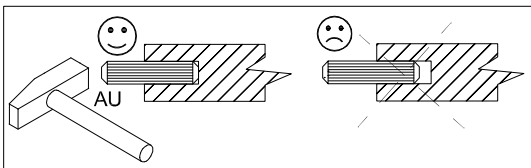

2



ADm x 2

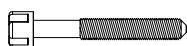

VV x 4

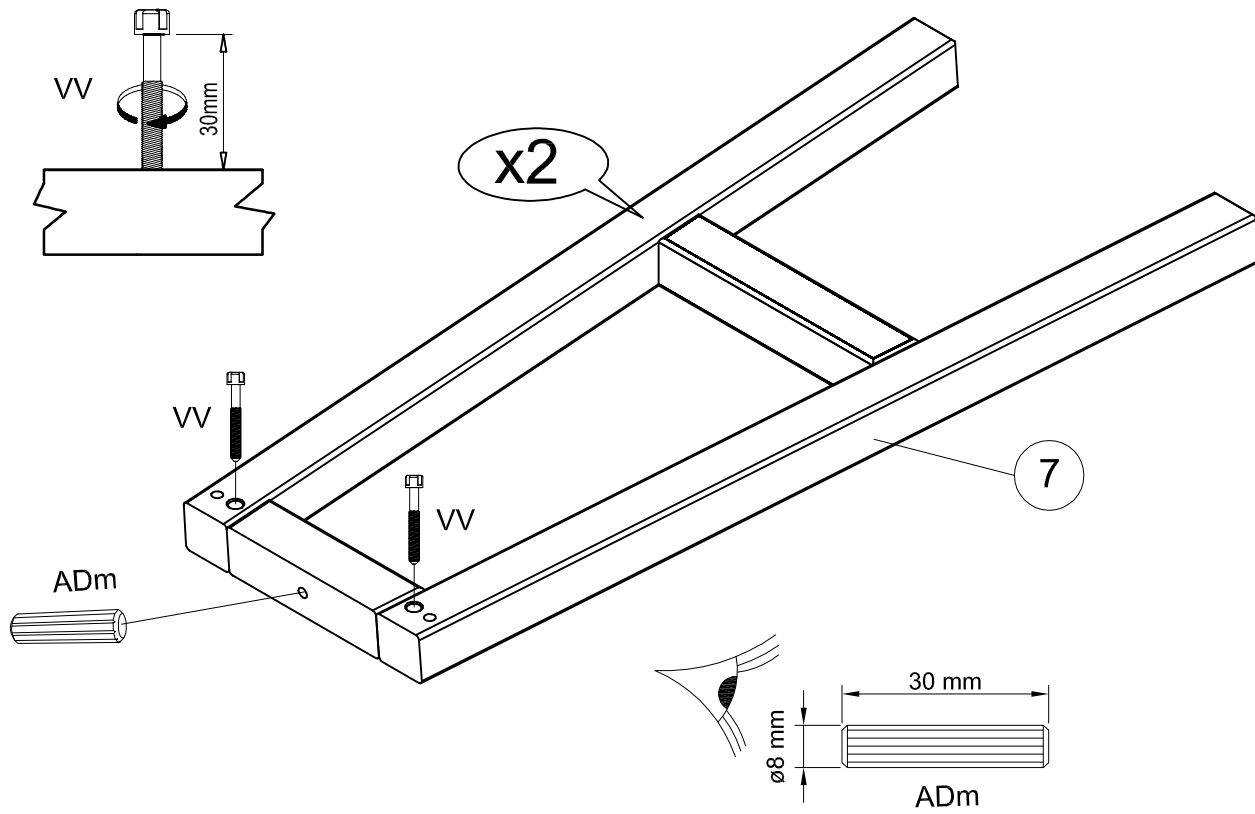
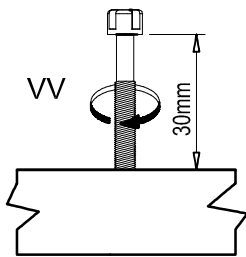

3

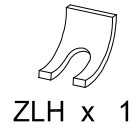

ZLH x 1

N0636_02

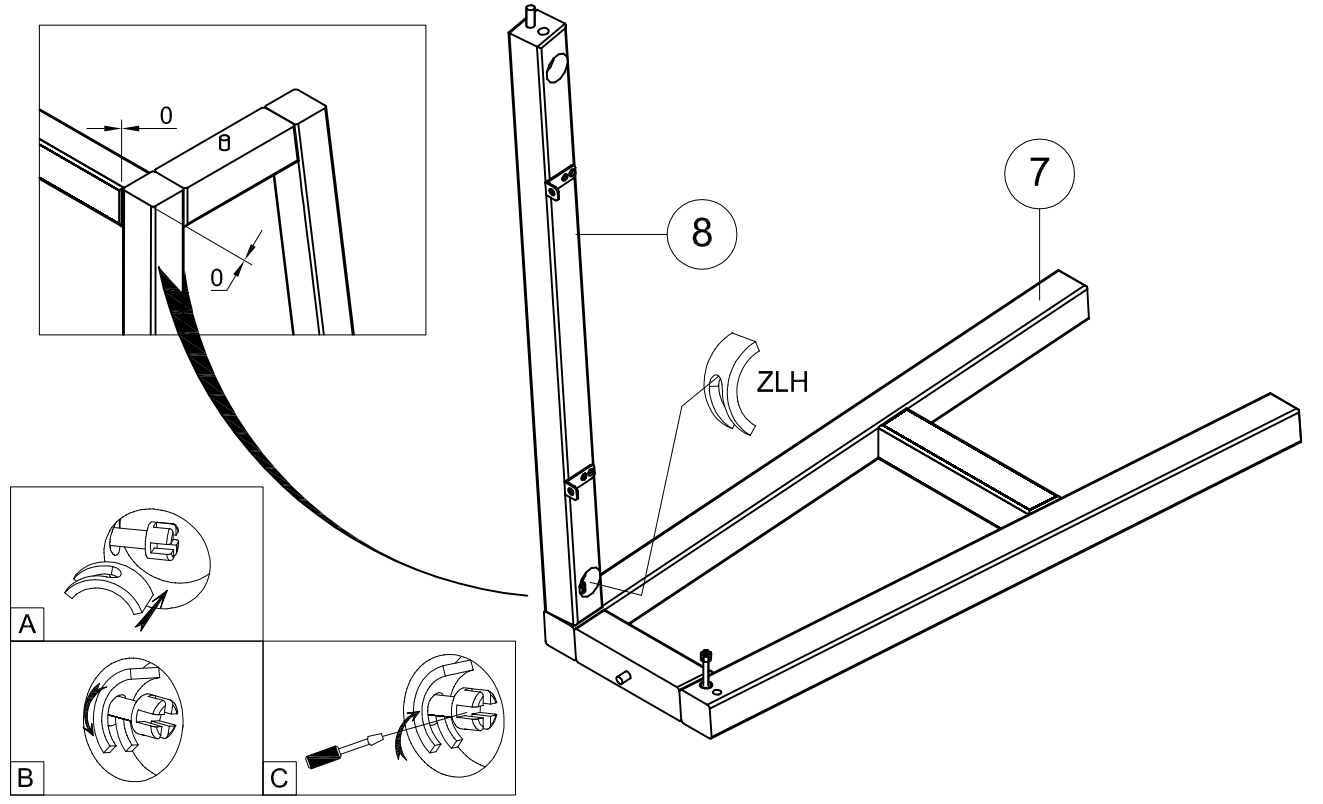

4

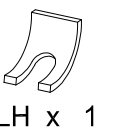

ZLH x 1

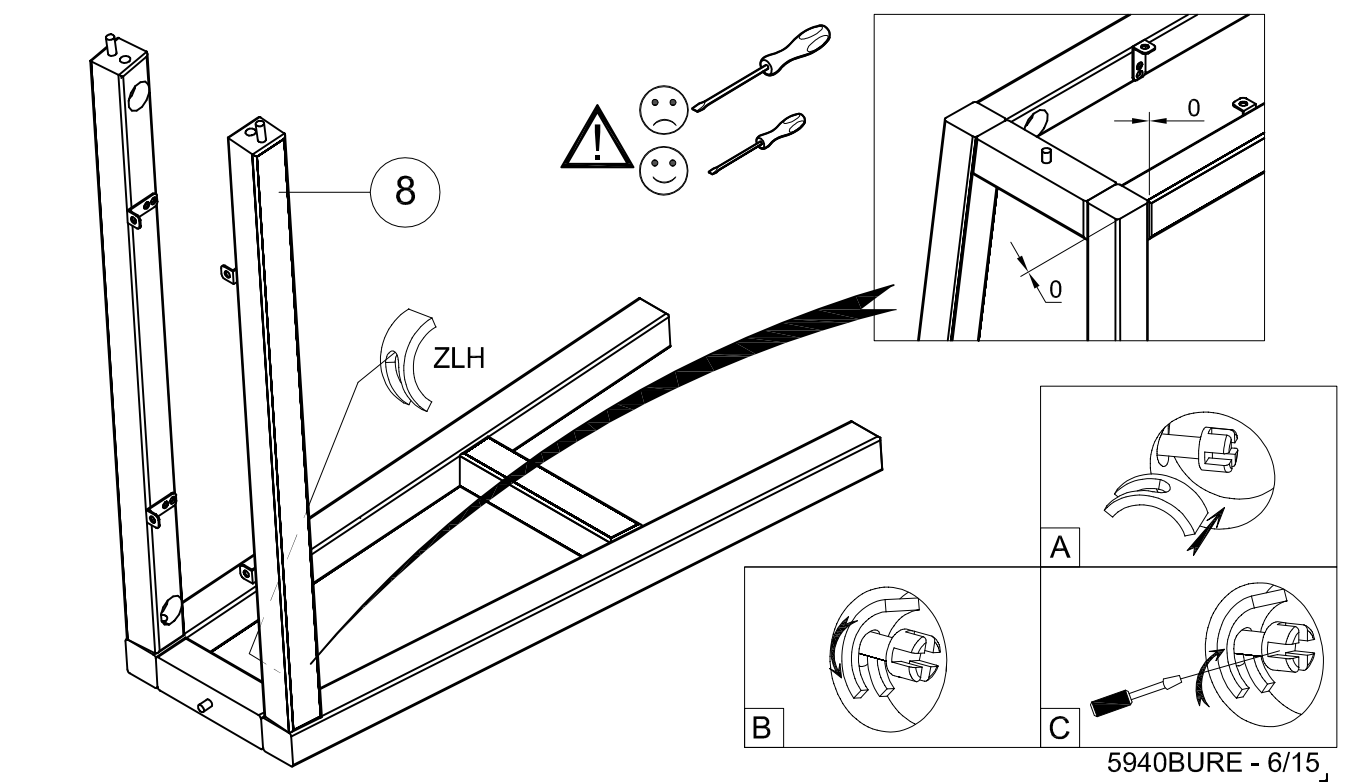

5

ZLH x 2

N0636_02¹

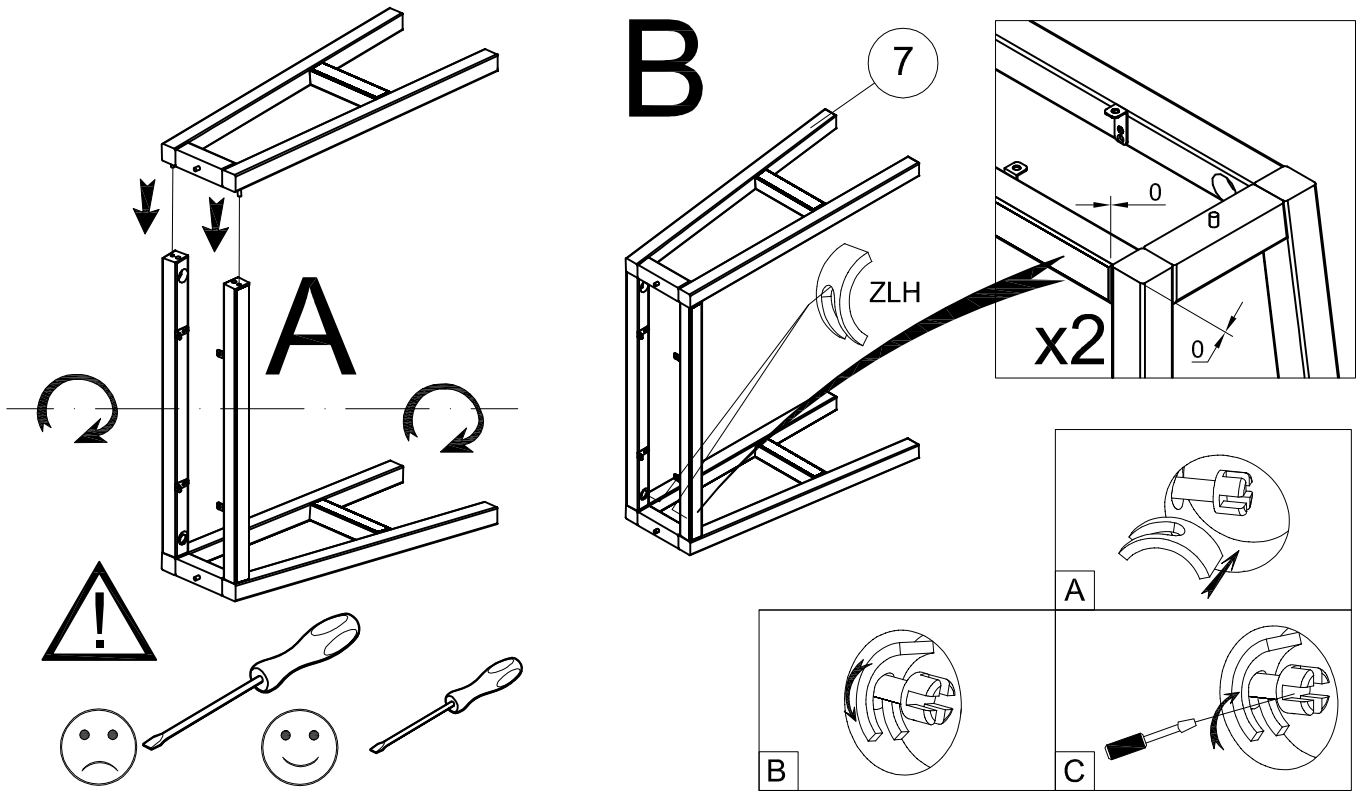

6

AV x 12

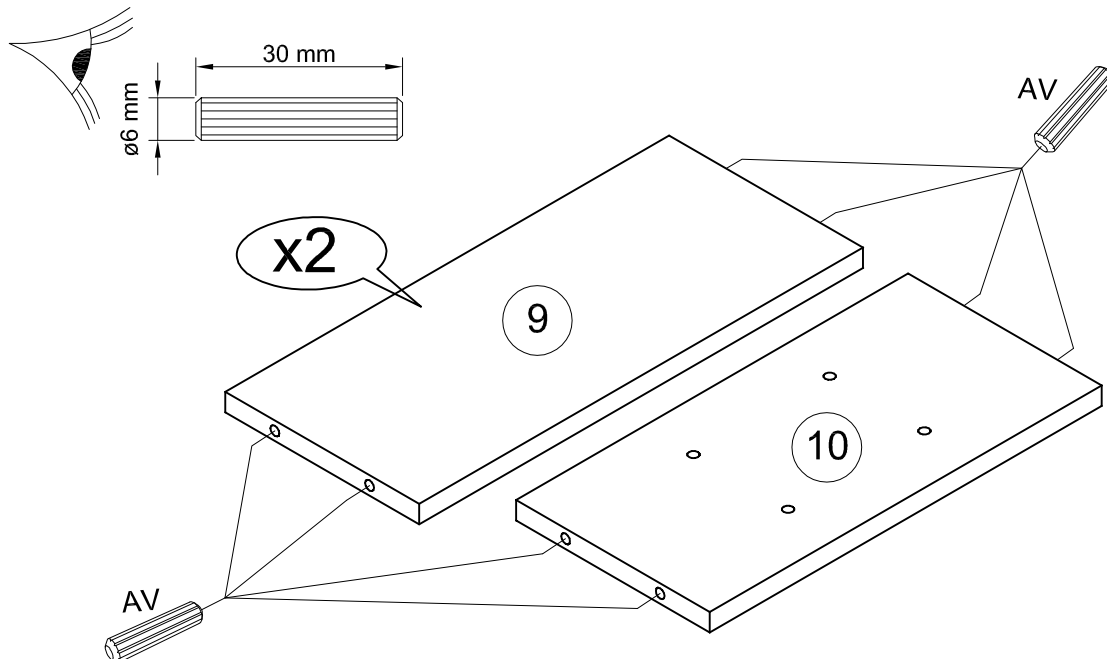

9

N0636_02.

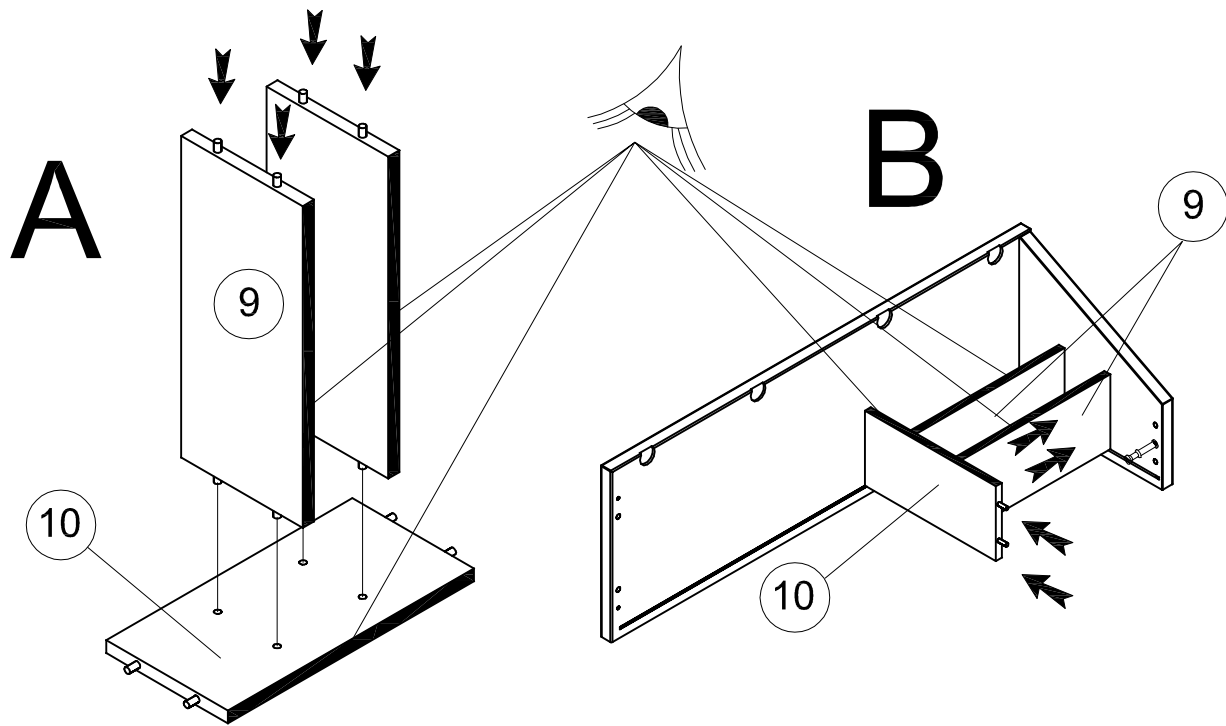

10

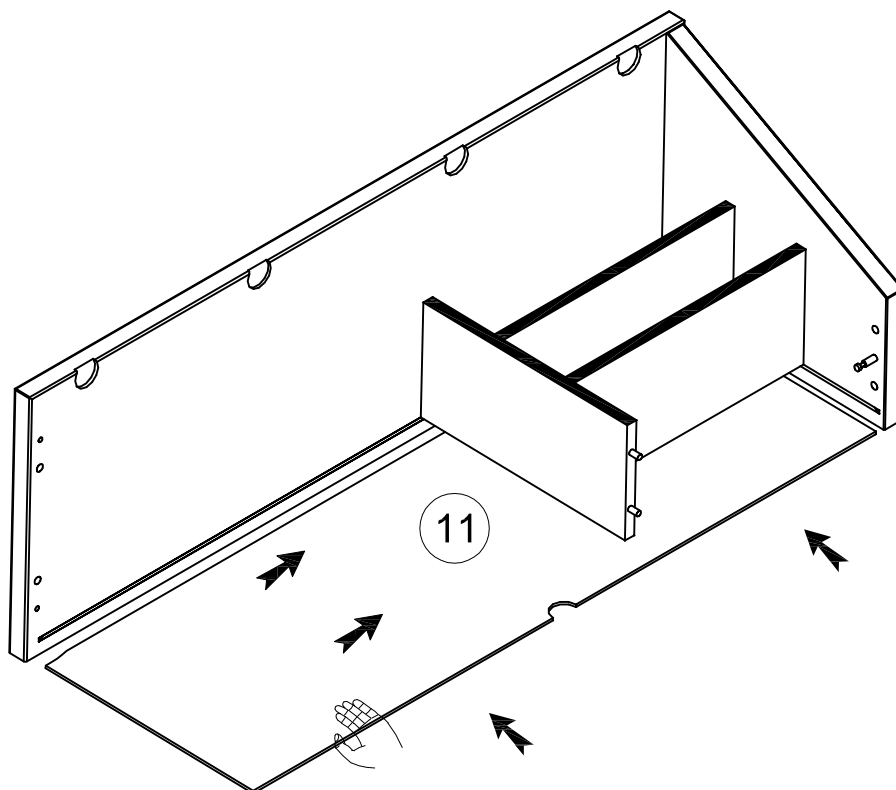

11



Ai x 1

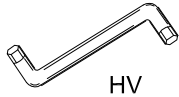

HV

N0636_02

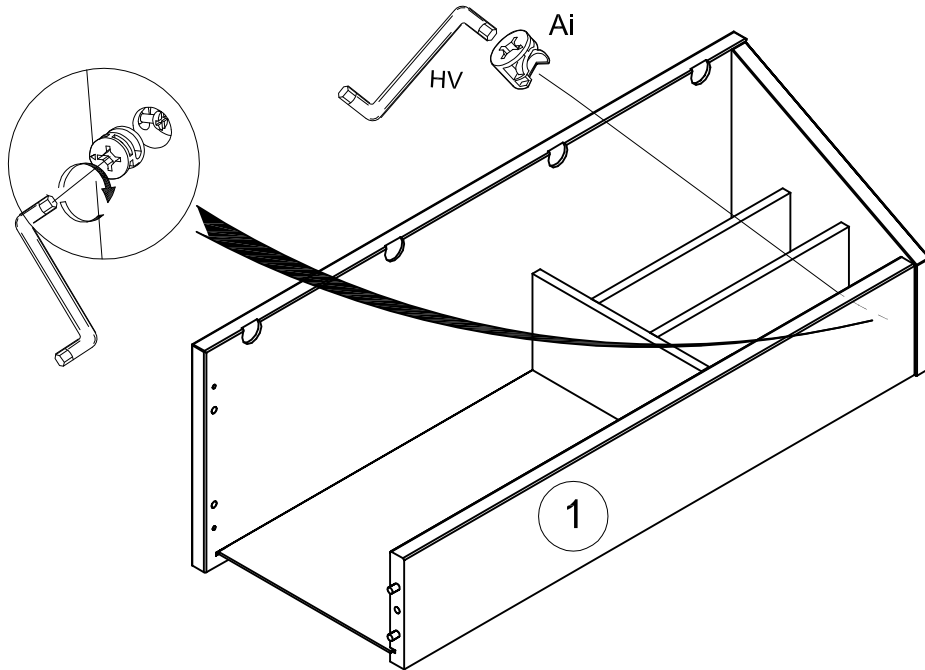

12

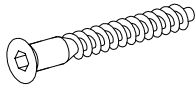

HW x 2



HV



Ai x 1

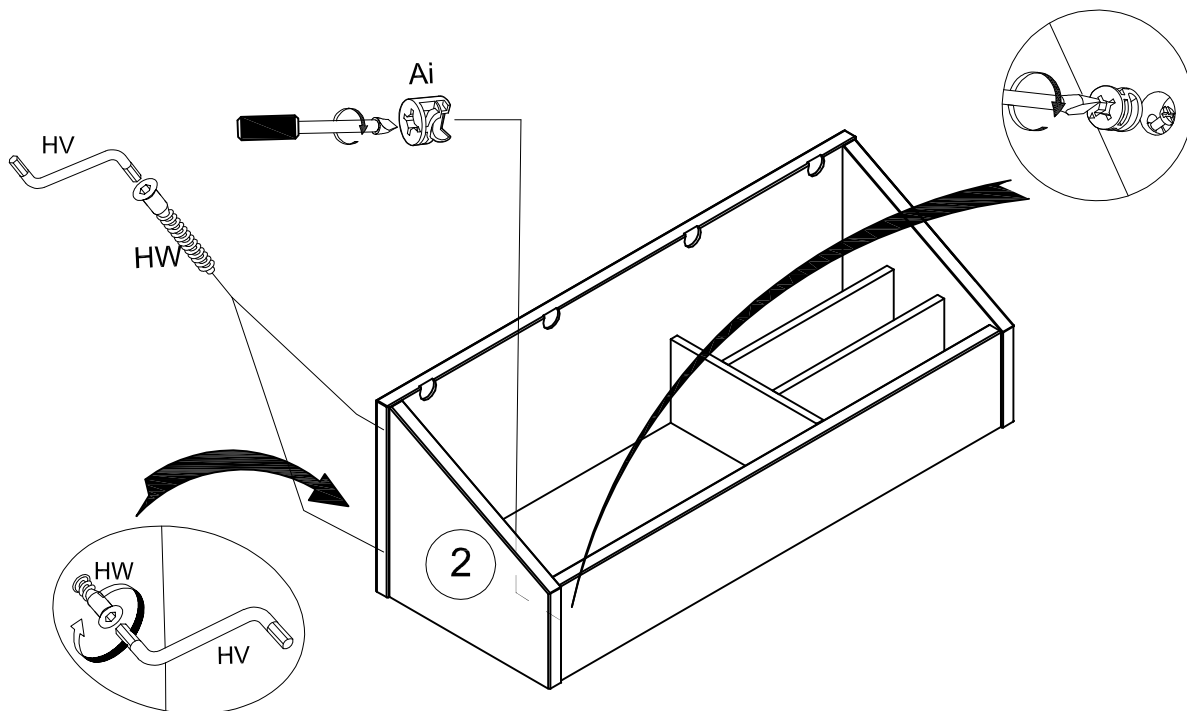

13

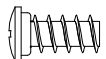

VB x 4

N0636_02

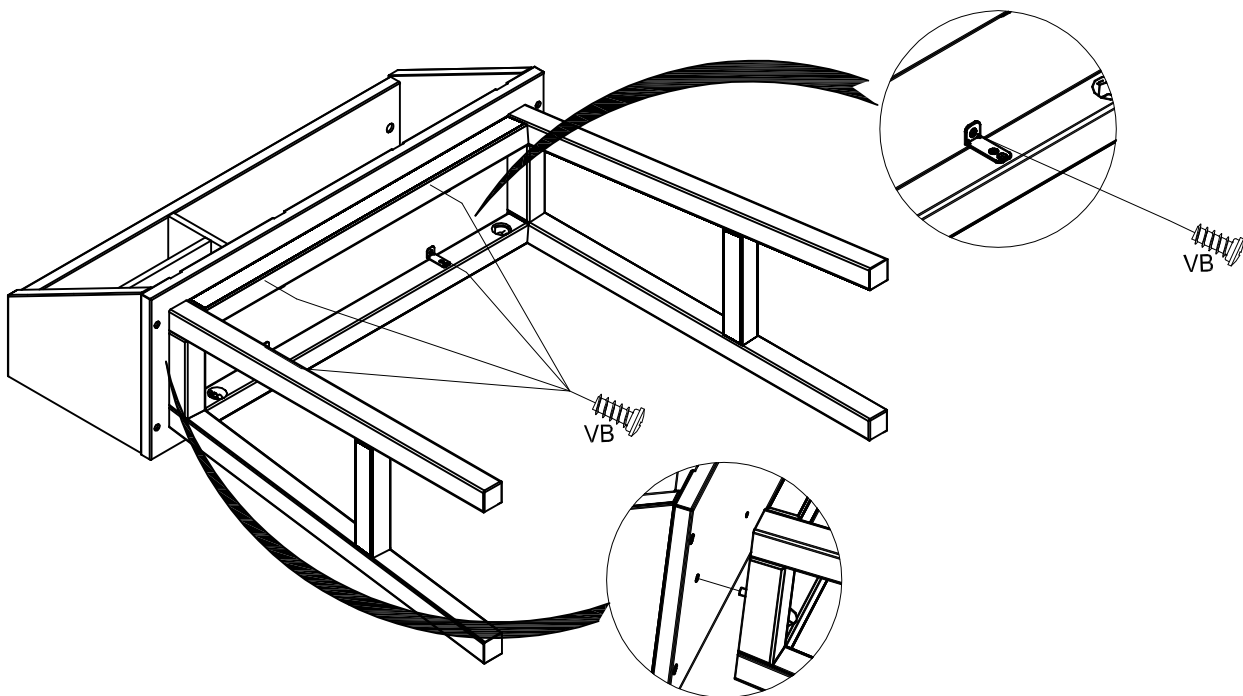

14

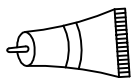

CF

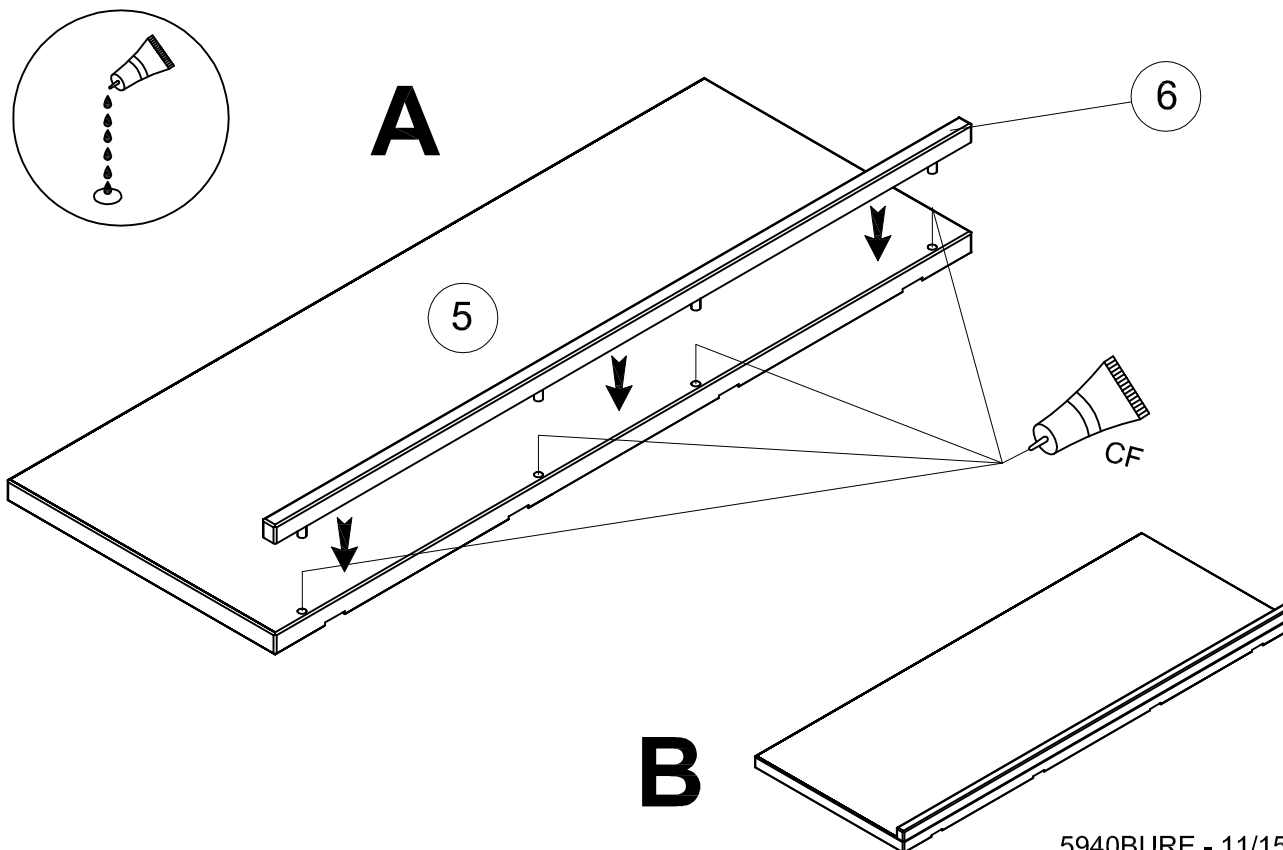

15

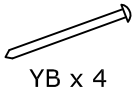

YB x 4

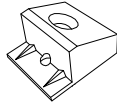

EP x 1

N0636_02

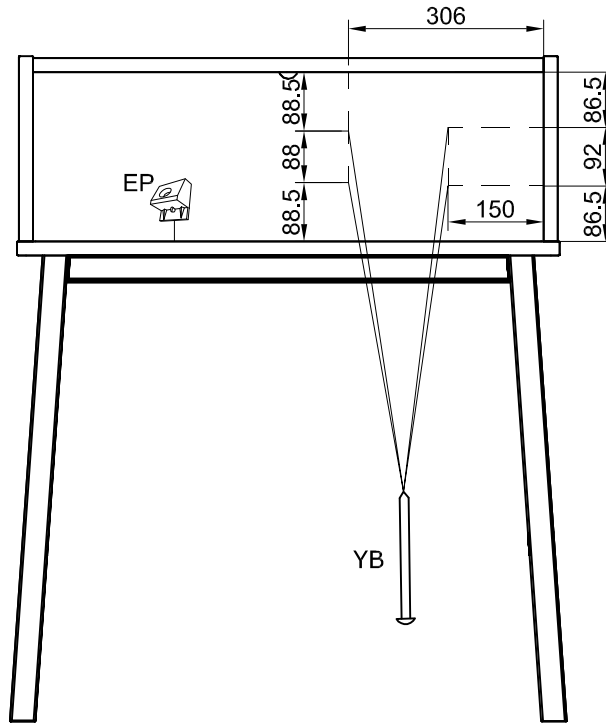

16



NL x 12

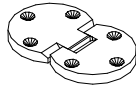

YDP x 4

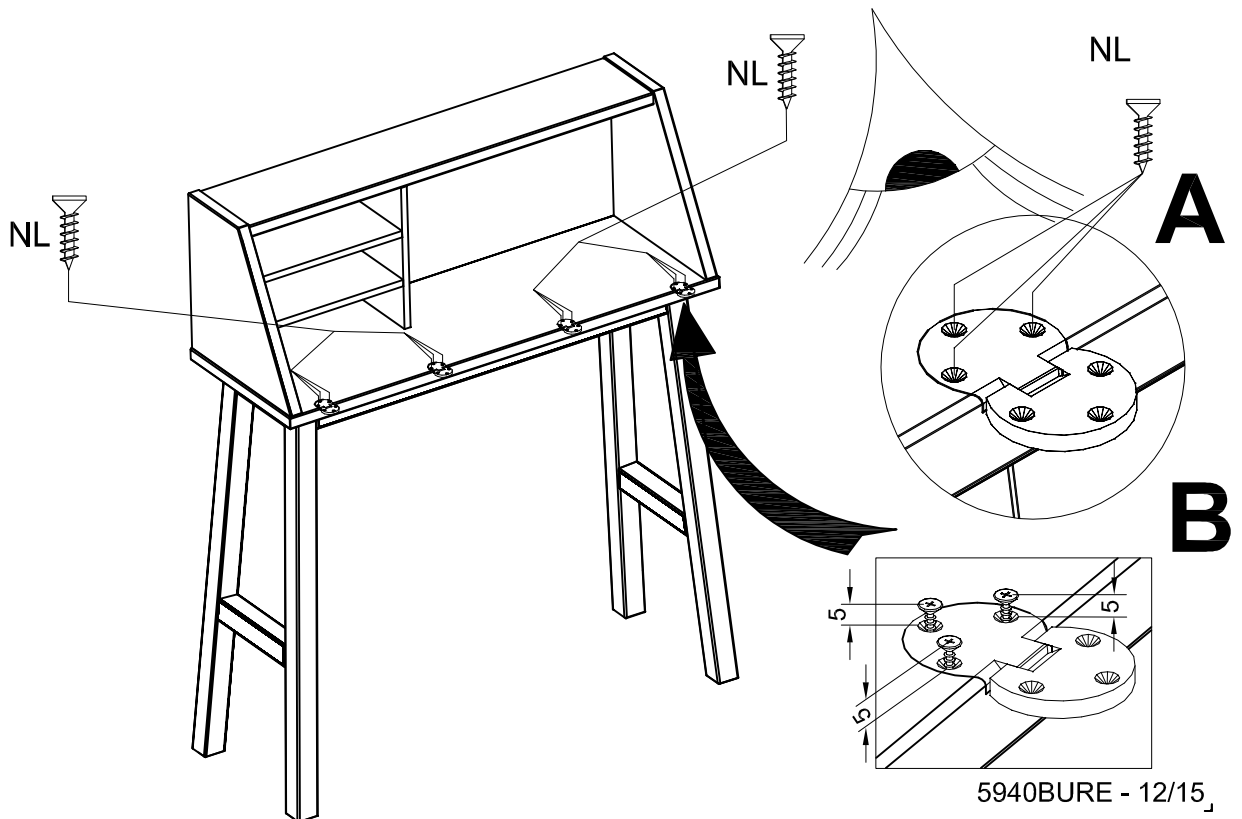

5940BURE - 12/15

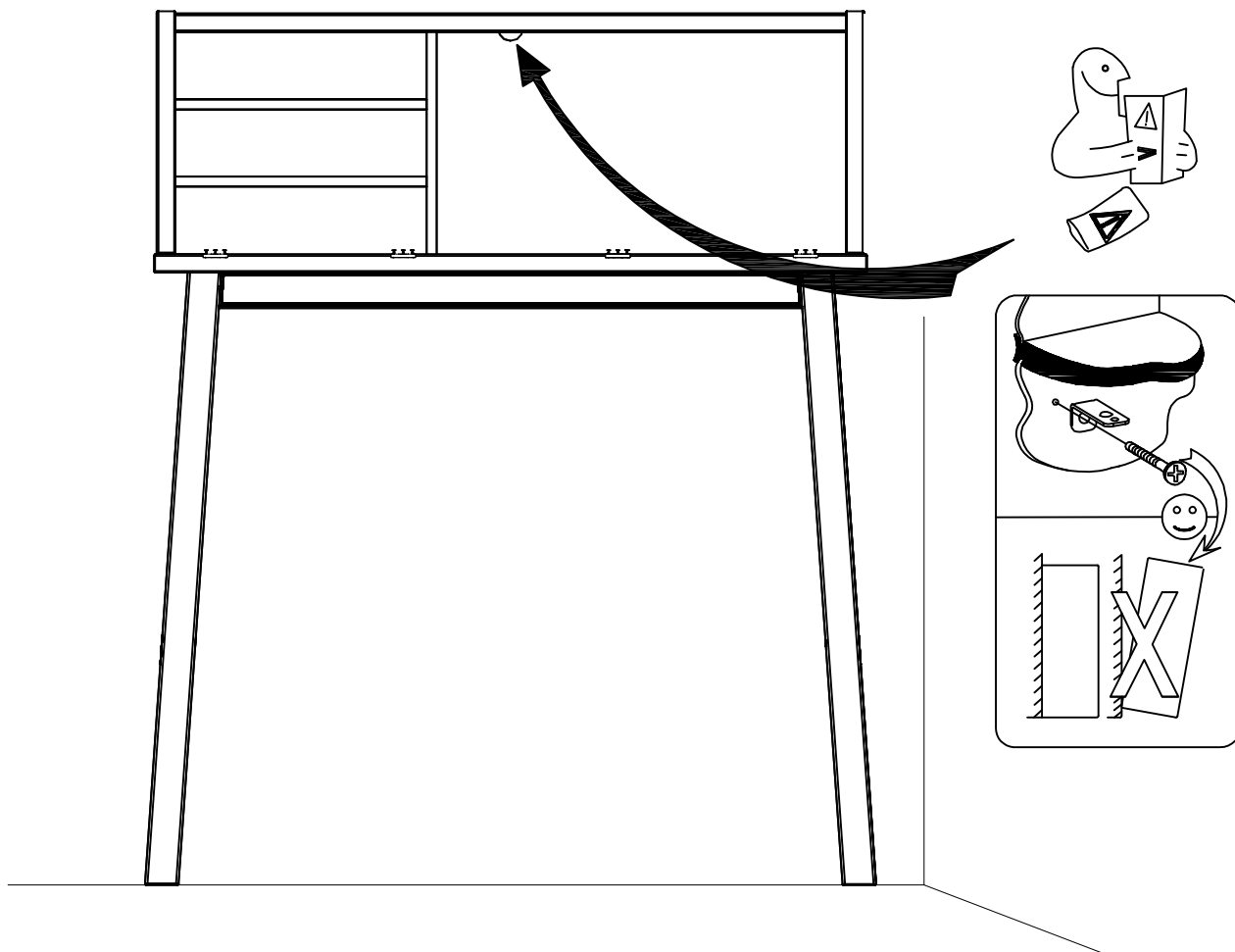
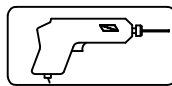

- (FR)** Pour votre sécurité: Fixation du meuble au mur Attention, la fixation doit être réalisée par une personne compétente car cela nécessite des chevilles adaptées à la nature de votre mur.
- (GB)** For your own safety: Attach the furniture to the wall. Important: The furniture must be attached by a qualified person using dowels that are suited to the type of wall.
- (D)** Für Ihre Sicherheit: Befestigung des Möbelstücks an der Wand Achtung, die Befestigung muss von einem Fachmann vorgenommen werden, weil sie an die Wand angepasste Dübel erfordert.
- (E)** Para su seguridad: Fijación del meuble a la pared Ojo! La fijación deberá llevarla a cabo una persona competente ya que necesitará unos tacos adaptados a tipo de pared.
- (PT)** Para a sua segurança: Fixação do móvel na parede. Atenção, a fixação deve efectuada por uma pessoa competente, pois exige a utilização de cavilhas adaptadas à natureza da parede.
- (I)** Per la vostra sicurezza: Fissaggio del mobile alla parete. Nota bene, il fissaggio deve essere eseguito da personale specializzato, poiché l'utilizzo di tasselli adattati alla parete.
- (NL)** Voor uw veiligheid: Bevestiging van het meubel aan de muur. Let op, de bevestiging moet worden uitgevoerd door een bevoegd persoon, want hiervoor zijn pluggen nodig die specifiek geschikt zijn voor de betreffende muur.

18

NL x 12

N0636_02.

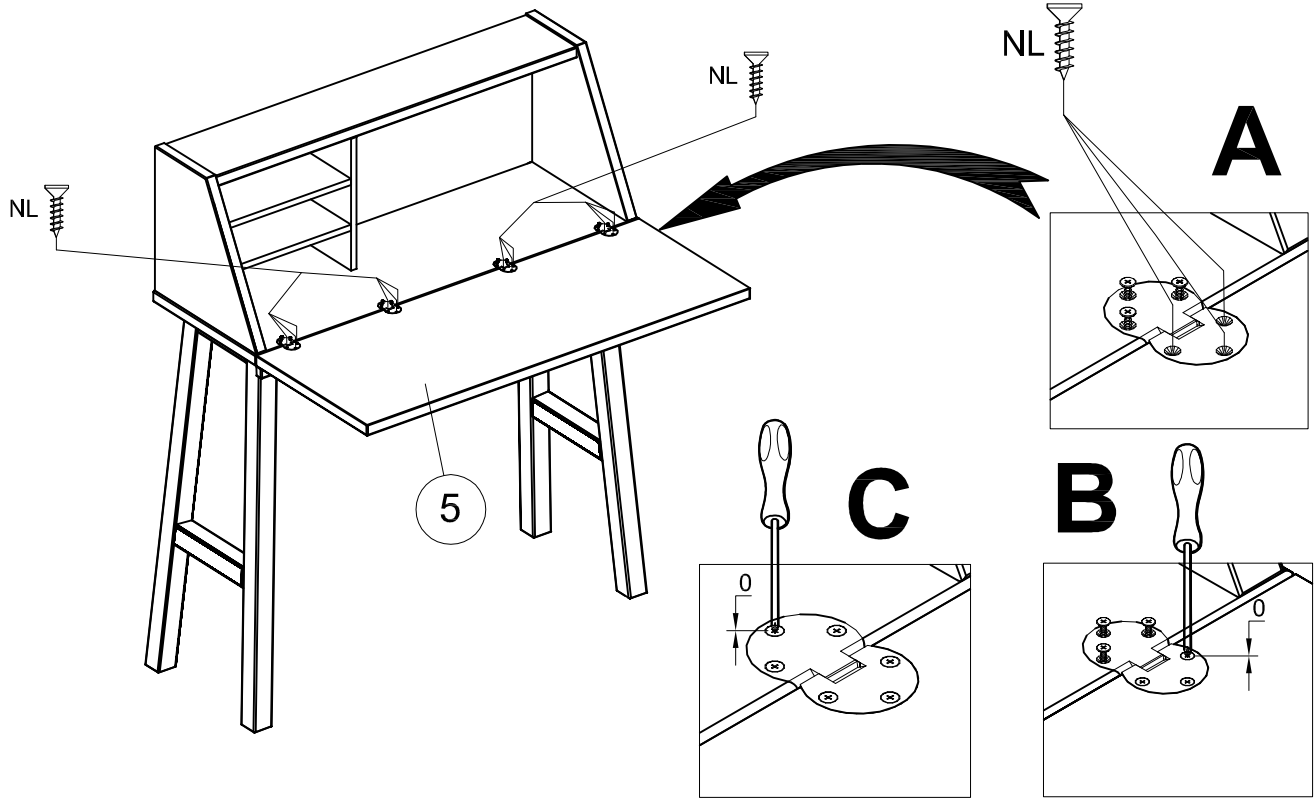

19

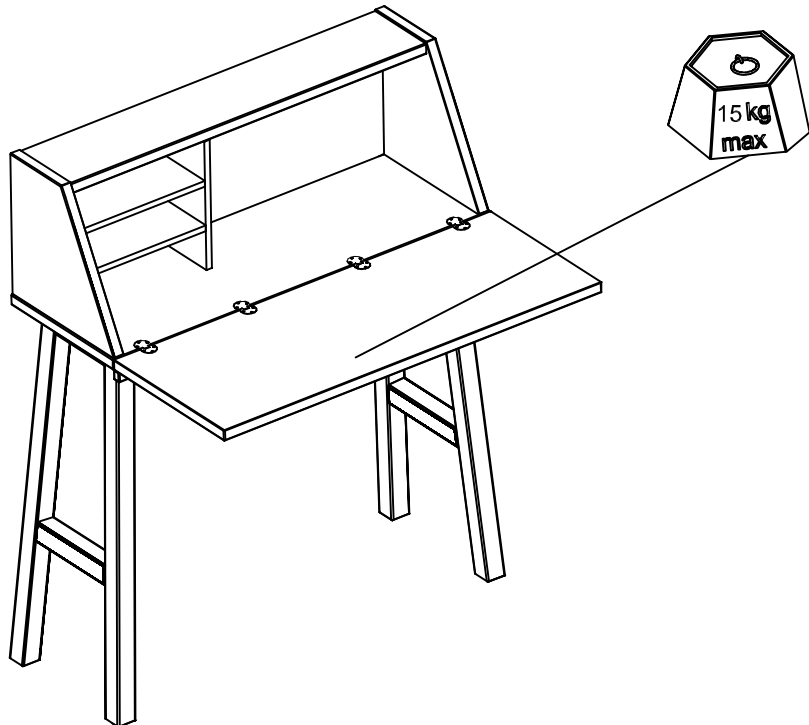

5940BURE - 14/15

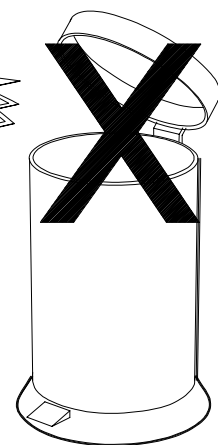
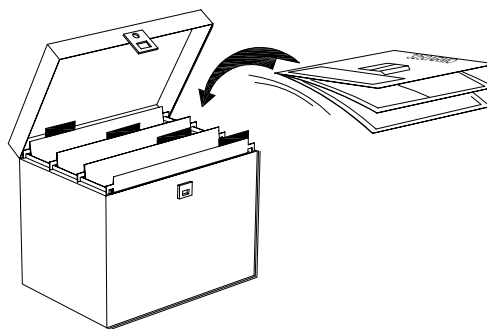
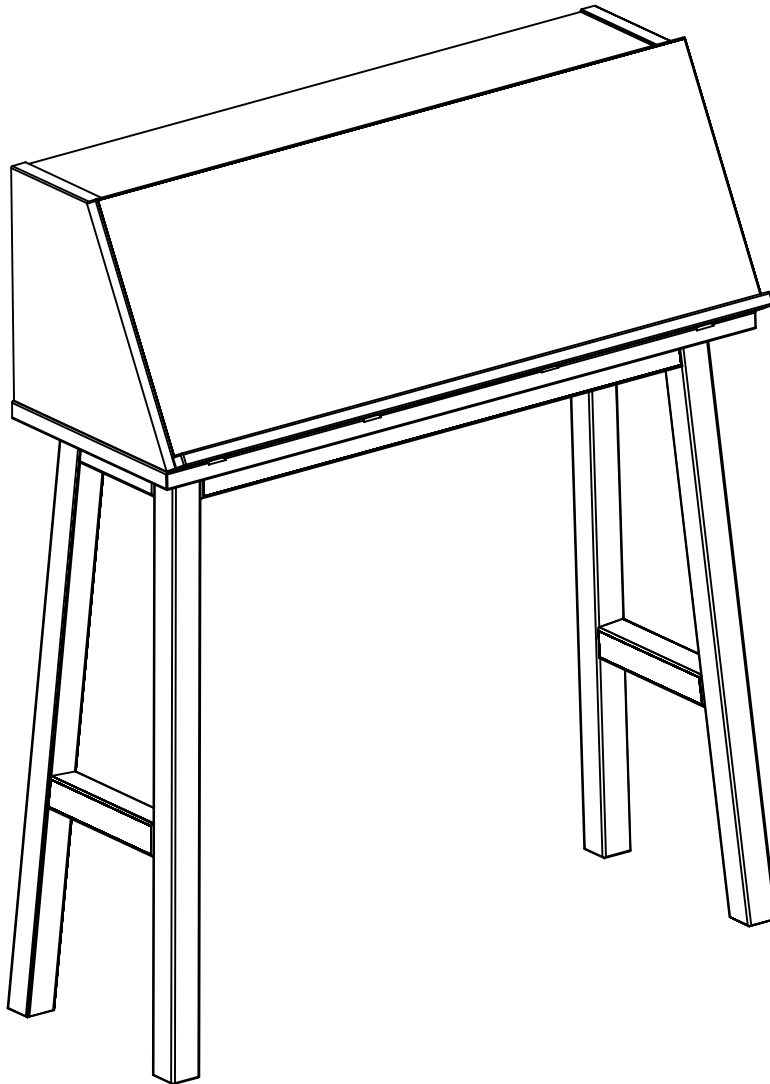

Faites un geste pour l'environnement en triant vos déchets d'emballage
Make a gesture for the environment by sorting out your waste of packaging
Machen Sie eine Bewegung für die Umwelt, ihre Verpackungsabfälle sortierend
Haga un gesto para el medio ambiente escogiendo sus residuos de embalaje